

中華民國102年度
臺北市稅捐統計年報

YEARBOOK OF MUNICIPAL TAX
STATISTICS OF TAIPEI CITY
2013



臺北市稅捐稽徵處
TAIPEI CITY **R**EVENUE **S**ERVICE
103年3月編製

編 製 說 明

- 一、本刊之編製，旨在提供本處稽徵業務執行與成果資料，以為公務計畫、執行、考核及財務管理上之參考。
- 二、本刊資料內容包括稅收概況、稅收統計、稅源及其他、行政組織等 4 大項。
- 三、本刊所稱「年度」係指政府會計年度，採曆年制(當年 1 月 1 日至同年 12 月 31 日)。
- 四、本刊數字因尾數四捨五入，故部分總數與細項之間，或有未能吻合情事，計算時仍以原始數據計算。
- 五、本刊所有符號「—」表示無數值，「--」表示無意義數值，「…」表示數值不明或尚未產生資料，「0」表示有數值而不及半單位，數字前加(-)者表示退稅或減免數，(+)者表示增加數。
- 六、本刊以前各期數字，若與本期有出入者，以本期所列數字為準。

目 次

壹、稅收概況

一、102 年度稅收概況	2
二、近 10 年稅收	3
三、地價稅	4
四、土地增值稅	5
五、房屋稅	6
六、使用牌照稅	7
七、契稅	8
八、印花稅	9
九、娛樂稅	10

貳、稅收統計

表 1 各項稅捐徵績比較	12
表 2 歷年各項稅捐預算數、查定數與實徵數	
(一)總計	14
(二)稅課收入	
1. 合計	16
2. 地價稅	18
3. 土地增值稅	20
4. 房屋稅	22
5. 使用牌照稅	24
6. 契稅	26
7. 印花稅	28
8. 娛樂稅	30

CONTENTS

I. Analysis of Revenues from Taxes

A. Tax Revenues in 2013	2
B. Tax Revenues in Nearly 10 Years.....	3
C. Land Value Tax.....	4
D. Land Value Increment Tax.....	5
E. House Tax.....	6
F. Vehicle License Tax.....	7
G. Deed Tax	8
H. Stamp Tax.....	9
I. Amusement Tax.....	10

II. Tax Revenue Statistics

Table 1. Net Tax Revenues Compare	12
Table 2. Budget Amount, Audited Amount and Actual Collection in Recent Years	
(I) Grand Total.....	14
(II) Revenues from Taxes	
1. Total	16
2. Land Value Tax	18
3. Land Value Increment Tax	20
4. House Tax	22
5. Vehicle License Tax	24
6. Deed Tax	26
7. Stamp Tax	28
8. Amusement Tax	30

9. 九年國民義務教育附徵教育經費

(1)小計	32
(2)房屋稅	34
(3)娛樂稅	36
(三)工程受益費	38
(四)罰鍰收入	40
(五)規費收入	42
表 3 各項稅捐納庫數	
(一)歷年別	44
(二)稅目別	46
表 4 歷年各項稅捐實徵淨額及指數	48
表 5 本處各項稅捐稽徵成本	52

參、稅源及其他

表 6 地價稅稅源	54
表 7 土地增值稅稅源	56
表 8 房屋稅稅源	58
表 9 使用牌照稅稅源	62
表 10 契稅稅源	64
表 11 印花稅稅源	66
表 12 娛樂稅稅源	68
表 13 違章漏稅案件處理及財務罰鍰執行情形表	72
表 14 各項稅捐滯納案件移送執行情形	76
表 15 查(核)定開徵數及未徵數情形	78

9. Education Surtax	
(1) Subtotal	32
(2) House Tax.....	34
(3) Amusement Tax.....	36
(III) Construction Benefit Fee.....	38
(IV) Punitive Fine Revenue.....	40
(V) Fees Revenue.....	42
Table 3. Taxation Forwarded to Treasury	
(I) Fiscal Year	44
(II) Item of Tax	46
Table 4. Net Amount Remitted and Index in Recent Years	48
Table 5. Cost of Tax Levying	52

III. Tax Sources and Others

Table 6. Sources of Land Value Tax.....	54
Table 7. Sources of Land Value Increment Tax.....	56
Table 8. Sources of House Tax.....	58
Table 9. Sources of Vehicle License Tax.....	62
Table 10. Sources of Deed Tax.....	64
Table 11. Sources of Stamp Tax.....	66
Table 12. Sources of Amusement Tax	68
Table 13. The Management of Cases of Tax Evasion Against Law and Execution Status of Fine	72
Table 14. The Status of Delayed Case Transferred to Execution.....	76
Table 15. The Management of Opening Collection for Assessed(Verified) and of Tax Not Collected	78

表 16 各項稅捐現行稅率表	86
表 17 各項稅捐劃解分配率	93
表 18 本處各項稅捐稽徵工作流程圖	
(一)地價稅	94
(二)土地增值稅	95
(三)房屋稅	96
(四)使用牌照稅	97
(五)契稅	98
(六)印花稅	99
(七)娛樂稅	100
(八)支票退稅	101

肆、行政組織

一、沿革 (附圖)	105
二、組織 (附圖)	107
三、人事 (附圖)	109
表 19 本處人事概況	
(一)法定員額與現有員額	110
(二)年齡與職等、性別	112
(三)學歷及考試	112
(四)年資	113
(五)工作類別	113
表 20 本處歲出預決算數	114

Table 16. Current Tax Rates for Taxation	86
Table 17. The Distribution Rates of Tax	93
Table 18. Work Flow Chart	
(I) Land Value Tax.....	94
(II) Land Value Increment Tax	95
(III) House Tax	96
(IV) Vehicle License Tax	97
(V) Deed Tax	98
(VI) Stamp Tax.....	99
(VII) Amusement Tax.....	100
(VIII) Check Refund.....	101

IV. Administrative Organization

A. The History.....	105
B. Organization	107
C. Personnel	109
Table 19. Personnel Statistic	
(I) Personnel Management & Present Personnel.....	110
(II) By Age & Official Class & Sex	112
(III) By Educational Attainment & Recruitment Way	112
(IV) By Length of Service	113
(V) Work Type.....	113
Table 20. Budget and Closed Account of Expenditures	114

壹、稅收概況

I . Analysis of Revenues from Taxes

一、102 年度稅收概況

102 年度本市地方稅稅收實徵淨額 663.11 億元，較預算數 604.3 億元，超徵 58.81 億元，年度預算達成率 109.7%，除契稅與娛樂稅因不動產交易屬舊屋偏多及臨時性娛樂活動減少等因素影響，分別短徵 0.85 億元及 0.01 億元外，其餘各稅均超徵，其中土地增值稅因土地公告現值調漲及申報件數增加，實徵 189.73 億元，超徵 47.73 億元最多，其次是房屋稅因延續實施高級住宅加價課徵房屋稅、加強稅籍清查及積極清理欠稅，實徵 119.76 億元，超徵 3.76 億元，餘使用牌照稅、印花稅與地價稅，分別超徵 3.5 億元、2.82 億元及 1.86 億元。

102 年度地方稅稅課收入

單位：新臺幣億元

項目 稅目	預算數 (1)	實徵淨額 (2)	超(短)徵		預算達成率 (5)=(2)/(1)*100
			金額 (3)=(2)-(1)	百分比 (4)=(3)/(1)	
稅課收入	604.30	663.11	58.81	9.7%	109.7%
地價稅	219.00	220.86	1.86	0.9%	100.9%
土地增值稅	142.00	189.73	47.73	33.6%	133.6%
房屋稅	116.00	119.76	3.76	3.2%	103.2%
使用牌照稅	66.00	69.50	3.50	5.3%	105.3%
契稅	18.00	17.15	-0.85	-4.7%	95.3%
印花稅	41.00	43.82	2.82	6.9%	106.9%
娛樂稅	2.30	2.29	-0.01	-0.5%	99.5%
教育經費	—	0.00	--	--	--

102 年度各稅比重

實徵淨額總計 663.11 億元

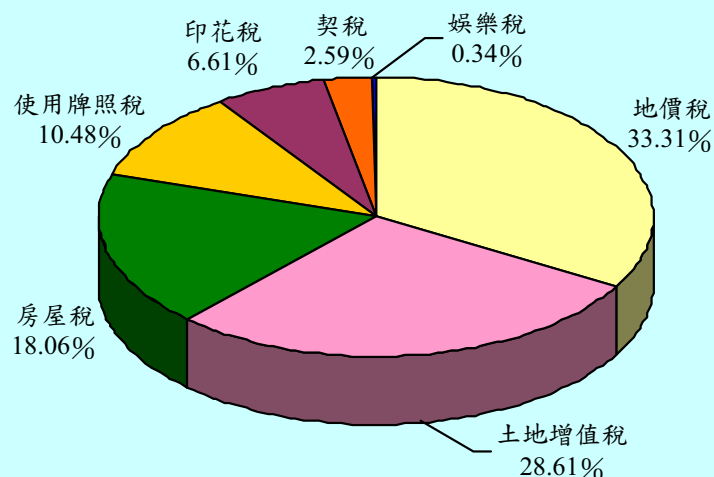

二、近 10 年稅收

近 10 年稅課收入統計表

單位：新臺幣億元

年度別	預算數	實徵淨額	超(短)徵		實徵淨額與上年度增減比較	
			金額	百分比	金額	百分比
93	450.15	578.61	128.46	28.5%	--	--
94	497.93	603.32	105.39	21.2%	24.71	4.3%
95	518.28	593.34	75.06	14.5%	-9.98	-1.7%
96	530.93	616.96	86.03	16.2%	23.62	4.0%
97	540.34	565.71	25.37	4.7%	-51.25	-8.3%
98	535.20	573.45	38.25	7.1%	7.74	1.4%
99	527.10	608.45	81.35	15.4%	35.00	6.1%
100	562.68	619.99	57.31	10.2%	11.54	1.9%
101	610.50	621.89	11.39	1.9%	1.90	0.3%
102	604.30	663.11	58.81	9.7%	41.22	6.6%

近 10 年稅課收入預算數與實徵淨額

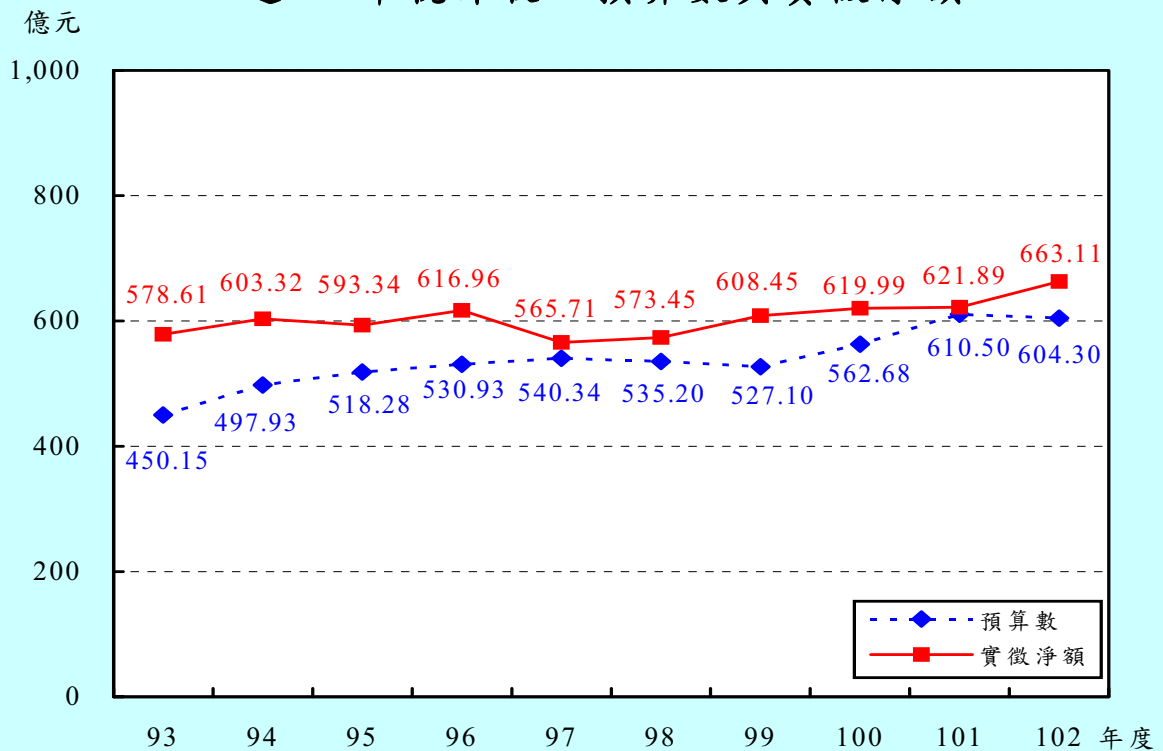

三、地價稅

102 年度實徵淨額 220.86 億元，與預算數 219 億元比較，增加 1.86 億元，超徵 0.9%；較上年度實徵淨額 206.70 億元增加 14.16 億元，成長 6.8%。

因 102 年度重新規定地價及原適用優惠稅率之臨時路外停車場期限屆滿後，按一般用地稅率課徵地價稅，致稅收超徵且較上年度增加。

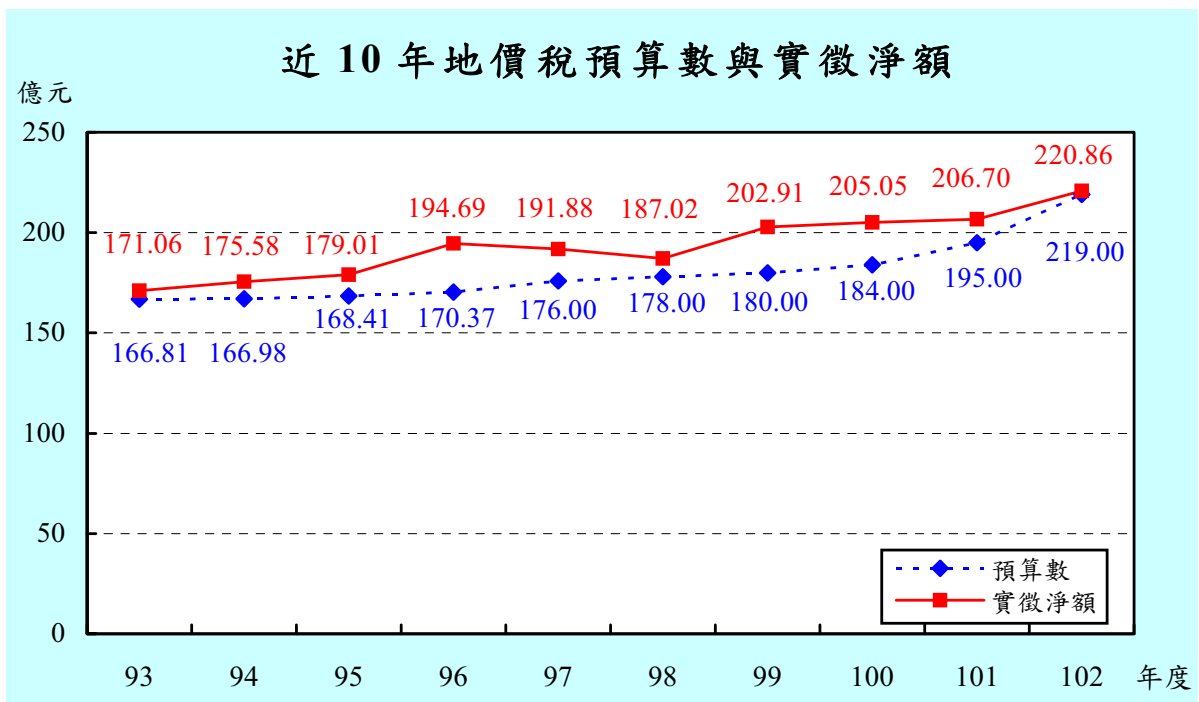

102 年度地價稅稅源比重(土地別面積)

總計 4,951.7003 公頃

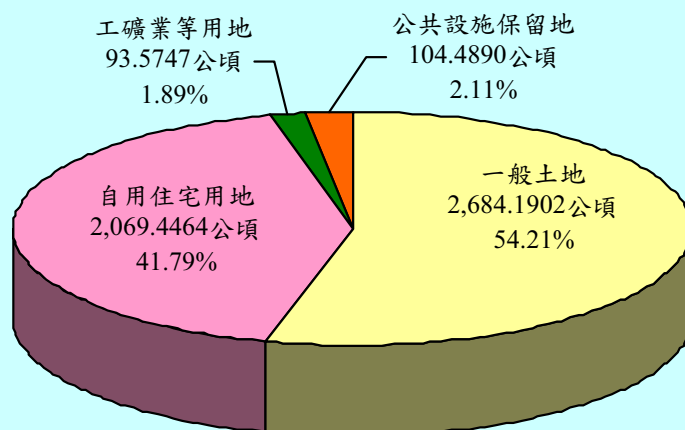

四、土地增值稅

102 年度實徵淨額 189.73 億元，與預算數 142 億元比較，增加 47.73 億元，超徵 33.6%；較上年度實徵淨額 163.97 億元增加 25.76 億元，成長 15.7%。

本年度因公告土地現值平均調漲 9.31% 及申報件數增加，致稅收超徵且較上年度增加。

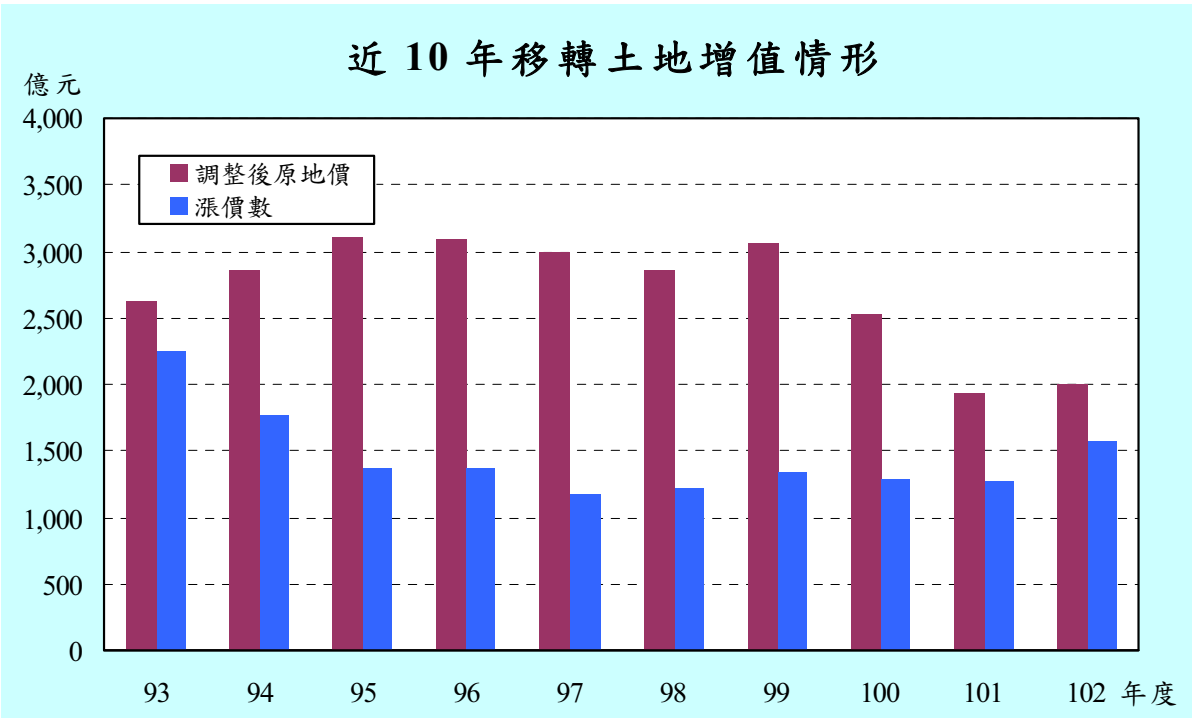
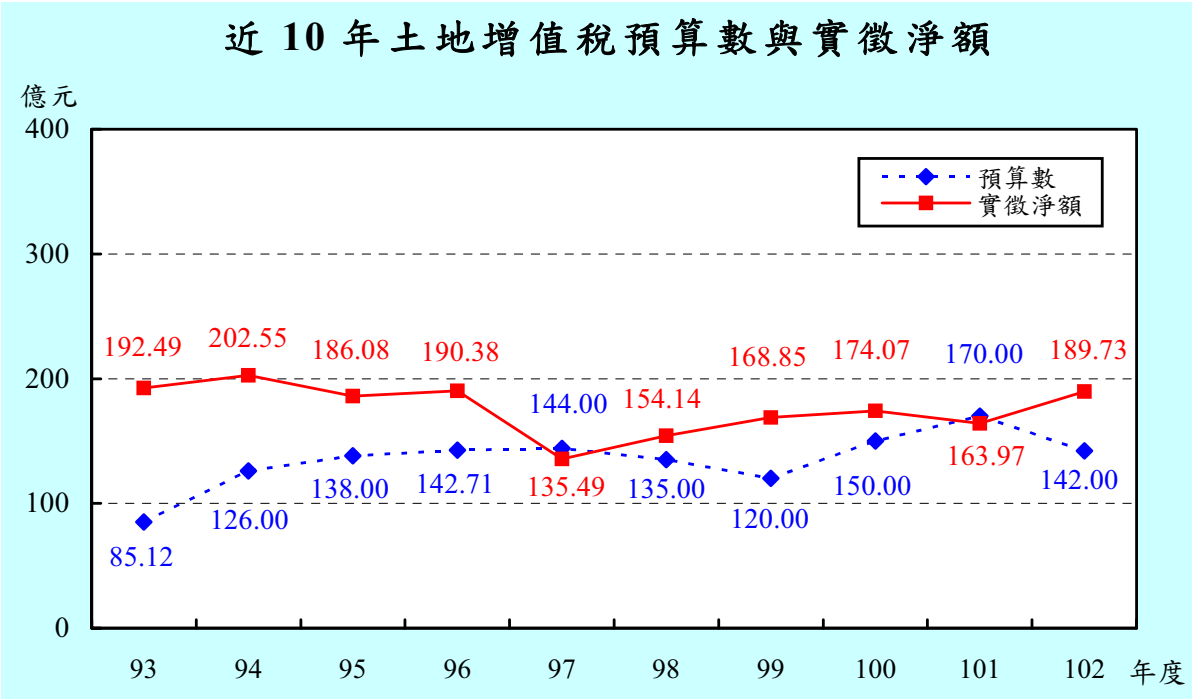

五、房屋稅

102 年度實徵淨額 119.76 億元，與預算數 116 億元比較，增加 3.76 億元，超徵 3.2%；較上年度實徵淨額 118.6 億元增加 1.16 億元，成長 1%。

102 年延續實施高級住宅加價課徵房屋稅政策，以及新建房屋增加、加強房屋稅稅籍清查、積極清理欠稅及提高繳款書送達率，致稅收超徵且較上年度增加。

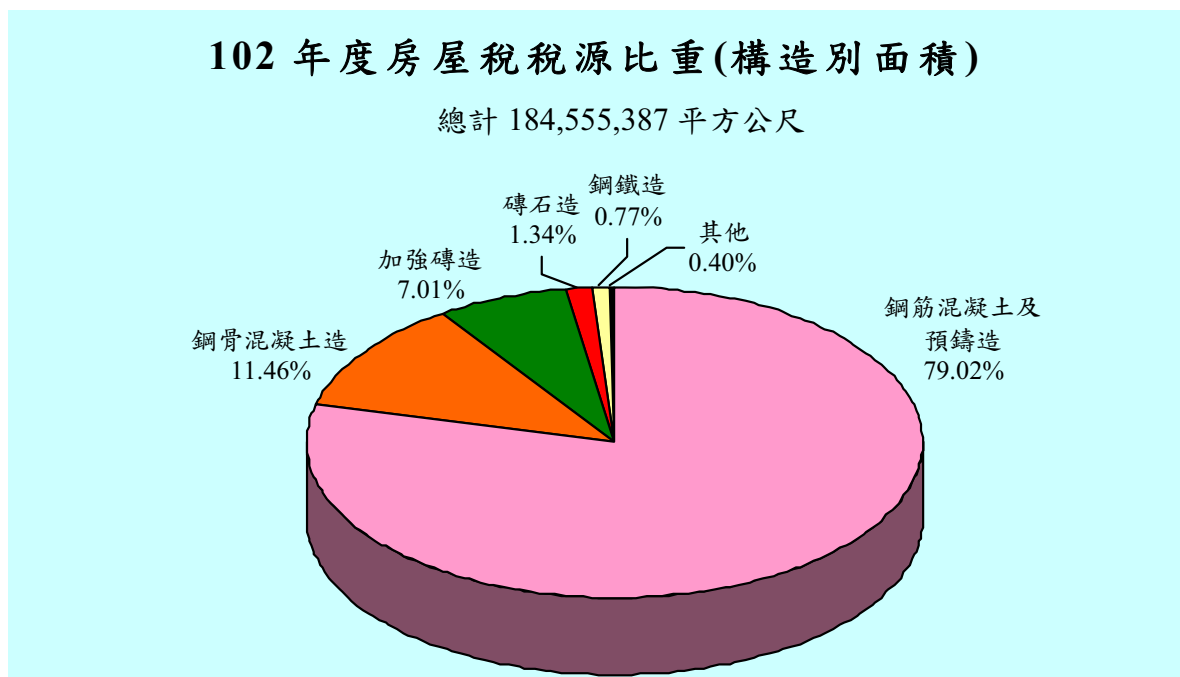
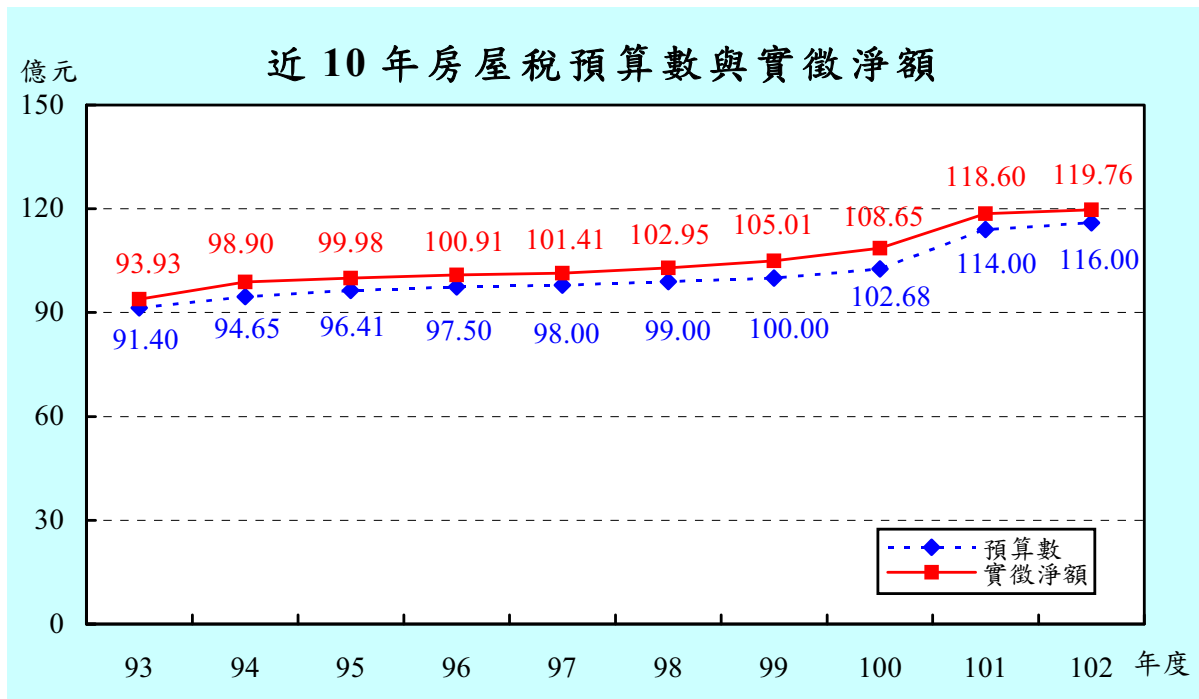

六、使用牌照稅

102 年度實徵淨額 69.5 億元，與預算數 66 億元比較，增加 3.5 億元，超徵 5.3%；較上年度實徵淨額 68.28 億元增加 1.22 億元，成長 1.8%。

102 年度因積極辦理免稅案件清查及欠稅清理，致稅收超徵且較上年度增加。

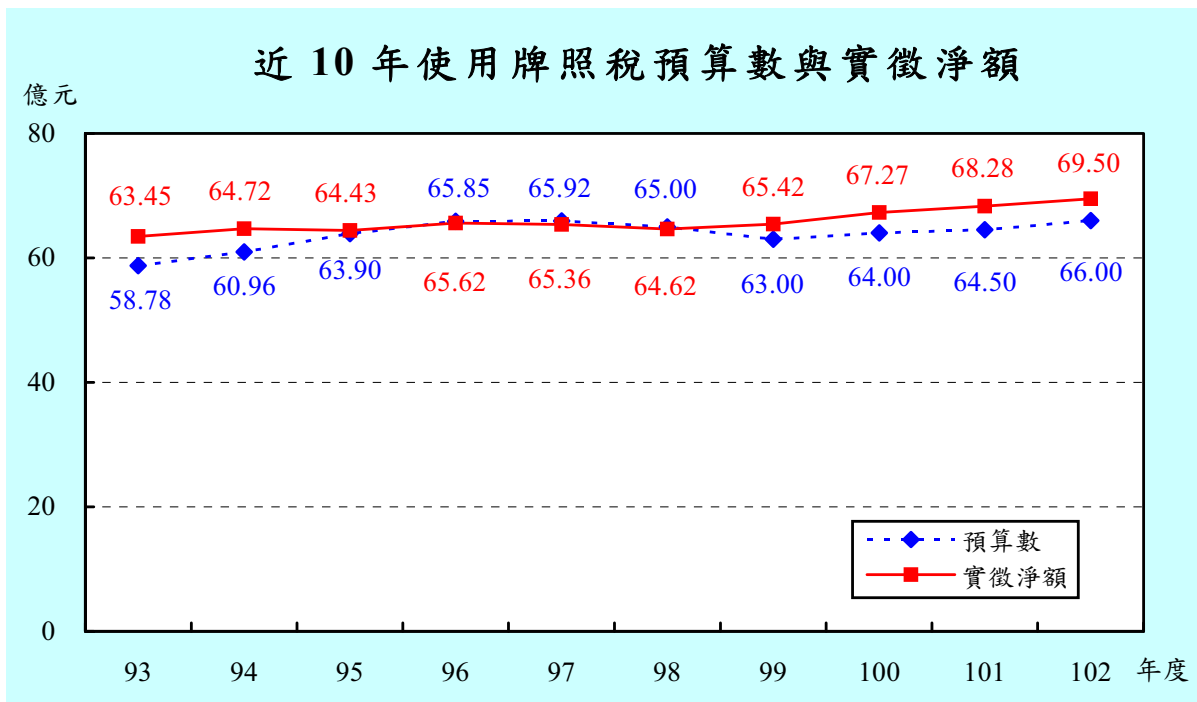

102 年度使用牌照稅稅源比重(車輛別件數)

總計 830,876 件

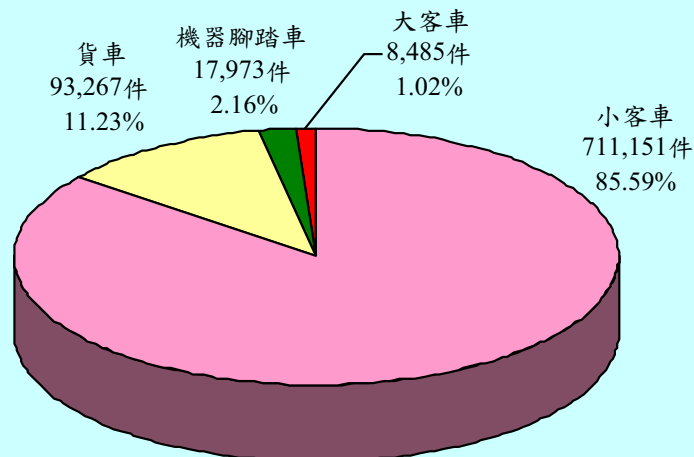

七、契稅

102 年度實徵淨額 17.15 億元，與預算數 18 億元比較，減少 0.85 億元，短徵 4.7%；較上年度實徵淨額 17.31 億元減少 0.16 億元，負成長 0.9%。

102 年契稅稅收因房屋交易市場受特種貨物及勞務稅（奢侈稅）、實價登錄制度影響而使交易量減少，又因移轉房屋大多屬經歷年數 10 年以上之舊屋，其房屋現值偏低，使得契價偏低，致稅收短徵並較上年度減少。

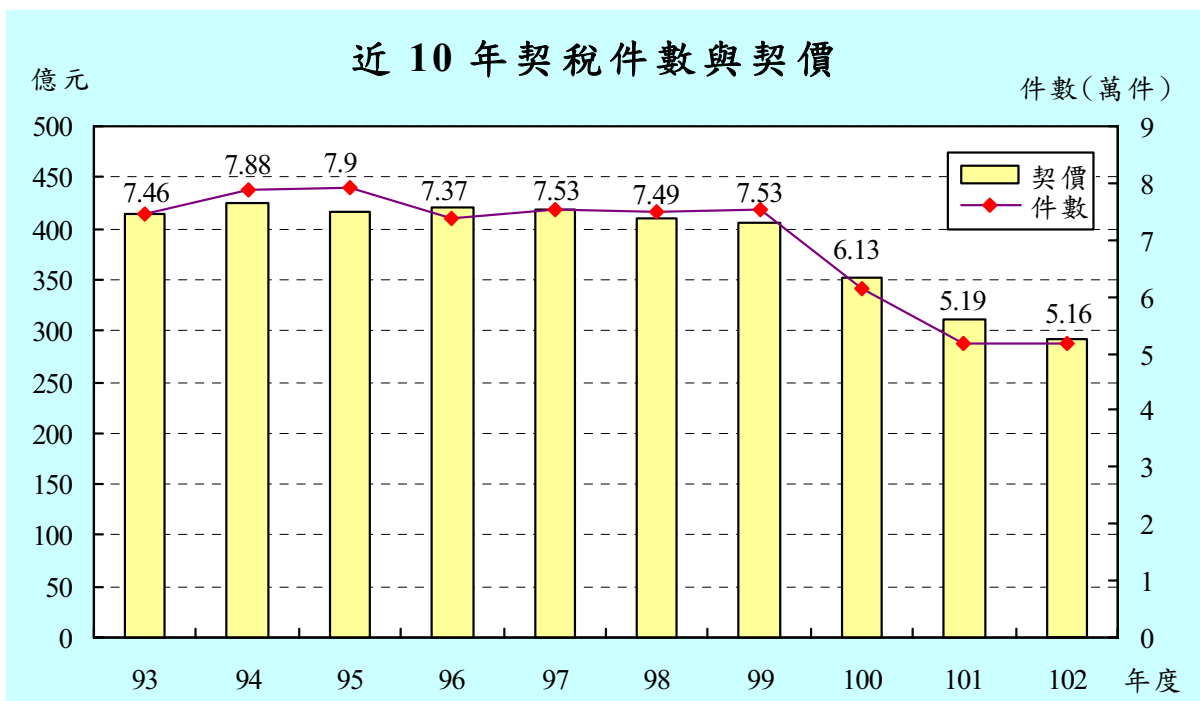
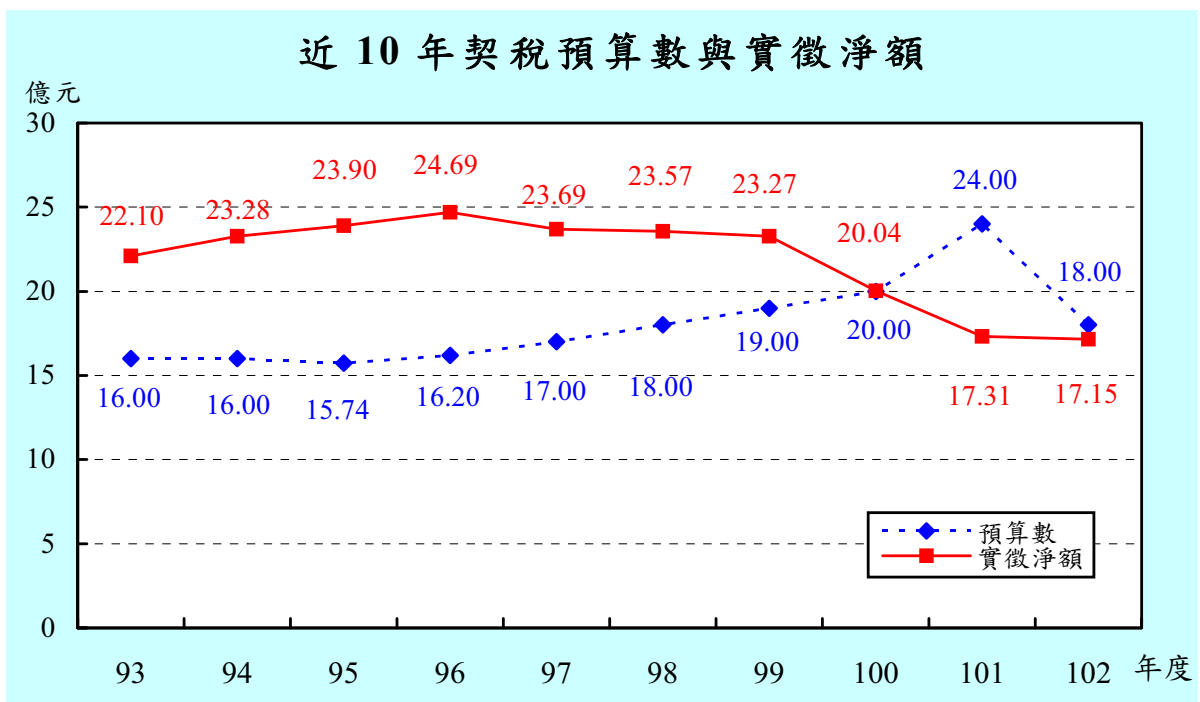

八、印花稅

102 年度實徵淨額 43.82 億元，與預算數 41 億元比較，增加 2.82 億元，超徵 6.9%；較上年度實徵淨額 44.79 億元減少 0.97 億元，負成長 2.2%。

102 年度因執行印花稅應稅憑證檢查作業及積極輔導納稅義務人依法繳納印花稅，致稅收較預算數超徵。

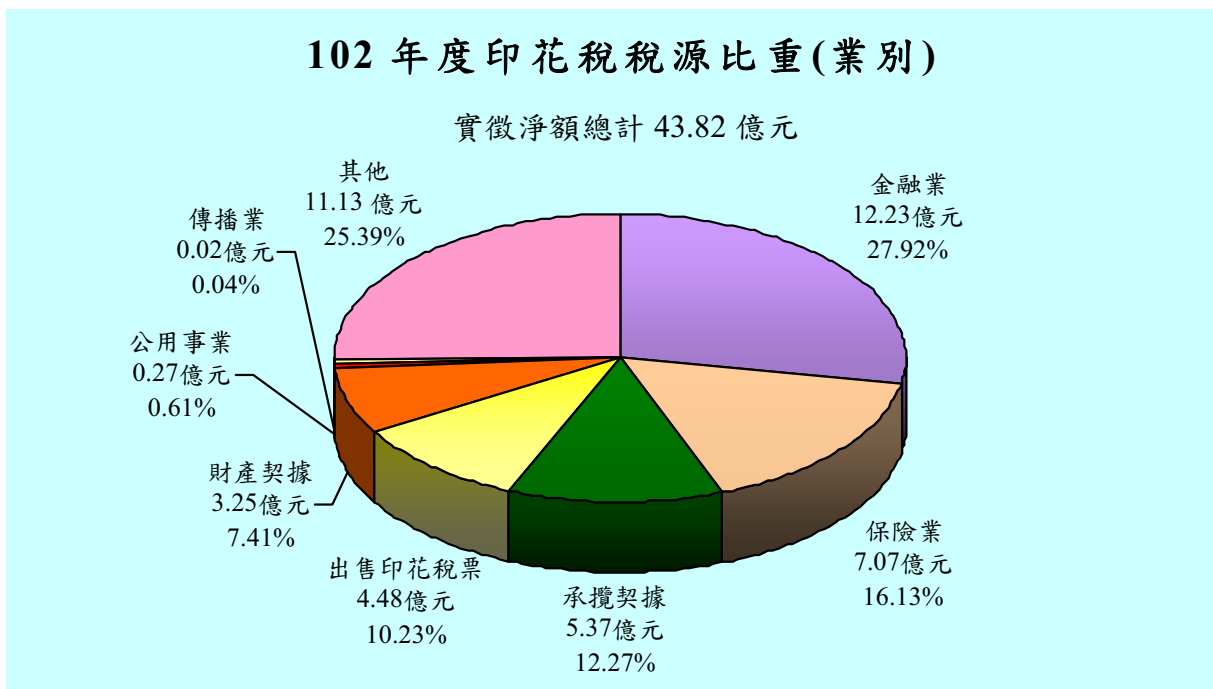
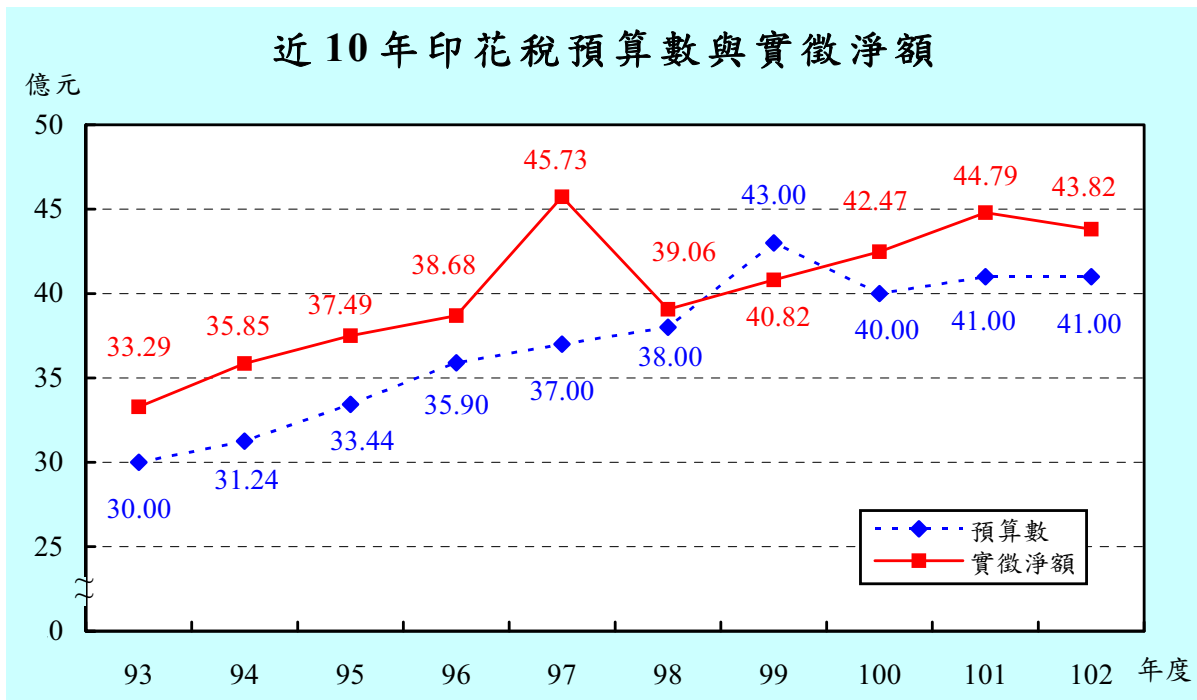

九、娛樂稅

102 年度實徵淨額 2.29 億元，與預算數 2.3 億元比較，減少 0.01 億元，短徵 0.5%；較上年度實徵淨額 2.24 億元增加 0.05 億元，成長 2.1%。

102 年度實徵淨額較 101 年度增加，惟較 102 年度預算數減少，主要原因係臨時性娛樂表演場次不如預期。

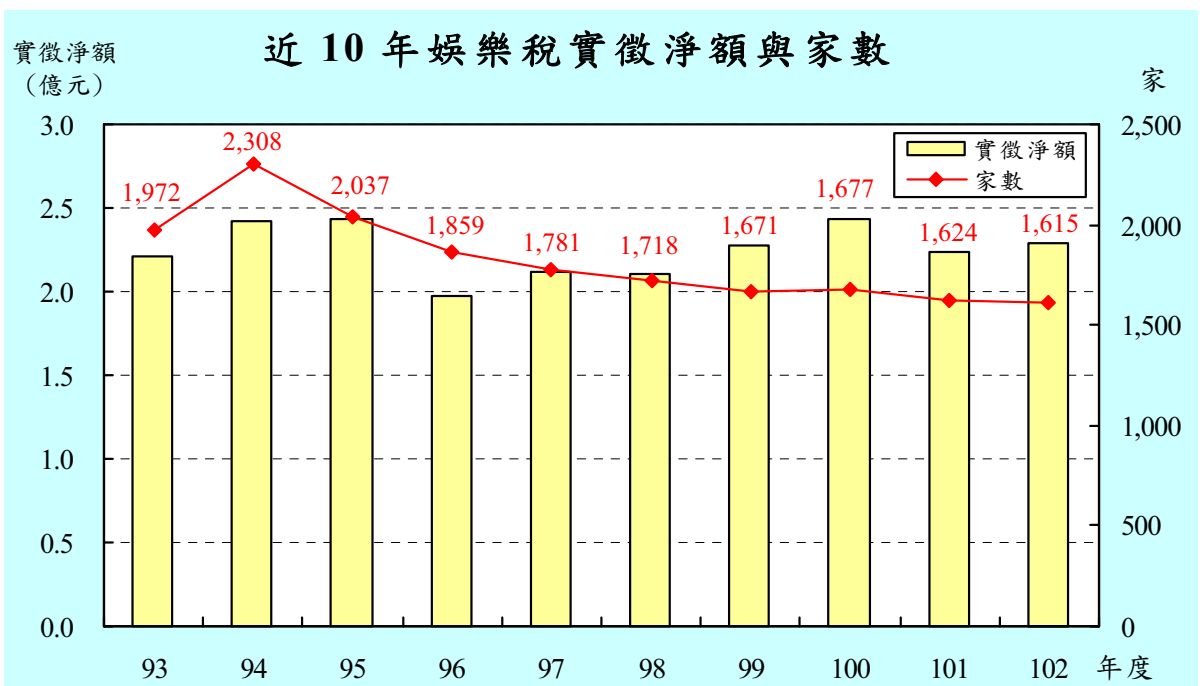
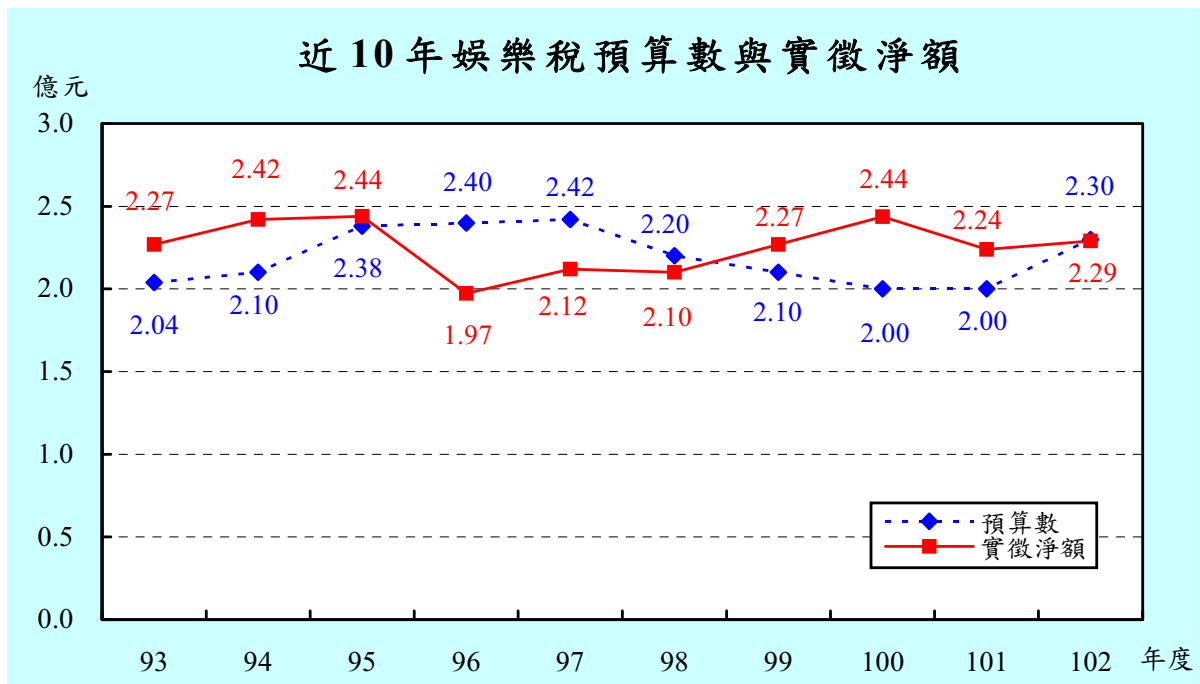

貳、稅收統計

II . Tax Revenue Statistics

表 1 各項稅捐徵績比較

單位：新臺幣千元

稅目別 Item of Tax	102 年 度		FY 2013			
	預算數 Budget Amount	查定數① Audited Amount	實徵數② Actual Collection	退還以前 年度歲入款 Tax Income Returned	實徵淨額 Net Actual Collection	實徵數 占預算數 % Actual Collection/ Budget Amount
總 計 Grand Total	60,561,000	69,598,904	66,673,882	233,351	66,440,531	110.1
稅 課 收 入 Revenues from Taxes	60,430,000	69,105,259	66,530,700	219,981	66,310,719	110.1
地 價 稅 Land Value Tax	21,900,000	23,134,507	22,143,482	57,151	22,086,331	101.1
土 地 增 值 稅 Land Value Increment Tax	14,200,000	20,013,739	19,103,840	131,046	18,972,794	134.5
房 屋 稅 House Tax	11,600,000	12,242,329	11,997,380	21,333	11,976,047	103.4
使 用 牌 照 稅 Vehicle License Tax	6,600,000	7,286,653	6,955,441	5,347	6,950,094	105.4
契 稅 Deed Tax	1,800,000	1,734,852	1,718,308	3,357	1,714,951	95.5
印 花 稅 Stamp Tax	4,100,000	4,450,816	4,383,223	1,722	4,381,501	106.9
娛 樂 稅 Amusement Tax	230,000	241,617	228,951	24	228,927	99.5
教 育 經 費 Education Surtax	—	746	74	—	74	--
工 程 受 益 費 Construction Benefit Fee	—	—	—	—	—	--
罰 鍰 收 入 Punitive Fine Revenue	131,000	493,645	143,182	13,370	129,812	109.3
規 費 收 入 Fees Revenue	—	—	—	—	—	--
契 稅 監 證 費 Fees	—	—	—	—	—	--

資料來源：依據徵課會計報告編製。

附 註：①查定數包括以前年度結轉數。

②實徵數未含實物抵繳稅款(以遞延收入入帳)。

Table 1. Net Tax Revenues Compare

Unit : N.T.\$1,000

實徵淨額 占預算數 % Net Actual Collection/ Budget Amount	102年度與101年度比較 Compare FY2013 with FY2012			101年度與100年度比較 Compare FY2012 with FY2011		
	101年度 實徵淨額 Net Actual Collection FY 2012	增減數 Amount	增減 %	100年度 實徵淨額 Net Actual Collection FY2011	增減數 Amount	增減 %
109.7	62,306,906	4,133,625	6.6	62,159,442	147,464	0.2
109.7	62,189,138	4,121,581	6.6	61,999,268	189,871	0.3
100.9	20,670,524	1,415,807	6.8	20,505,209	165,315	0.8
133.6	16,397,214	2,575,580	15.7	17,407,266	-1,010,052	-5.8
103.2	11,859,935	116,113	1.0	10,865,123	994,811	9.2
105.3	6,827,726	122,368	1.8	6,726,767	100,960	1.5
95.3	1,730,766	- 15,815	-0.9	2,004,331	- 273,565	-13.6
106.9	4,478,571	- 97,071	-2.2	4,246,762	231,810	5.5
99.5	224,138	4,790	2.1	243,807	- 19,670	-8.1
--	264	- 190	-72.1	3	261	8,714.6
--	--	--	--	42	- 42	--
99.1	117,768	12,044	10.2	160,132	- 42,365	- 26.5
--	--	--	--	--	--	--
--	--	--	--	--	--	--

表 2 歷年各項稅捐預算數、查定數與實徵數

(一)總計①

單位：新臺幣元

年度(月)別 Fiscal Year (Month)	預算數 Budget Amount (A)	查定數 Audited Amount		
		合計 Total	本年度 Current FY	以前年度② Previous FY
93 年度 FY 2004	45,137,660,860	65,846,223,776	58,770,576,018	7,075,647,758
94 年度 FY 2005	49,981,343,000	68,597,652,306	61,005,462,738	7,592,189,568
95 年度 FY 2006	52,011,000,000	66,672,822,287	59,184,231,898	7,488,590,389
96 年度 FY 2007	53,276,009,000	68,462,333,538	62,102,868,839	6,359,464,699
97 年度 FY 2008	54,238,000,000	63,451,419,838	57,508,965,836	5,942,454,002
98 年度 FY 2009	53,721,000,000	62,756,930,153	57,011,890,023	5,745,040,130
99 年度 FY 2010	52,865,000,000	65,873,934,825	61,521,291,170	4,352,643,655
100 年度 FY 2011	56,422,260,000	65,754,247,039	61,847,950,043	3,906,296,996
101 年度 FY 2012	61,185,000,000	65,905,662,486	62,733,494,186	3,172,168,300
102 年度 FY 2013	60,561,000,000	69,598,903,684	66,719,824,179	2,879,079,505
1 月 Jan.	2,461,758,000	6,334,325,525	3,278,046,368	3,056,279,157
2 月 Feb.	1,357,269,000	1,643,416,296	1,661,018,798	- 17,602,502
3 月 Mar.	2,618,385,000	2,596,910,892	2,660,434,343	- 63,523,451
4 月 Apr.	4,679,093,000	8,240,081,080	8,216,423,724	23,657,356
5 月 May	11,347,191,000	13,762,353,547	13,780,839,968	- 18,486,421
6 月 June	5,709,648,000	1,945,875,799	1,948,871,357	- 2,995,558
7 月 July	2,187,830,000	2,911,357,975	2,981,448,424	-70,090,449
8 月 Aug.	1,469,721,000	1,467,244,859	1,491,596,054	- 24,351,195
9 月 Sep.	1,945,302,000	1,999,381,367	2,009,659,091	-10,277,724
10 月 Oct.	1,678,118,000	2,410,537,871	2,391,102,907	19,434,964
11 月 Nov.	13,381,343,000	23,830,818,705	23,835,824,056	- 5,005,351
12 月 Dec.	11,725,342,000	2,456,599,768	2,464,559,089	-7,959,321

附註：①總計=稅課收入+工程受益費+罰鍰收入+規費收入(監證費)。

②包括以前年度結轉數。

③99年度起實徵數未含實物抵繳稅款(以遞延收入入帳)。

Table 2. Budget Amount, Audited Amount and Actual Collection
in Recent Years

(I) Grand Total ①

Unit : N.T.\$1

實 徵 數 Actual Collection ③			退還以前年度 歲入款 Tax Income Returned (4)	實 徵 淨 額 Net Actual Collection (1-4=5)	實徵淨額 占預算數 % Net Actual Collection /Budge Amount (5/A)×100
合 計 Total (2+3=1)	本 年 度 Current FY (2)	以 前 年 度 Previous FY (3)			
58,546,075,931	55,922,819,548	2,623,256,383	501,948,741	58,044,127,190	128.6
60,821,499,933	58,345,872,794	2,475,627,139	278,499,442	60,543,000,491	121.1
59,935,082,828	57,140,304,656	2,794,778,172	375,940,451	59,559,142,377	114.5
62,211,212,658	60,107,595,743	2,103,616,915	330,261,624	61,880,951,034	116.2
57,349,343,608	55,240,378,164	2,108,965,444	595,865,819	56,753,477,789	104.6
57,906,303,509	55,585,418,083	2,320,885,426	408,280,057	57,498,023,452	107.0
61,412,898,686	59,915,978,897	1,496,919,789	507,663,766	60,905,234,920	115.2
62,364,742,945	60,525,743,015	1,838,999,930	205,300,912	62,159,442,033	110.2
62,751,393,789	61,392,970,041	1,358,423,748	444,487,791	62,306,905,998	101.8
66,673,882,137	65,467,820,238	1,206,061,899	233,351,037	66,440,531,100	109.7
3,365,291,978	2,913,976,751	451,315,227	40,442,456	3,324,849,522	135.1
1,525,296,538	1,439,565,007	85,731,531	27,724,853	1,497,571,685	110.3
3,023,001,497	2,947,752,891	75,248,606	55,014,531	2,967,986,966	113.4
5,460,528,985	5,260,398,876	200,130,109	9,197,998	5,451,330,987	116.5
11,879,768,049	11,728,318,515	151,449,534	20,997,402	11,858,770,647	104.5
5,886,879,706	5,824,900,276	61,979,430	11,361,183	5,875,518,523	102.9
3,034,437,851	3,068,971,143	-34,533,292	9,320,848	3,025,117,003	138.3
1,679,072,603	1,665,422,552	13,650,051	10,264,708	1,668,807,895	113.5
2,142,374,007	2,115,580,514	26,793,493	8,123,095	2,134,250,912	109.7
2,185,512,109	2,160,324,629	25,187,480	28,083,166	2,157,428,943	128.6
14,100,766,331	14,009,468,789	91,297,542	5,693,179	14,095,073,152	105.3
12,390,952,483	12,333,140,295	57,812,188	7,127,618	12,383,824,865	105.6

表 2 歷年各項稅捐預算數、查定數與實徵數 (續1)

(二)稅課收入

1. 合計

單位：新臺幣元

年度(月)別 Fiscal Year (Month)	預算數 Budget Amount (A)	查定數 Audited Amount		
		合計 Total	本年度 Current FY	以前年度① Previous FY
93 年度 FY 2004	45,014,639,860	65,352,534,743	58,653,423,252	6,699,111,491
94 年度 FY 2005	49,793,343,000	68,132,972,862	60,886,814,259	7,246,158,603
95 年度 FY 2006	51,828,000,000	66,235,324,703	59,111,525,544	7,123,799,159
96 年度 FY 2007	53,093,009,000	68,020,104,766	61,976,402,641	6,043,702,125
97 年度 FY 2008	54,034,000,000	62,976,080,816	57,346,759,662	5,629,321,154
98 年度 FY 2009	53,520,000,000	62,262,066,305	56,854,450,564	5,407,615,741
99 年度 FY 2010	52,710,000,000	65,326,212,670	61,317,097,584	4,009,115,086
100 年度 FY 2011	56,268,260,000	65,190,790,529	61,714,468,538	3,476,321,991
101 年度 FY 2012	61,050,000,000	65,409,563,052	62,634,837,985	2,774,725,067
102 年度 FY 2013	60,430,000,000	69,105,259,084	66,618,323,432	2,486,935,652
1 月 Jan.	2,446,375,000	5,957,481,086	3,268,993,155	2,688,487,931
2 月 Feb.	1,346,073,000	1,635,331,221	1,656,034,486	- 20,703,265
3 月 Mar.	2,607,107,000	2,592,613,782	2,657,920,966	- 65,307,184
4 月 Apr.	4,668,504,000	8,227,981,245	8,211,377,795	16,603,450
5 月 May	11,334,349,000	13,749,344,227	13,768,731,872	- 19,387,645
6 月 June	5,701,278,000	1,931,330,768	1,936,790,634	- 5,459,866
7 月 July	2,176,782,000	2,898,671,886	2,972,037,787	-73,365,901
8 月 Aug.	1,463,332,000	1,462,453,360	1,486,647,187	- 24,193,827
9 月 Sep.	1,934,673,000	1,988,490,303	1,999,654,439	-11,164,136
10 月 Oct.	1,670,832,000	2,396,762,598	2,378,271,881	18,490,717
11 月 Nov.	13,371,643,000	23,824,265,750	23,831,810,664	- 7,544,914
12 月 Dec.	11,709,052,000	2,440,532,858	2,450,052,566	-9,519,708

附註：①包括以前年度結轉數。

②99年度起實徵數未含實物抵繳稅款(以遞延收入入帳)。

Table 2. Budget Amount, Audited Amount and Actual Collection
in Recent Years (Cont. 1)

(II) Revenues from Taxes

1. Total

Unit : N.T.\$1

實 徵 數 Actual Collection ②		退還以前年度 歲入款 Tax Income Returned (4)	實 徵 淨 額 Net Actual Collection (1-4=5)	實徵淨額 占預算數 % Net Actual Collection /Budge Amount (5/A)×100	
合 計 Total (2+3=1)	本 年 度 Current FY (2)				以 前 年 度 Previous FY (3)
58,315,056,227	55,829,055,068	2,486,001,159	454,178,455	57,860,877,772	128.5
60,597,567,284	58,278,178,350	2,319,388,934	265,326,790	60,332,240,494	121.2
59,704,949,774	57,086,468,516	2,618,481,258	371,162,603	59,333,787,171	114.5
62,019,116,746	60,048,819,696	1,970,297,050	323,317,992	61,695,798,754	116.2
57,157,456,189	55,176,188,981	1,981,267,208	586,921,874	56,570,534,315	104.7
57,706,501,696	55,526,927,616	2,179,574,080	361,017,806	57,345,483,890	107.1
61,246,934,737	59,853,800,575	1,393,134,162	402,019,755	60,844,914,982	115.4
62,176,573,002	60,466,079,308	1,710,493,694	177,305,299	61,999,267,703	110.2
62,620,652,883	61,349,810,533	1,270,842,350	431,514,478	62,189,138,405	101.9
66,530,700,040	65,412,535,691	1,118,164,349	219,980,597	66,310,719,443	109.7
3,356,820,476	2,913,638,714	443,181,762	39,908,422	3,316,912,054	135.6
1,512,979,087	1,434,506,028	78,473,059	27,556,842	1,485,422,245	110.4
3,013,898,330	2,946,281,252	67,617,078	48,466,641	2,965,431,689	113.7
5,447,533,761	5,258,441,314	189,092,447	9,050,369	5,438,483,392	116.5
11,865,982,283	11,721,654,045	144,328,238	20,749,288	11,845,232,995	104.5
5,875,179,171	5,820,745,815	54,433,356	11,124,458	5,864,054,713	102.9
3,022,766,479	3,064,875,074	-42,108,595	9,249,293	3,013,517,186	138.4
1,671,024,617	1,663,002,049	8,022,568	9,992,705	1,661,031,912	113.5
2,131,599,939	2,111,343,858	20,256,081	7,840,149	2,123,759,790	109.8
2,173,702,532	2,155,054,209	18,648,323	23,651,895	2,150,050,637	128.7
14,090,443,336	14,005,281,105	85,162,231	5,568,298	14,084,875,038	105.3
12,368,770,029	12,317,712,228	51,057,801	6,822,237	12,361,947,792	105.6

表 2 歷年各項稅捐預算數、查定數與實徵數 (續2)

(二)稅課收入

2. 地價稅

單位：新臺幣元

年度(月)別 Fiscal Year (Month)	預算數 Budget Amount (A)	查定數 Audited Amount		
		合計 Total	本年度 Current FY	以前年度 Previous FY
93 年度 FY 2004	16,681,444,000	20,566,603,064	17,488,292,574	3,078,310,490
94 年度 FY 2005	16,697,695,000	21,023,343,012	17,744,063,944	3,279,279,068
95 年度 FY 2006	16,841,000,000	20,877,369,503	17,631,744,847	3,245,624,656
96 年度 FY 2007	17,037,000,000	22,406,238,656	19,665,335,019	2,740,903,637
97 年度 FY 2008	17,600,000,000	21,622,348,590	18,962,431,757	2,659,916,833
98 年度 FY 2009	17,800,000,000	20,775,773,127	18,637,378,171	2,138,394,956
99 年度 FY 2010	18,000,000,000	22,108,091,007	20,315,591,574	1,792,499,433
100 年度 FY 2011	18,400,000,000	21,729,735,988	20,213,024,931	1,516,711,057
101 年度 FY 2012	19,500,000,000	21,916,615,715	20,793,949,827	1,122,665,888
102 年度 FY 2013	21,900,000,000	23,134,506,730	22,091,728,224	1,042,778,506
1 月 Jan.	122,951,000	1,139,396,304	9,429,714	1,129,966,590
2 月 Feb.	67,136,000	3,023,732	14,455,708	- 11,431,976
3 月 Mar.	89,540,000	19,346,985	24,474,440	- 5,127,455
4 月 Apr.	179,090,000	14,145,753	17,369,720	- 3,223,967
5 月 May	139,394,000	21,552,770	27,465,075	- 5,912,305
6 月 June	52,577,000	39,457,507	40,524,525	- 1,067,018
7 月 July	69,272,000	-60,857,036	11,869,443	- 72,726,479
8 月 Aug.	44,473,000	5,748,271	8,778,719	- 3,030,448
9 月 Sep.	46,084,000	10,891,449	11,770,515	-879,066
10 月 Oct.	268,503,000	516,789,180	495,896,693	20,892,487
11 月 Nov.	11,027,795,000	21,258,886,610	21,259,693,724	- 807,114
12 月 Dec.	9,793,185,000	166,125,205	169,999,948	-3,874,743

Table 2. Budget Amount, Audited Amount and Actual Collection
in Recent Years (Cont. 2)

(II) Revenues from Taxes

2. Land Value Tax

Unit : N.T.\$1

實徵數 Actual Collection			退還以前年度 歲入款 Tax Income Returned	實徵淨額 Net Actual Collection	實徵淨額 占預算數 % Net Actual Collection /Budge Amount
合計 Total (2+3=1)	本年度 Current FY (2)	以前年度 Previous FY (3)			
17,245,631,135	16,237,683,296	1,007,947,839	139,724,220	17,105,906,915	102.5
17,642,901,242	16,674,917,773	967,983,469	85,128,173	17,557,773,069	105.2
17,966,408,173	16,742,406,708	1,224,001,465	65,594,730	17,900,813,443	106.3
19,562,228,351	18,649,206,309	913,022,042	93,531,178	19,468,697,173	114.3
19,336,852,287	18,205,651,270	1,131,201,017	148,458,460	19,188,393,827	109.0
18,836,109,030	18,029,123,615	806,985,415	133,715,429	18,702,393,601	105.1
20,332,765,697	19,623,815,795	708,949,902	41,724,158	20,291,041,539	112.7
20,534,137,009	19,743,790,367	790,346,642	28,928,504	20,505,208,505	111.4
20,748,021,644	20,243,111,064	504,910,580	77,497,739	20,670,523,905	106.0
22,143,481,947	21,644,233,803	499,248,144	57,150,883	22,086,331,064	100.9
94,590,700	8,146,268	86,444,432	9,225,200	85,365,500	69.4
41,675,400	2,358,460	39,316,940	2,372,956	39,302,444	58.5
70,217,048	29,424,220	40,792,828	15,599,302	54,617,746	61.0
165,641,869	5,722,058	159,919,811	1,526,165	164,115,704	91.6
99,964,219	21,863,283	78,100,936	1,388,111	98,576,108	70.7
35,681,909	8,387,846	27,294,063	417,748	35,264,161	67.1
-38,944,280	16,300,988	-55,245,268	301,128	-39,245,408	-56.7
25,238,245	15,714,939	9,523,306	875,877	24,362,368	54.8
36,410,537	23,280,440	13,130,097	3,439,525	32,971,012	71.5
466,378,127	457,805,152	8,572,975	18,129,144	448,248,983	166.9
11,429,782,324	11,356,923,983	72,858,341	2,290,399	11,427,491,925	103.6
9,716,845,849	9,698,306,166	18,539,683	1,585,328	9,715,260,521	99.2

表 2 歷年各項稅捐預算數、查定數與實徵數 (續3)

(二)稅課收入

3. 土地增值稅

單位：新臺幣元

年度(月)別 Fiscal Year (Month)	預算數 Budget Amount (A)	查定數 Audited Amount		
		合計 Total	本年度 Current FY	以前年度 Previous FY
93 年度 FY 2004	8,511,878,000	20,700,072,384	19,299,421,992	1,400,650,392
94 年度 FY 2005	12,600,000,000	22,419,548,012	20,699,450,225	1,720,097,787
95 年度 FY 2006	13,800,000,000	20,479,966,834	18,573,005,660	1,906,961,174
96 年度 FY 2007	14,271,009,000	20,581,406,339	19,082,471,654	1,498,934,685
97 年度 FY 2008	14,400,000,000	15,838,196,306	14,501,930,736	1,336,265,570
98 年度 FY 2009	13,500,000,000	16,754,143,332	14,953,917,653	1,800,225,679
99 年度 FY 2010	12,000,000,000	18,231,273,864	17,212,755,478	1,018,518,386
100 年度 FY 2011	15,000,000,000	18,530,330,855	17,550,051,311	980,279,544
101 年度 FY 2012	17,000,000,000	17,566,789,041	16,633,841,191	932,947,850
102 年度 FY 2013	14,200,000,000	20,013,739,423	19,214,772,442	798,966,981
1 月 Jan.	1,363,092,000	3,103,477,821	2,260,337,636	843,140,185
2 月 Feb.	968,772,000	1,335,101,433	1,339,944,795	- 4,843,362
3 月 Mar.	1,494,022,000	1,498,738,606	1,548,210,111	- 49,471,505
4 月 Apr.	1,018,368,000	1,527,802,196	1,501,255,365	26,546,831
5 月 May	1,174,635,000	1,440,572,322	1,443,586,821	- 3,014,499
6 月 June	1,197,719,000	1,584,664,292	1,584,720,781	- 56,489
7 月 July	1,195,870,000	2,015,881,974	2,015,881,974	—
8 月 Aug.	1,017,041,000	1,210,876,357	1,224,544,550	- 13,668,193
9 月 Sep.	1,057,780,000	1,207,513,356	1,207,513,356	—
10 月 Oct.	961,977,000	1,316,111,646	1,314,692,803	1,418,843
11 月 Nov.	1,286,133,000	1,855,362,015	1,856,238,063	- 876,048
12 月 Dec.	1,464,591,000	1,917,637,405	1,917,846,187	-208,782

附註：1、91年2月1日至94年1月31日止土地增值稅減半徵收3年。

2、自94年2月1日起一般用地稅率調降為20%、30%、40%。

Table 2. Budget Amount, Audited Amount and Actual Collection
in Recent Years (Cont. 3)

(II) Revenues from Taxes

3. Land Value Increment Tax

Unit : N.T.\$1

實徵數 Actual Collection			退還以前年度 歲入款 Tax Income Returned (4)	實徵淨額 Net Actual Collection (1-4=5)	實徵淨額 占預算數 % Net Actual Collection /Budge Amount (5/A)×100
合計 Total (2+3=1)	本年度 Current FY (2)	以前年度 Previous FY (3)			
19,527,565,086	18,559,316,795	968,248,291	278,117,108	19,249,447,978	226.1
20,417,762,328	19,665,600,010	752,162,318	162,801,073	20,254,961,255	160.8
18,880,808,661	17,906,518,152	974,290,509	272,719,849	18,608,088,812	134.8
19,209,882,958	18,552,463,723	657,419,235	172,100,151	19,037,782,807	133.4
13,943,736,263	13,477,042,093	466,694,170	394,326,670	13,549,409,593	94.1
15,609,940,194	14,555,621,276	1,054,318,918	196,024,352	15,413,915,842	114.2
17,088,982,865	16,718,462,793	370,520,072	204,092,581	16,884,890,284	140.7
17,528,534,334	16,992,903,207	535,631,127	121,268,101	17,407,266,233	116.0
16,674,777,843	16,137,848,941	536,928,902	277,563,791	16,397,214,052	96.5
19,103,840,213	18,728,768,054	375,072,159	131,046,359	18,972,793,854	133.6
2,244,260,074	1,962,731,668	281,528,406	25,528,638	2,218,731,436	162.8
1,173,005,060	1,151,909,485	21,095,575	21,399,299	1,151,605,761	118.9
1,827,941,371	1,817,589,747	10,351,624	16,884,427	1,811,056,944	121.2
1,211,471,523	1,197,218,345	14,253,178	6,883,720	1,204,587,803	118.3
1,451,880,629	1,422,682,459	29,198,170	18,014,812	1,433,865,817	122.1
1,432,005,068	1,414,803,733	17,201,335	8,799,669	1,423,205,399	118.8
2,081,660,365	2,080,149,620	1,510,745	8,553,934	2,073,106,431	173.4
1,210,719,167	1,218,190,980	-7,471,813	8,217,860	1,202,501,307	118.2
1,273,324,568	1,273,217,485	107,083	3,839,190	1,269,485,378	120.0
1,318,838,229	1,314,767,796	4,070,433	5,240,810	1,313,597,419	136.6
1,611,328,006	1,611,280,697	47,309	3,005,392	1,608,322,614	125.1
2,267,406,153	2,264,226,039	3,180,114	4,678,608	2,262,727,545	154.5

表 2 歷年各項稅捐預算數、查定數與實徵數 (續4)

(二)稅課收入

4. 房屋稅

單位：新臺幣元

年度(月)別 Fiscal Year (Month)	預算數 Budget Amount (A)	查定數 Audited Amount		
		合計 Total	本年度 Current FY	以前年度 Previous FY
93 年度 FY 2004	9,139,824,000	10,695,487,923	9,545,780,030	1,149,707,893
94 年度 FY 2005	9,465,383,000	10,990,080,178	9,728,720,000	1,261,360,178
95 年度 FY 2006	9,641,000,000	11,066,349,485	9,998,789,101	1,067,560,384
96 年度 FY 2007	9,750,000,000	11,110,055,367	10,093,474,972	1,016,580,395
97 年度 FY 2008	9,800,000,000	11,078,405,809	10,126,254,227	952,151,582
98 年度 FY 2009	9,900,000,000	11,165,748,863	10,287,985,782	877,763,081
99 年度 FY 2010	10,000,000,000	11,216,744,220	10,584,535,806	632,208,414
100 年度 FY 2011	10,268,260,000	11,195,589,644	10,724,497,031	471,092,613
101 年度 FY 2012	11,400,000,000	12,145,931,799	11,853,364,805	292,566,994
102 年度 FY 2013	11,600,000,000	12,242,328,975	11,981,068,357	261,260,618
1 月 Jan.	26,058,000	304,525,598	28,217,246	276,308,352
2 月 Feb.	17,592,000	25,595,604	25,906,244	- 310,640
3 月 Mar.	28,936,000	20,998,332	28,536,449	- 7,538,117
4 月 Apr.	122,702,000	390,321,323	391,010,937	- 689,614
5 月 May	6,971,507,000	11,446,242,864	11,451,235,246	- 4,992,382
6 月 June	4,129,065,000	13,944,114	14,803,100	- 858,986
7 月 July	57,837,000	4,932,687	5,022,161	- 89,474
8 月 Aug.	33,078,000	-4,599,780	-4,166,615	- 433,165
9 月 Sep.	27,465,000	6,470,335	6,660,381	- 190,046
10 月 Oct.	91,528,000	9,086,634	9,062,697	23,937
11 月 Nov.	47,361,000	11,224,174	11,265,188	- 41,014
12 月 Dec.	46,871,000	13,587,090	13,515,323	71,767

Table 2. Budget Amount, Audited Amount and Actual Collection
in Recent Years (Cont. 4)

(II) Revenues from Taxes

4. House Tax

Unit : N.T.\$1

實徵數 Actual Collection			退還以前年度 歲入款 Tax Income Returned	實徵淨額 Net Actual Collection	實徵淨額 占預算數 % Net Actual Collection /Budge Amount (5/A)×100
合計 Total (2+3=1)	本年度 Current FY (2)	以前年度 Previous FY (3)			
9,408,383,446	9,159,646,344	248,737,102	15,317,628	9,393,065,818	102.8
9,897,451,617	9,511,123,127	386,328,490	7,244,799	9,890,206,818	104.5
10,008,945,199	9,801,976,281	206,968,918	11,239,378	9,997,705,821	103.7
10,107,330,035	9,936,615,687	170,714,348	16,058,978	10,091,271,057	103.5
10,147,929,725	9,971,769,272	176,160,453	7,309,474	10,140,620,251	103.5
10,307,459,162	10,167,653,129	139,806,033	11,972,825	10,295,486,337	104.0
10,627,295,631	10,486,926,494	140,369,137	126,758,102	10,500,537,529	105.0
10,873,867,433	10,640,949,149	232,918,284	8,744,070	10,865,123,363	105.8
11,869,544,305	11,765,750,542	103,793,763	9,609,521	11,859,934,784	104.0
11,997,380,436	11,884,758,971	112,621,465	21,333,121	11,976,047,315	103.2
37,901,426	24,895,633	13,005,793	488,036	37,413,390	143.6
25,990,879	16,842,658	9,148,221	2,503,754	23,487,125	133.5
32,464,687	26,248,155	6,216,532	15,161,435	17,303,252	59.8
380,913,872	374,715,016	6,198,856	475,460	380,438,412	310.1
7,192,219,482	7,162,909,964	29,309,518	1,143,580	7,191,075,902	103.1
4,057,136,684	4,053,464,001	3,672,683	387,408	4,056,749,276	98.2
55,605,630	52,283,194	3,322,436	199,364	55,406,266	95.8
27,108,780	24,095,488	3,013,292	365,607	26,743,173	80.8
26,900,320	24,285,137	2,615,183	152,937	26,747,383	97.4
45,659,647	43,843,357	1,816,290	218,646	45,441,001	49.6
66,743,000	58,507,873	8,235,127	64,647	66,678,353	140.8
48,736,029	22,668,495	26,067,534	172,247	48,563,782	103.6

表 2 歷年各項稅捐預算數、查定數與實徵數 (續5)

(二)稅課收入

5. 使用牌照稅

單位：新臺幣元

年度(月)別 Fiscal Year (Month)	預算數 Budget Amount (A)	查定數 Audited Amount		
		合計 Total	本年度 Current FY	以前年度 Previous FY
93 年度 FY 2004	5,877,642,860	7,280,659,398	6,361,942,761	918,716,637
94 年度 FY 2005	6,096,208,000	7,375,409,176	6,508,892,037	866,517,139
95 年度 FY 2006	6,390,000,000	7,279,956,795	6,501,992,897	777,963,898
96 年度 FY 2007	6,585,000,000	7,236,551,078	6,569,504,486	667,046,592
97 年度 FY 2008	6,592,000,000	7,146,127,212	6,566,865,409	579,261,803
98 年度 FY 2009	6,500,000,000	7,003,421,917	6,486,376,074	517,045,843
99 年度 FY 2010	6,300,000,000	7,057,513,192	6,557,727,685	499,785,507
100 年度 FY 2011	6,400,000,000	7,172,227,550	6,720,258,884	451,968,666
101 年度 FY 2012	6,450,000,000	7,210,013,827	6,833,694,476	376,319,351
102 年度 FY 2013	6,600,000,000	7,286,652,627	6,966,480,016	320,172,611
1 月 Jan.	100,898,000	492,175,587	119,358,012	372,817,575
2 月 Feb.	84,597,000	68,100,741	71,913,011	- 3,812,270
3 月 Mar.	306,626,000	321,782,257	324,456,963	-2,674,706
4 月 Apr.	3,098,784,000	6,001,017,345	6,006,828,151	- 5,810,806
5 月 May	2,353,239,000	21,621,884	26,692,452	- 5,070,568
6 月 June	72,158,000	11,977,575	15,213,041	- 3,235,466
7 月 July	91,526,000	22,429,162	24,592,155	- 2,162,993
8 月 Aug.	83,374,000	7,659,443	12,619,009	- 4,959,566
9 月 Sep.	31,388,000	9,914,787	19,990,675	- 10,075,888
10 月 Oct.	99,813,000	333,608,864	337,285,152	- 3,676,288
11 月 Nov.	256,726,000	2,515,286	8,332,660	- 5,817,374
12 月 Dec.	20,871,000	-6,150,304	-801,265	-5,349,039

附註：計程車客運業自94年12月2日起免徵使用牌照稅。

Table 2. Budget Amount, Audited Amount and Actual Collection
in Recent Years (Cont. 5)

(II) Revenues from Taxes

5. Vehicle License Tax

Unit : N.T.\$1

實徵數 Actual Collection			退還以前年度 歲入款 Tax Income Returned	實徵淨額 Net Actual Collection	實徵淨額 占預算數 % Net Actual Collection /Budge Amount
合計 Total (2+3=1)	本年度 Current FY (2)	以前年度 Previous FY (3)			
6,348,330,685	6,139,733,877	208,596,808	3,575,857	6,344,754,828	107.9
6,475,038,293	6,288,700,519	186,337,774	3,521,817	6,471,516,476	106.2
6,456,855,906	6,282,770,037	174,085,869	14,106,973	6,442,748,933	100.8
6,570,266,092	6,387,577,512	182,688,580	8,119,825	6,562,146,267	99.7
6,557,721,371	6,391,932,046	165,789,325	21,283,375	6,536,437,996	99.2
6,471,544,379	6,327,495,599	144,048,780	9,534,915	6,462,009,464	99.4
6,555,896,936	6,423,796,664	132,100,272	13,827,036	6,542,069,900	103.8
6,734,678,663	6,623,516,937	111,161,726	7,912,188	6,726,766,475	105.1
6,833,177,948	6,746,233,733	86,944,215	5,451,652	6,827,726,296	105.9
6,955,441,436	6,877,052,975	78,388,461	5,347,283	6,950,094,153	105.3
124,006,180	110,519,364	13,486,816	2,657,425	121,348,755	120.3
81,142,677	73,684,609	7,458,068	899,388	80,243,289	94.9
327,709,694	318,296,935	9,412,759	604,982	327,104,712	106.7
3,412,520,387	3,404,790,272	7,730,115	155,581	3,412,364,806	110.1
2,295,944,781	2,288,352,761	7,592,020	150,577	2,295,794,204	97.6
77,448,815	71,317,962	6,130,853	130,604	77,318,211	107.2
104,047,928	97,669,554	6,378,374	102,875	103,945,053	113.6
86,303,084	81,572,774	4,730,310	80,819	86,222,265	103.4
40,184,080	35,905,132	4,278,948	92,350	40,091,730	127.7
126,097,972	122,000,347	4,097,625	56,646	126,041,326	126.3
253,331,618	249,418,790	3,912,828	204,074	253,127,544	98.6
26,704,220	23,524,475	3,179,745	211,962	26,492,258	126.9

表 2 歷年各項稅捐預算數、查定數與實徵數 (續6)

(二)稅課收入

6. 契稅

單位：新臺幣元

年度(月)別 Fiscal Year (Month)	預算數 Budget Amount (A)	查定數 Audited Amount		
		合計 Total	本年度 Current FY	以前年度 Previous FY
93 年度 FY 2004	1,600,000,000	2,440,714,092	2,389,524,188	51,189,904
94 年度 FY 2005	1,600,000,000	2,370,146,499	2,343,929,540	26,216,959
95 年度 FY 2006	1,574,000,000	2,437,482,207	2,404,929,193	32,553,014
96 年度 FY 2007	1,620,000,000	2,505,084,139	2,471,335,039	33,749,100
97 年度 FY 2008	1,700,000,000	2,400,691,064	2,376,222,441	24,468,623
98 年度 FY 2009	1,800,000,000	2,387,423,390	2,370,494,063	16,929,327
99 年度 FY 2010	1,900,000,000	2,354,950,169	2,335,370,733	19,579,436
100 年度 FY 2011	2,000,000,000	2,024,703,077	2,004,885,156	19,817,921
101 年度 FY 2012	2,400,000,000	1,801,127,687	1,789,084,593	12,043,094
102 年度 FY 2013	1,800,000,000	1,734,852,208	1,715,325,749	19,526,459
1 月 Jan.	160,820,000	234,266,668	214,552,539	19,714,129
2 月 Feb.	118,734,000	99,318,075	99,438,476	- 120,401
3 月 Mar.	159,165,000	144,621,917	144,851,993	- 230,076
4 月 Apr.	141,716,000	162,546,741	162,520,967	25,774
5 月 May	148,228,000	147,002,773	147,108,642	- 105,869
6 月 June	144,448,000	140,306,794	140,275,820	30,974
7 月 July	159,909,000	237,330,112	237,356,513	- 26,401
8 月 Aug.	141,731,000	98,342,892	98,342,892	—
9 月 Sep.	123,393,000	106,653,430	106,653,430	—
10 月 Oct.	144,302,000	57,259,108	57,259,108	—
11 月 Nov.	165,067,000	130,727,979	130,490,573	237,406
12 月 Dec.	192,487,000	176,475,719	176,474,796	923

Table 2. Budget Amount, Audited Amount and Actual Collection
in Recent Years (Cont. 6)

(II) Revenues from Taxes

6.Deed Tax

Unit : N.T.\$1

實徵數 Actual Collection			退還以前年度 歲入款 Tax Income Returned	實徵淨額 Net Actual Collection	實徵淨額 占預算數 % Net Actual Collection /Budge Amount
合計 Total (2+3=1)	本年度 Current FY (2)	以前年度 Previous FY (3)			
2,215,404,272	2,174,423,795	40,980,477	5,706,751	2,209,697,521	138.1
2,331,208,817	2,314,331,866	16,876,951	3,072,424	2,328,136,393	145.5
2,395,511,426	2,372,214,627	23,296,799	5,651,175	2,389,860,251	151.8
2,482,531,926	2,455,891,723	26,640,203	13,565,211	2,468,966,715	152.4
2,373,419,350	2,355,450,922	17,968,428	4,332,477	2,369,086,873	139.4
2,362,740,281	2,349,557,652	13,182,629	5,738,532	2,357,001,749	130.9
2,331,574,422	2,314,250,777	17,323,645	4,427,193	2,327,147,229	122.5
2,009,354,997	1,990,445,604	18,909,393	5,023,858	2,004,331,139	100.2
1,779,320,448	1,767,832,856	11,487,592	48,554,638	1,730,765,810	72.1
1,718,308,296	1,699,547,000	18,761,296	3,357,047	1,714,951,249	95.3
217,644,600	199,177,008	18,467,592	1,704,754	215,939,846	134.3
91,304,447	91,094,127	210,320	330,571	90,973,876	76.6
151,273,722	151,192,644	81,078	196,634	151,077,088	94.9
150,155,005	150,151,292	3,713	9,438	150,145,567	105.9
157,853,436	157,887,330	-33,894	51,450	157,801,986	106.5
132,173,262	132,164,152	9,110	314,268	131,858,994	91.3
141,628,970	141,620,169	8,801	91,992	141,536,978	88.5
169,810,172	169,810,172	—	160,314	169,649,858	119.7
105,473,518	105,473,518	—	316,042	105,157,476	85.2
100,505,834	100,495,749	10,085	6,648	100,499,186	69.6
119,386,321	119,391,454	-5,133	3,786	119,382,535	72.3
181,099,009	181,089,385	9,624	171,150	180,927,859	94.0

表 2 歷年各項稅捐預算數、查定數與實徵數 (續7)

(二)稅課收入

7. 印花稅

單位：新臺幣元

年度(月)別 Fiscal Year (Month)	預算數 Budget Amount (A)	查定數 Audited Amount		
		合計 Total	本年度 Current FY	以前年度 Previous FY
93 年度 FY 2004	3,000,000,000	3,346,641,084	3,337,759,773	8,881,311
94 年度 FY 2005	3,124,057,000	3,622,353,250	3,615,572,362	6,780,888
95 年度 FY 2006	3,344,000,000	3,766,379,307	3,755,601,122	10,778,185
96 年度 FY 2007	3,590,000,000	3,888,454,981	3,873,555,888	14,899,093
97 年度 FY 2008	3,700,000,000	4,609,282,181	4,588,774,708	20,507,473
98 年度 FY 2009	3,800,000,000	3,925,051,668	3,906,121,491	18,930,177
99 年度 FY 2010	4,300,000,000	4,104,312,940	4,082,135,308	22,177,632
100 年度 FY 2011	4,000,000,000	4,276,000,815	4,256,320,858	19,679,957
101 年度 FY 2012	4,100,000,000	4,528,289,507	4,503,633,420	24,656,087
102 年度 FY 2013	4,100,000,000	4,450,816,446	4,420,195,497	30,620,949
1 月 Jan.	653,314,000	649,453,418	618,746,281	30,707,137
2 月 Feb.	68,036,000	86,794,263	86,861,179	- 66,916
3 月 Mar.	508,019,000	570,500,447	570,493,484	6,963
4 月 Apr.	91,072,000	112,675,212	112,702,676	-27,464
5 月 May	525,876,000	652,764,474	652,741,335	23,139
6 月 June	84,134,000	122,934,099	122,934,267	- 168
7 月 July	585,296,000	655,186,125	653,356,676	1,829,449
8 月 Aug.	123,919,000	120,747,916	122,605,321	-1,857,405
9 月 Sep.	628,685,000	625,382,188	625,382,188	—
10 月 Oct.	85,939,000	147,703,769	147,703,769	—
11 月 Nov.	571,282,000	551,437,096	551,429,621	7,475
12 月 Dec.	174,428,000	155,237,439	155,238,700	-1,261

Table 2. Budget Amount, Audited Amount and Actual Collection
in Recent Years (Cont. 7)

(II) Revenues from Taxes

7. Stamp Tax

Unit : N.T.\$1

實徵數 Actual Collection			退還以前年度 歲入款 Tax Income Returned	實徵淨額 Net Actual Collection	實徵淨額 占預算數 % Net Actual Collection /Budge Amount
合計 Total (2+3=1)	本年度 Current FY (2)	以前年度 Previous FY (3)			
3,340,833,549	3,337,591,413	3,242,136	11,613,815	3,329,219,734	111.0
3,588,199,738	3,585,960,872	2,238,866	3,545,063	3,584,654,675	114.7
3,751,018,926	3,741,648,032	9,370,894	1,713,858	3,749,305,068	112.1
3,868,754,971	3,854,892,522	13,862,449	437,622	3,868,317,349	107.8
4,575,045,907	4,555,749,565	19,296,342	1,704,717	4,573,341,190	123.6
3,908,255,404	3,890,354,445	17,900,959	2,724,686	3,905,530,718	102.8
4,082,809,119	4,061,562,012	21,247,107	492,895	4,082,316,224	94.9
4,251,545,414	4,232,189,023	19,356,391	4,783,867	4,246,761,547	106.2
4,490,891,015	4,466,449,592	24,441,423	12,319,234	4,478,571,781	109.2
4,383,222,779	4,352,816,494	30,406,285	1,721,851	4,381,500,928	106.9
620,065,212	590,610,762	29,454,450	297,103	619,768,109	94.9
84,332,140	83,420,410	911,730	48,877	84,283,263	123.9
584,930,495	584,891,619	38,876	8,119	584,922,376	115.1
106,702,709	106,702,709	—	5	106,702,704	117.2
648,269,608	648,246,469	23,139	758	648,268,850	123.3
122,108,667	122,108,835	- 168	1,074,761	121,033,906	143.9
654,721,279	652,907,026	1,814,253	—	654,721,279	111.9
127,964,270	129,806,479	-1,842,209	292,228	127,672,042	103.0
628,665,119	628,665,119	—	—	628,665,119	100.0
99,243,543	99,243,543	—	—	99,243,543	115.5
595,693,586	595,687,372	6,214	—	595,693,586	104.3
110,526,151	110,526,151	—	—	110,526,151	63.4

表 2 歷年各項稅捐預算數、查定數與實徵數 (續8)

(二)稅課收入

8. 娛樂稅

單位：新臺幣元

年度(月)別 Fiscal Year (Month)	預算數 Budget Amount (A)	查定數 Audited Amount		
		合計 Total	本年度 Current FY	以前年度 Previous FY
93 年度 FY 2004	203,851,000	290,540,571	230,696,490	59,844,081
94 年度 FY 2005	210,000,000	305,317,612	246,157,608	59,160,004
95 年度 FY 2006	238,000,000	305,881,025	245,462,724	60,418,301
96 年度 FY 2007	240,000,000	275,783,980	220,725,583	55,058,397
97 年度 FY 2008	242,000,000	268,489,788	224,280,384	44,209,404
98 年度 FY 2009	220,000,000	242,229,432	212,177,330	30,052,102
99 年度 FY 2010	210,000,000	248,327,528	228,981,000	19,346,528
100 年度 FY 2011	200,000,000	259,975,890	245,430,367	14,545,523
101 年度 FY 2012	200,000,000	239,594,695	227,269,673	12,325,022
102 年度 FY 2013	230,000,000	241,617,104	228,753,147	12,863,957
1 月 Jan.	19,242,000	33,292,704	18,351,727	14,940,977
2 月 Feb.	21,206,000	17,397,373	17,515,073	- 117,700
3 月 Mar.	20,799,000	16,625,238	16,897,526	- 272,288
4 月 Apr.	16,772,000	19,472,675	19,689,979	- 217,304
5 月 May	21,470,000	19,620,794	19,902,301	- 281,507
6 月 June	21,177,000	18,160,148	18,319,100	- 158,952
7 月 July	17,072,000	23,767,472	23,957,475	- 190,003
8 月 Aug.	19,716,000	23,679,651	23,924,701	- 245,050
9 月 Sep.	19,878,000	21,664,758	21,683,894	- 19,136
10 月 Oct.	18,770,000	16,203,397	16,371,659	- 168,262
11 月 Nov.	17,279,000	14,112,590	14,360,835	- 248,245
12 月 Dec.	16,619,000	17,620,304	17,778,877	-158,573

Table 2. Budget Amount, Audited Amount and Actual Collection
in Recent Years (Cont. 8)

(II) Revenues from Taxes

8. Amusement Tax

Unit : N.T.\$1

實徵數 Actual Collection			退還以前年度 歲入款 Tax Income Returned (4)	實徵淨額 Net Actual Collection (1-4=5)	實徵淨額 占預算數 % Net Actual Collection /Budge Amount (5/A)×100
合計 Total (2+3=1)	本年度 Current FY (2)	以前年度 Previous FY (3)			
226,986,463	220,654,104	6,332,359	121,561	226,864,902	111.3
242,091,551	237,515,640	4,575,911	4,027	242,087,524	115.3
244,097,516	238,934,679	5,162,837	97,763	243,999,753	102.5
216,736,034	212,172,220	4,563,814	19,492,764	197,243,270	82.2
221,995,693	218,593,813	3,401,880	9,506,701	212,488,992	87.8
210,098,246	207,121,900	2,976,346	75,284	210,022,962	95.5
226,941,170	224,986,040	1,955,130	68,614	226,872,556	108.0
244,111,111	242,285,021	1,826,090	303,664	243,807,447	121.9
224,615,319	222,583,805	2,031,514	477,451	224,137,868	112.1
228,951,423	225,358,394	3,593,029	24,053	228,927,370	99.5
18,352,284	17,558,011	794,273	7,266	18,345,018	95.3
15,506,372	15,196,279	310,093	1,997	15,504,375	73.1
19,361,313	18,637,932	723,381	11,742	19,349,571	93.0
20,128,396	19,141,622	986,774	—	20,128,396	120.0
19,850,128	19,711,779	138,349	—	19,850,128	92.5
18,573,368	18,499,286	74,082	—	18,573,368	87.7
24,046,587	23,944,523	102,064	—	24,046,587	140.9
23,880,899	23,811,217	69,682	—	23,880,899	121.1
20,641,797	20,517,027	124,770	105	20,641,692	103.8
16,979,180	16,898,265	80,915	1	16,979,179	90.5
14,178,481	14,070,936	107,545	—	14,178,481	82.1
17,452,618	17,371,517	81,101	2,942	17,449,676	105.0

表 2 歷年各項稅捐預算數、查定數與實徵數 (續9)

(二)稅課收入

9. 九年國民義務教育附徵教育經費

單位：新臺幣元

(1)小計

年度(月)別 Fiscal Year (Month)	預算數 Budget Amount (A)	查定數 Audited Amount		
		合計 Total	本年度 Current FY	以前年度 Previous FY
93 年度 FY 2004	—	31,816,227	5,444	31,810,783
94 年度 FY 2005	—	26,775,123	28,543	26,746,580
95 年度 FY 2006	—	21,939,547	—	21,939,547
96 年度 FY 2007	—	16,530,226	—	16,530,226
97 年度 FY 2008	—	12,539,866	—	12,539,866
98 年度 FY 2009	—	8,274,576	—	8,274,576
99 年度 FY 2010	—	4,999,750	—	4,999,750
100 年度 FY 2011	—	2,226,710	—	2,226,710
101 年度 FY 2012	—	1,200,781	—	1,200,781
102 年度 FY 2013	—	745,571	—	745,571
1 月 Jan.	—	892,986	—	892,986
2 月 Feb.	—	—	—	—
3 月 Mar.	—	—	—	—
4 月 Apr.	—	—	—	—
5 月 May	—	-33,654	—	-33,654
6 月 June	—	-113,761	—	-113,761
7 月 July	—	1,390	1,390	—
8 月 Aug.	—	-1,390	-1,390	—
9 月 Sep.	—	—	—	—
10 月 Oct.	—	—	—	—
11 月 Nov.	—	—	—	—
12 月 Dec.	—	—	—	—

Table 2. Budget Amount, Audited Amount and Actual Collection
in Recent Years (Cont. 9)

(II) Revenues from Taxes

9. Education Surtax

(1)Subtotal

Unit : N.T.\$1

實徵數 Actual Collection			退還以前年度 歲入款 Tax Income Returned (4)	實徵淨額 Net Actual Collection (1-4=5)	實徵淨額 占預算數 % Net Actual Collection /Budge Amount (5/A)×100
合計 Total (2+3=1)	本年度 Current FY (2)	以前年度 Previous FY (3)			
1,921,591	5,444	1,916,147	1,515	1,920,076	--
2,913,698	28,543	2,885,155	9,414	2,904,284	--
1,303,967	—	1,303,967	38,877	1,265,090	--
1,386,379	—	1,386,379	12,263	1,374,116	--
755,593	—	755,593	—	755,593	--
355,000	—	355,000	1,231,783	- 876,783	--
668,897	—	668,897	10,629,176	- 9,960,279	--
344,041	—	344,041	341,047	2,994	--
304,361	—	304,361	40,452	263,909	--
73,510	—	73,510	—	73,510	--
—	—	—	—	—	--
22,112	—	22,112	—	22,112	--
—	—	—	—	—	--
—	—	—	—	—	--
—	—	—	—	—	--
51,398	—	51,398	—	51,398	--
—	—	—	—	—	--
—	—	—	—	—	--
—	—	—	—	—	--
—	—	—	—	—	--
—	—	—	—	—	--

表 2 歷年各項稅捐預算數、查定數與實徵數 (續10)

(二)稅課收入

9. 九年國民義務教育附徵教育經費

單位：新臺幣元

(2)房屋稅

年度(月)別 Fiscal Year (Month)	預算數 Budget Amount (A)	查定數 Audited Amount		
		合計 Total	本年度 Current FY	以前年度 Previous FY
93 年度 FY 2004	—	26,823,992	5,019	26,818,973
94 年度 FY 2005	—	22,852,091	28,543	22,823,548
95 年度 FY 2006	—	18,474,872	—	18,474,872
96 年度 FY 2007	—	13,738,671	—	13,738,671
97 年度 FY 2008	—	10,259,504	—	10,259,504
98 年度 FY 2009	—	7,692,721	—	7,692,721
99 年度 FY 2010	—	4,894,676	—	4,894,676
100 年度 FY 2011	—	2,213,603	—	2,213,603
101 年度 FY 2012	—	1,200,781	—	1,200,781
102 年度 FY 2013	—	745,571	—	745,571
1 月 Jan.	—	892,986	—	892,986
2 月 Feb.	—	—	—	—
3 月 Mar.	—	—	—	—
4 月 Apr.	—	—	—	—
5 月 May	—	- 33,654	—	- 33,654
6 月 June	—	- 113,761	—	- 113,761
7 月 July	—	1,390	1,390	—
8 月 Aug.	—	- 1,390	- 1,390	—
9 月 Sep.	—	—	—	—
10 月 Oct.	—	—	—	—
11 月 Nov.	—	—	—	—
12 月 Dec.	—	—	—	—

Table 2. Budget Amount, Audited Amount and Actual Collection
in Recent Years (Cont. 10)

(II) Revenues from Taxes

9. Education Surtax

(2) House Tax

Unit : N.T.\$1

實徵數 Actual Collection			退還以前年度 歲入款 Tax Income Returned (4)	實徵淨額 Net Actual Collection (1-4=5)	實徵淨額 占預算數 % Net Actual Collection /Budge Amount (5/A)×100
合計 Total (2+3=1)	本年度 Current FY (2)	以前年度 Previous FY (3)			
1,754,868	5,019	1,749,849	1,515	1,753,353	--
2,831,690	28,543	2,803,147	9,414	2,822,276	--
1,251,965	—	1,251,965	38,877	1,213,088	--
1,307,026	—	1,307,026	11,356	1,295,670	--
735,622	—	735,622	—	735,622	--
343,930	—	343,930	1,231,783	-887,853	--
664,650	—	664,650	10,629,176	-9,964,526	--
344,041	—	344,041	341,047	2,994	--
304,361	—	304,361	40,452	263,909	--
73,510	—	73,510	—	73,510	--
—	—	—	—	—	--
22,112	—	22,112	—	22,112	--
—	—	—	—	—	--
—	—	—	—	—	--
—	—	—	—	—	--
51,398	—	51,398	—	51,398	--
—	—	—	—	—	--
—	—	—	—	—	--
—	—	—	—	—	--
—	—	—	—	—	--
—	—	—	—	—	--

表 2 歷年各項稅捐預算數、查定數與實徵數 (續11)

(二)稅課收入

9. 九年國民義務教育附徵教育經費

單位：新臺幣元

(3)娛樂稅

年度(月)別 Fiscal Year (Month)	預算數 Budget Amount (A)	查定數 Audited Amount		
		合計 Total	本年度 Current FY	以前年度 Previous FY
93 年度 FY 2004	—	4,992,235	425	4,991,810
94 年度 FY 2005	—	3,923,032	—	3,923,032
95 年度 FY 2006	—	3,464,675	—	3,464,675
96 年度 FY 2007	—	2,791,555	—	2,791,555
97 年度 FY 2008	—	2,280,362	—	2,280,362
98 年度 FY 2009	—	581,855	—	581,855
99 年度 FY 2010	—	105,074	—	105,074
100 年度 FY 2011	—	13,107	—	13,107
101 年度 FY 2012	—	—	—	—
102 年度 FY 2013	—	—	—	—
1 月 Jan.	—	—	—	—
2 月 Feb.	—	—	—	—
3 月 Mar.	—	—	—	—
4 月 Apr.	—	—	—	—
5 月 May	—	—	—	—
6 月 June	—	—	—	—
7 月 July	—	—	—	—
8 月 Aug.	—	—	—	—
9 月 Sep.	—	—	—	—
10 月 Oct.	—	—	—	—
11 月 Nov.	—	—	—	—
12 月 Dec.	—	—	—	—

表 2 歷年各項稅捐預算數、查定數與實徵數 (續12)

(三)工程受益費

單位：新臺幣元

年度(月)別 Fiscal Year (Month)	預算數 Budget Amount (A)	查定數 Audited Amount		
		合計 Total	本年度 Current FY	以前年度 Previous FY
93 年度 FY 2004	—	3,879,407	—	3,879,407
94 年度 FY 2005	—	73,882	—	73,882
95 年度 FY 2006	—	45,351	—	45,351
96 年度 FY 2007	—	116,439	—	116,439
97 年度 FY 2008	—	—	—	—
98 年度 FY 2009	—	—	—	—
99 年度 FY 2010	—	—	—	—
100 年度 FY 2011	—	42,197	—	42,197
101 年度 FY 2012	—	—	—	—
102 年度 FY 2013	—	—	—	—
1 月 Jan.	—	—	—	—
2 月 Feb.	—	—	—	—
3 月 Mar.	—	—	—	—
4 月 Apr.	—	—	—	—
5 月 May	—	—	—	—
6 月 June	—	—	—	—
7 月 July	—	—	—	—
8 月 Aug.	—	—	—	—
9 月 Sep.	—	—	—	—
10 月 Oct.	—	—	—	—
11 月 Nov.	—	—	—	—
12 月 Dec.	—	—	—	—

表 2 歷年各項稅捐預算數、查定數與實徵數 (續13)

(四)罰鍰收入

單位：新臺幣元

年度(月)別 Fiscal Year (Month)	預算數 Budget Amount (A)	查定數 Audited Amount		
		合計 Total	本年度 Current FY	以前年度 Previous FY
93 年度 FY 2004	123,021,000	489,809,033	117,152,766	372,656,267
94 年度 FY 2005	188,000,000	464,605,562	118,648,479	345,957,083
95 年度 FY 2006	183,000,000	437,452,233	72,706,354	364,745,879
96 年度 FY 2007	183,000,000	442,108,236	126,466,198	315,642,038
97 年度 FY 2008	204,000,000	475,339,022	162,206,174	313,132,848
98 年度 FY 2009	201,000,000	494,714,768	157,439,459	337,275,309
99 年度 FY 2010	155,000,000	547,722,155	204,193,586	343,528,569
100 年度 FY 2011	154,000,000	563,414,313	133,481,505	429,932,808
101 年度 FY 2012	135,000,000	496,099,434	98,656,201	397,443,233
102 年度 FY 2013	131,000,000	493,644,600	101,500,747	392,143,853
1 月 Jan.	15,383,000	376,844,439	9,053,213	367,791,226
2 月 Feb.	11,196,000	8,085,075	4,984,312	3,100,763
3 月 Mar.	11,278,000	4,297,110	2,513,377	1,783,733
4 月 Apr.	10,589,000	12,099,835	5,045,929	7,053,906
5 月 May	12,842,000	13,009,320	12,108,096	901,224
6 月 June	8,370,000	14,545,031	12,080,723	2,464,308
7 月 July	11,048,000	12,686,089	9,410,637	3,275,452
8 月 Aug.	6,389,000	4,791,499	4,948,867	-157,368
9 月 Sep.	10,629,000	10,891,064	10,004,652	886,412
10 月 Oct.	7,286,000	13,775,273	12,831,026	944,247
11 月 Nov.	9,700,000	6,552,955	4,013,392	2,539,563
12 月 Dec.	16,290,000	16,066,910	14,506,523	1,560,387

Table 2. Budget Amount, Audited Amount and Actual Collection
in Recent Years (Cont. 13)
(IV) Punitive Fine Revenue

Unit : N.T.\$1

實徵數 Actual Collection			退還以前年度 歲入款 Tax Income Returned (4)	實徵淨額 Net Actual Collection (1-4=5)	實徵淨額 占預算數 % Net Actual Collection /Budge Amount (5/A)×100
合計 Total (2+3=1)	本年度 Current FY (2)	以前年度 Previous FY (3)			
227,139,704	93,764,480	133,375,224	47,722,560	179,417,144	145.8
223,858,767	67,694,444	156,164,323	13,162,067	210,696,700	112.1
230,087,703	53,836,140	176,251,563	4,777,848	225,309,855	123.1
191,975,376	58,776,047	133,199,329	6,943,632	185,031,744	101.1
191,887,419	64,189,183	127,698,236	8,921,665	182,965,754	89.7
199,652,733	58,490,467	141,162,266	47,262,251	152,390,482	75.8
165,963,949	62,178,322	103,785,627	105,644,011	60,319,938	38.9
188,127,746	59,663,707	128,464,039	27,995,613	160,132,133	104.0
130,740,906	43,159,508	87,581,398	12,973,313	117,767,593	87.2
143,182,097	55,284,547	87,897,550	13,370,440	129,811,657	99.1
8,471,502	338,037	8,133,465	534,034	7,937,468	51.6
12,317,451	5,058,979	7,258,472	168,011	12,149,440	108.5
9,103,167	1,471,639	7,631,528	6,547,890	2,555,277	22.7
12,995,224	1,957,562	11,037,662	147,629	12,847,595	121.3
13,785,766	6,664,470	7,121,296	248,114	13,537,652	105.4
11,700,535	4,154,461	7,546,074	236,725	11,463,810	137.0
11,671,372	4,096,069	7,575,303	71,555	11,599,817	105.0
8,047,986	2,420,503	5,627,483	272,003	7,775,983	121.7
10,774,068	4,236,656	6,537,412	282,946	10,491,122	98.7
11,809,577	5,270,420	6,539,157	4,431,271	7,378,306	101.3
10,322,995	4,187,684	6,135,311	124,881	10,198,114	105.1
22,182,454	15,428,067	6,754,387	305,381	21,877,073	134.3

表 2 歷年各項稅捐預算數、查定數與實徵數 (續14完)

(五)規費收入

單位：新臺幣元

監證費

年度(月)別 Fiscal Year (Month)	預算數 Budget Amount (A)	查定數 Audited Amount		
		合計 Total	本年度 Current FY	以前年度 Previous FY
93 年度 FY 2004	—	593	—	593
94 年度 FY 2005	—	—	—	—
95 年度 FY 2006	—	—	—	—
96 年度 FY 2007	—	4,097	—	4,097
97 年度 FY 2008	—	—	—	—
98 年度 FY 2009	—	149,080	—	149,080
99 年度 FY 2010	—	—	—	—
100 年度 FY 2011	—	—	—	—
101 年度 FY 2012	—	—	—	—
102 年度 FY 2013	—	—	—	—
1 月 Jan.	—	—	—	—
2 月 Feb.	—	—	—	—
3 月 Mar.	—	—	—	—
4 月 Apr.	—	—	—	—
5 月 May	—	—	—	—
6 月 June	—	—	—	—
7 月 July	—	—	—	—
8 月 Aug.	—	—	—	—
9 月 Sep.	—	—	—	—
10 月 Oct.	—	—	—	—
11 月 Nov.	—	—	—	—
12 月 Dec.	—	—	—	—

表 3 各項稅捐納庫數

(一)歷年別

單位：新臺幣元

年 度 (月) 別 Fiscal Year (Month)	實 徵 數 ① Actual Collection	納 庫 數	
		合 計 Total	國庫 Nation Treasury
93 年 度 FY 2004	58,546,075,931	58,545,599,695	—
94 年 度 FY 2005	60,821,499,933	60,821,258,612	—
95 年 度 FY 2006 ③	59,935,082,828	59,934,140,690	—
96 年 度 FY 2007 ④	62,211,212,658	62,211,212,658	—
97 年 度 FY 2008 ⑤	57,349,343,608	57,349,343,608	—
98 年 度 FY 2009	57,906,303,509	57,906,010,169	—
99 年 度 FY 2010 ⑥	61,412,898,686	61,412,898,686	—
100 年 度 FY 2011	62,364,742,945	62,364,742,945	—
101 年 度 FY 2012 ⑦	62,751,393,789	62,751,393,789	—
102 年 度 FY 2013 ⑧	66,673,882,137	66,673,882,137	—
1 月 Jan.	3,365,291,978	2,875,131,816	—
2 月 Feb.	1,525,296,538	1,817,951,955	—
3 月 Mar.	3,023,001,497	2,817,836,427	—
4 月 Apr.	5,460,528,985	4,475,095,732	—
5 月 May	11,879,768,049	9,593,819,437	—
6 月 June	5,886,879,706	9,279,783,723	—
7 月 July	3,034,437,851	3,048,694,370	—
8 月 Aug.	1,679,072,603	1,729,784,264	—
9 月 Sep.	2,142,374,007	2,137,650,900	—
10 月 Oct.	2,185,512,109	1,862,482,287	—
11 月 Nov.	14,100,766,331	7,801,717,554	—
12 月 Dec.	12,390,952,483	19,233,933,672	—

資料來源：依據徵課會計報告編製。

附 註：①自99年度起實徵數未含實物抵繳稅款(以遞延收入入帳)。

②年度之未納庫數係歷年實物抵繳稅款累計數。

③以前年度實物抵繳23,648元於95年度變賣納庫。

④以前年度實物抵繳26,763元於96年度變賣納庫。

Table 3. Taxation Forwarded to Treasury

(I) Fiscal Year

Unit : N.T.\$1

Pay to Treasury			未納庫數 Unpay to ② Treasury
中央統籌專戶 Distribution of Central Gov't	重建基金庫 Reconstruction Fund	市庫 The Municipal Treasury	
—	—	58,545,599,695	57,754,280
—	—	60,821,258,612	57,995,601
—	—	59,934,140,690	58,914,091
—	—	62,211,212,658	58,887,328
—	—	57,349,343,608	58,886,859
—	—	57,906,010,169	59,180,199
—	—	61,412,898,686	59,145,876
—	—	62,364,742,945	59,145,876
—	—	62,751,393,789	59,489,460
—	—	66,673,882,137	59,451,157
—	—	2,875,131,816	490,160,162
—	—	1,817,951,955	197,504,745
—	—	2,817,836,427	402,669,815
—	—	4,475,095,732	1,388,103,068
—	—	9,593,819,437	3,674,051,680
—	—	9,279,783,723	281,147,663
—	—	3,048,694,370	266,891,144
—	—	1,729,784,264	216,179,483
—	—	2,137,650,900	220,902,590
—	—	1,862,482,287	543,932,412
—	—	7,801,717,554	6,842,981,189
—	—	19,233,933,672	—

⑤ 以前年度實物抵繳469元於97年度變賣納庫。

⑥ 以前年度實物抵繳34,323元於99年度變賣納庫。

⑦ 101年度未納庫數含實物抵繳343,584元。

⑧ 以前年度實物抵繳38,303元於102年度變賣納庫。

表 3 各項稅捐納庫數(續)

(二)稅目別
102年度

單位：新臺幣元

稅目別 Item of Tax	實徵數 Actual Collection	納庫數 Pay to Treasury			
		合計 Total	國庫 The Nation Treasury	中央統籌專戶 Distribution of Central Gov't	重建基金庫 Reconstruction Fund
總計 Grand Total	66,673,882,137	66,673,882,137	—	—	—
地價稅 Land Value Tax	22,143,481,947	22,143,481,947	—	—	—
土地增值稅 Land value Increment Tax	19,103,840,213	19,103,840,213	—	—	—
房屋稅 House Tax	11,997,380,436	11,997,380,436	—	—	—
使用牌照稅 Vehicle License Tax	6,955,441,436	6,955,441,436	—	—	—
契稅 Deed Tax	1,718,308,296	1,718,308,296	—	—	—
印花稅 Stamp Tax	4,383,222,779	4,383,222,779	—	—	—
娛樂稅 Amusement Tax	228,951,423	228,951,423	—	—	—
教育經費 Education Surtax	73,510	73,510	—	—	—
工程受益費 Construction Benefit Fee	—	—	—	—	—
罰鍰收入 Punitive Fine Revenue	143,182,097	143,182,097	—	—	—
規費收入 Fees Revenue	—	—	—	—	—

Table 3. Taxation Forwarded to Treasury (Cont.)

(II) Item of Tax				
FY 2013				
Unit : N.T.\$1				
退還以前年度歲入款 Tax Income Returned				
市 庫 The Municipal Treasury	合 計 Total	國 庫 The Nation Treasury	中央統籌專戶 Distribution of Central Gov't	市 庫 The Municipal Treasury
66,673,882,137	233,351,037	—	—	233,351,037
22,143,481,947	57,150,883	—	—	57,150,883
19,103,840,213	131,046,359	—	—	131,046,359
11,997,380,436	21,333,121	—	—	21,333,121
6,955,441,436	5,347,283	—	—	5,347,283
1,718,308,296	3,357,047	—	—	3,357,047
4,383,222,779	1,721,851	—	—	1,721,851
228,951,423	24,053	—	—	24,053
73,510	—	—	—	—
—	—	—	—	—
143,182,097	13,370,440	—	—	13,370,440
—	—	—	—	—

表 4 歷年各項稅捐實徵淨額及指數

基 比：100年度=100

環 比：上年度=100

分 配 比：各年度總計=100

單位：新臺幣千元

稅 目 別 Item of Tax	93年度 FY2004	94年度 FY2005			95年度	
	實徵淨額 Net Actual Collection	實徵淨額 Net Actual Collection	指數 Index		分配比 Shares	實徵淨額 Net Actual Collection
			基 比 Fixed Index	環 比 Link Index		
總 計 Grand Total	58,044,127	60,543,000	97.4	104.3	100.0	59,559,142
稅 課 收 入 Revenues from Taxes	57,860,878	60,332,240	97.3	104.3	99.7	59,333,787
地 價 稅 Land Value Tax	17,105,907	17,557,773	85.6	102.6	29.0	17,900,813
土地增值稅 Land Value Increment Tax	19,249,448	20,254,961	116.4	105.2	33.5	18,608,089
房 屋 稅 House Tax	9,393,066	9,890,207	91.0	105.3	16.3	9,997,706
使用牌照稅 Vehicle License Tax	6,344,755	6,471,516	96.2	102.0	10.7	6,442,749
契 稅 Deed Tax	2,209,697	2,328,136	116.2	105.4	3.9	2,389,860
印 花 稅 Stamp Tax	3,329,220	3,584,655	84.4	107.7	5.9	3,749,305
娛 樂 稅 Amusement Tax	226,865	242,088	99.3	106.7	0.4	244,000
教育經費 Education Surtax	1,920	2,904	96,800.0	151.3	0.0	1,265
工程受益費 Construction Benefit Fee	3,862	74	176.2	1.9	0.0	45
罰 鍰 收 入 Punitive Fine Revenue	179,417	210,697	131.6	117.4	0.3	225,310
規 費 收 入 Fees Revenue	-30	- 11	--	--	- 0.0	--
契稅監證費 Fees	-30	- 11	--	--	- 0.0	--

資料來源：依據徵課會計報告編製。

Table 4. Net Amount Remitted and Index in Recent Years

Fixed Index:FY2011=100

Link Index>Last Year=100

Shares:Total=100

Unit:N.T.\$1,000

FY 2006			96年度 FY2007				97年度 FY2008				
指數 Index		分配比 Shares	實徵淨額 Net Actual Collection	指數 Index		分配比 Shares	實徵淨額 Net Actual Collection	指數 Index		分配比 Shares	
基 比 Fixed Index	環 比 Link Index			基 比 Fixed Index	環 比 Link Index			基 比 Fixed Index	環 比 Link Index		
95.8	98.4	100.0	61,880,951	99.6	103.9	100.0	56,753,478	91.3	91.7	100.0	
95.7	98.3	99.6	61,695,799	99.5	104.0	99.7	56,570,534	91.2	91.7	99.7	
87.3	102.0	30.1	19,468,697	94.9	108.8	31.5	19,188,394	93.6	98.6	33.8	
106.9	91.9	31.2	19,037,783	109.4	102.3	30.8	13,549,409	77.8	71.2	23.9	
92.0	101.1	16.8	10,091,271	92.9	100.9	16.3	10,140,620	93.3	100.5	17.9	
95.8	99.6	10.8	6,562,146	97.6	101.9	10.6	6,536,438	97.2	99.6	11.5	
119.2	102.7	4.0	2,468,967	123.2	103.3	4.0	2,369,087	118.2	96.0	4.2	
88.3	104.6	6.3	3,868,318	91.1	103.2	6.2	4,573,341	107.7	118.2	8.0	
100.1	100.8	0.4	197,243	80.9	80.8	0.3	212,489	87.2	107.7	0.4	
42,166.7	43.6	0.0	1,374	45,800.0	108.6	0.0	756	25,200.0	55.0	0.0	
107.1	60.8	0.0	116	276.2	257.8	0.0	- 22	--	--	- 0.0	
140.7	106.9	0.4	185,032	115.5	82.1	0.3	182,966	114.3	98.9	0.3	
--	--	--	4	--	--	0.0	--	--	--	--	
--	--	--	4	--	--	0.0	--	--	--	--	

表 4 歷年各項稅捐實徵淨額及指數 (續)

基 比：100年度=100

環 比：上年度=100

分配 比：各年度總計=100

單位：新臺幣千元

稅目別 Item of Tax	98年度 FY2009				99年度 FY2010				100年度
	實徵淨額 Net Actual Collection	指數 Index		分配比 Shares	實徵淨額 Net Actual Collection	指數 Index		分配比 Shares	實徵淨額 Net Actual Collection
		基比 Fixed Index	環比 Link Index			基比 Fixed Index	環比 Link Index		
總 計 Grand Total	57,498,023	92.5	101.3	100.0	60,905,235	98.0	105.9	100.0	62,159,442
稅 課 收 入 Revenues from Taxes	57,345,484	92.5	101.4	99.7	60,844,915	98.1	106.1	99.9	61,999,268
地 價 稅 Land Value Tax	18,702,394	91.2	97.5	32.5	20,291,042	99.0	108.5	33.3	20,505,209
土地增值稅 Land Value Increment Tax	15,413,916	88.5	113.8	26.8	16,884,890	97.0	109.5	27.7	17,407,266
房 屋 稅 House Tax	10,295,486	94.8	101.5	17.9	10,500,537	96.6	102.0	17.3	10,865,123
使用牌照稅 Vehicle License Tax	6,462,009	96.1	98.9	11.2	6,542,070	97.3	101.2	10.7	6,726,767
契 稅 Deed Tax	2,357,002	117.6	99.5	4.1	2,327,147	116.1	98.7	3.8	2,004,331
印 花 稅 Stamp Tax	3,905,531	92.0	85.4	6.8	4,082,316	96.1	104.5	6.7	4,246,762
娛 樂 稅 Amusement Tax	210,023	86.1	98.8	0.4	226,873	93.1	108.0	0.4	243,807
教育經費 Education Surtax	- 877	--	--	-0.0	- 9,960	--	--	-0.0	3
工程受益費 Construction Benefit Fee	--	--	--	--	--	--	--	--	42
罰 鍰 收 入 Punitive Fine Revenue	152,390	95.2	83.3	0.3	60,320	37.7	39.6	0.1	160,132
規 費 收 入 Fees Revenue	149	--	--	0.0	--	--	--	--	--
契稅監證費 Fees	149	--	--	0.0	--	--	--	--	--

表 5 本處各項稅捐稽徵成本①②

Table 5. Cost of Tax Levying ①②

年度及稅目別 Fiscal Year & Item of Tax	實徵淨額 (千元) Net Actual Collection (N.T.\$1000) (1)	實支經費 (元) Expense (N.T.\$1) (2)	每千元成本 (元) Cost of \$1,000 (2)/(1)
93 年度 FY 2004	57,860,878	931,864,861	16.1053
94 年度 FY 2005	60,332,240	896,828,571	14.8648
95 年度 FY 2006	59,333,787	914,484,276	15.4125
96 年度 FY 2007	61,695,799	898,794,972	14.5682
97 年度 FY 2008	56,570,534	894,798,178	15.8174
98 年度 FY 2009	57,345,484	894,489,263	15.5983
99 年度 FY 2010	60,844,915	899,839,885	14.7891
100 年度 FY 2011	61,999,268	888,513,303	14.3310
101 年度 FY 2012	62,189,138	893,122,419	14.3614
102 年度 FY 2013	66,310,719	904,340,532	13.6379
地價稅 Land Value Tax	22,086,331	261,534,316	11.8415
土地增值稅 Land Value Increment Tax	18,972,794	202,533,473	10.6749
房屋稅 House Tax	11,976,121	215,434,268	17.9887
使用牌照稅 Vehicle License Tax	6,950,094	110,784,457	15.9400
契稅 Deed Tax	1,714,951	48,896,723	28.5120
印花稅 Stamp Tax	4,381,501	34,732,913	7.9272
娛樂稅 Amusement Tax	228,927	30,424,382	132.8999

資料來源：根據本處會計室資料編製。

附註：①依據財政部賦稅署擬訂之各稅稽徵成本計算方式一致性規定說明書之編算原則核計。

②房屋稅與娛樂稅實徵淨額含九年國民義務教育附徵教育經費。

參、稅源及其他

III . Tax Sources and Others

表 6 地價稅稅源

單位 { 面積：公頃
金額：新臺幣千元

年別及稅地種類別 Year & Classification		戶數 No. of House	筆數 Plots
97	年 2008	822,864	1,760,008
98	年 2009	834,400	1,782,383
99	年 2010	843,247	1,814,594
100	年 2011	852,009	1,843,386
101	年 2012	860,251	1,868,226
102	年 2013	867,911	1,917,506
公	有 Public	346	132,020
一般土地	Regular Land	328	119,145
自用住宅用地	Self-use Residence Land	9	173
工礦業等用地	Specific Business Land	—	237
公共設施保留地	Land Reserved for Public Facilities	9	12,465
私	有 Private	867,565	1,785,486
一般土地	Regular Land	377,780	822,406
第一級	Level 1	374,197	781,218
第二級	Level 2	3,053	27,777
第三級	Level 3	272	2,811
第四級	Level 4	95	1,427
第五級	Level 5	41	721
第六級	Level 6	122	8,452
自用住宅用地	Self-use Residence Land	487,183	892,475
都市土地	Urban Land	487,183	892,475
非都市土地	Non-Urban Land	—	—
工礦業等用地	Specific Business Land	31	1,713
公共設施保留地	Land Reserved for Public Facilities	2,571	68,892

資料來源：根據本處財產稅科資料編製。

Table 6. Sources of Land Value Tax

課 稅 面 積 Taxed Area	課 稅 地 價 Taxed Land Value	Uni
		{ Area : Hectare Amount : N.T.\$1,000
		地 價 稅 額 Land Value Tax
4,861.1691	1,906,412,830	18,691,962
4,835.7439	1,911,687,078	18,425,014
4,959.2458	2,091,696,127	20,056,339
4,915.9018	2,087,899,910	20,131,896
5,034.7634	2,096,510,787	20,339,436
4,951.7003	2,247,409,509	22,164,453
323.4543	178,607,411	1,722,533
296.0262	168,855,023	1,688,550
21.2819	6,686,735	13,373
0.6700	553,830	5,538
5.4761	2,511,823	15,071
4,628.2459	2,068,802,098	20,441,921
2,388.1638	1,063,839,334	18,027,414
1,560.4597	649,492,419	6,494,913
389.7400	159,051,274	1,988,975
85.2286	42,489,264	712,391
48.8724	29,296,227	637,473
27.4679	18,003,722	476,767
276.3949	165,506,429	7,716,895
2,048.1644	946,950,400	1,893,872
2,048.1644	946,950,400	1,893,872
—	—	—
92.9047	43,140,249	431,402
99.0128	14,872,115	89,232

表 7 土地增值稅稅源

單位 { 面積：公頃
金額：新臺幣千元

年度及稅率別 Fiscal Year & Rate of Tax	筆數 Plots	面積 Area	移轉現值 Present Value of Transfer	調整後原地價 Originally Declared Value After Adjustment	
93 年 度 FY2004	130,387	812.4215	489,425,596	262,757,015	
94 年 度 FY2005	132,593	683.7837	465,562,997	286,530,211	
95 年 度 FY2006	137,910	610.5693	452,335,486	311,509,340	
96 年 度 FY2007	133,614	598.8314	449,354,075	309,302,178	
97 年 度 FY2008	134,635	513.1119	418,194,495	299,218,322	
98 年 度 FY2009	124,589	415.3626	411,747,421	286,607,620	
99 年 度 FY2010	138,294	509.0032	440,310,323	305,753,138	
100 年 度 FY2011	127,170	436.1678	382,853,776	252,580,246	
101 年 度 FY2012	102,169	334.1813	321,992,197	193,999,469	
102 年 度 FY2013	105,050	324.0251	353,553,228	200,038,953	
自用住宅用地 稅率10%	Self-use Residence Land (Rate 10%)	11,727	25.6969	50,989,187	22,303,626
一般用地	Regular Land	59,857	113.7159	200,969,626	125,567,461
稅率20%	Rate 20%	49,672	83.7593	157,623,025	118,641,263
稅率30%	Rate 30%	2,174	5.1572	7,038,408	3,054,604
稅率40%	Rate 40%	7,982	24.7994	36,308,193	3,871,594
其他	Others	29	0.0000	—	—
免稅地	Exempt Land	33,466	184.6123	101,594,415	52,167,866
公有土地	Public Land	746	2.6957	9,998,701	427,135
私有土地	Private Land	32,720	181.9166	91,595,714	51,740,731

資料來源：根據本處財產稅科資料編製。

附註：①102年度含免稅地相關資料。

Table 7. Sources of Land Value Increment Tax

Unit { Area : Hectare Amount : N.T.\$1,000					
改良土地費用 Land Improvement Cost	漲價總數額 Cross Amount of Land Value Increment	查定稅額① Assessment Tax	增繳地價稅① Supplemental Payment of Land Value Tax	減徵稅額① Reduction	應納稅額 Tax Payable
1,229,670	225,438,911	32,789,855	1,495,956	1,420,352	29,873,547
1,675,612	177,357,174	25,564,553	1,111,589	1,262,153	23,190,811
4,241,536	136,584,610	20,497,584	908,315	1,319,686	18,269,583
2,264,726	137,787,171	22,179,717	946,091	1,002,950	20,230,676
1,266,847	117,709,326	16,157,946	611,854	428,479	15,117,613
2,003,969	123,135,832	17,240,793	684,454	709,141	15,847,198
1,429,814	133,127,371	19,232,065	773,734	861,337	17,596,994
659,623	129,613,907	18,695,238	727,894	646,878	17,320,466
261,858	127,730,870	17,406,309	705,764	550,475	16,150,070
335,014	157,067,733	38,289,539	817,989	441,657	20,368,311
3,637	28,681,925	2,868,187	130,859	25,490	2,706,153
321,354	75,080,811	18,713,122	623,271	405,346	17,662,158
3,530	38,978,232	7,799,951	181,259	41,313	7,566,868
303	3,983,501	881,942	38,553	40,515	798,474
317,521	32,119,078	10,025,041	403,459	323,518	9,290,628
—	—	6,188	—	—	6,188
10,023	53,304,997	16,708,230	63,859	10,821	—
—	9,589,834	3,149,927	7,262	—	—
10,023	43,715,163	13,558,303	56,597	10,821	—

表 8 房 屋 稅 稅 源

單位 { 面積：平方公尺
金額：新臺幣千元

年度別、構造及使用別 Fiscal Year & Structure & Use	合計 Total		
	戶數 Number of House	面積 Area	現值 Value
98 年 度 FY2009	1,066,524	171,184,561	715,945,585
99 年 度 FY2010	1,080,152	176,383,620	741,065,141
100 年 度 FY2011	1,089,541	178,554,255	753,492,124
101 年 度 FY2012	1,097,581	180,692,750	832,912,306
102 年 度 FY2013	1,105,979	184,555,387	846,250,956
住 家 用 Residence	775,441	83,395,748	332,945,144
營 業 用 Business	142,088	31,760,318	227,574,342
非住家非營業用 Non-Residence、Non-Business	50,803	15,727,352	89,149,668
全部免稅及部份免稅 Exempt House	137,647	53,671,969	196,581,803
鋼 骨 混 凝 土 造 Steeled Concrete	30,811	21,147,312	224,461,604
住 家 用 Residence	14,986	2,480,401	44,763,321
營 業 用 Business	8,253	7,025,291	92,909,416
非住家非營業用 Non-Residence、Non-Business	5,644	3,976,121	34,563,567
全部免稅及部份免稅 Exempt House	1,928	7,665,499	52,225,300
鋼 筋 混 凝 土 及 預 鑄 造 Concrete&Reinforced Prefabricated	929,974	145,844,140	600,322,445
住 家 用 Residence	704,317	72,727,272	277,420,750
營 業 用 Business	112,190	21,708,924	130,452,657
非住家非營業用 Non-Residence、Non-Business	42,848	11,292,830	53,942,638
全部免稅及部份免稅 Exempt House	70,619	40,115,114	138,506,401
鋼 筋 混 凝 土 加 強 磚 造 Ferroconcrete Brick	101,210	12,935,465	17,035,877
住 家 用 Residence	49,089	7,002,668	9,356,001
營 業 用 Business	14,531	2,083,387	3,152,221
非住家非營業用 Non-Residence、Non-Business	1,577	302,080	442,664
全部免稅及部份免稅 Exempt House	36,013	3,547,332	4,084,992
鋼 鐵 造 Metal	6,479	1,413,296	1,795,454
住 家 用 Residence	2,595	429,480	576,186
營 業 用 Business	1,889	538,983	690,642
非住家非營業用 Non-Residence、Non-Business	269	79,173	103,840
全部免稅及部份免稅 Exempt House	1,726	365,660	424,788

資料來源：根據本處財產稅科資料編製。

Table 8. Sources of House Tax

Unit { Area : m²
Amount : N.T.\$1,000

公有 Public			私有 Private		
戶數 Number of House	面積 Area	現值 Value	戶數 Number of House	面積 Area	現值 Value
25,199	21,669,145	85,409,345	1,041,325	149,515,416	630,536,240
26,422	24,158,745	92,550,508	1,053,730	152,224,875	648,514,633
25,223	23,243,844	92,350,866	1,064,318	155,310,411	661,141,259
25,604	23,768,422	101,179,846	1,071,977	156,924,328	731,732,460
25,082	24,155,256	102,135,487	1,080,897	160,400,131	744,115,469
5,658	611,579	3,318,093	769,783	82,784,170	329,627,051
1,211	1,375,016	8,831,798	140,877	30,385,301	218,742,544
570	1,589,209	5,135,494	50,233	14,138,143	84,014,174
17,643	20,579,452	84,850,102	120,004	33,092,517	111,731,701
674	4,194,647	32,653,293	30,137	16,952,665	191,808,312
114	33,792	512,775	14,872	2,446,609	44,250,546
160	417,592	3,722,811	8,093	6,607,699	89,186,605
65	329,540	1,479,225	5,579	3,646,581	33,084,343
335	3,413,723	26,938,482	1,593	4,251,775	25,286,818
17,014	18,600,870	67,841,594	912,960	127,243,271	532,480,851
5,459	564,994	2,787,352	698,858	72,162,278	274,633,398
850	909,934	5,033,282	111,340	20,798,991	125,419,375
479	1,250,512	3,645,670	42,369	10,042,318	50,296,968
10,226	15,875,429	56,375,291	60,393	24,239,685	82,131,110
2,277	700,768	1,003,286	98,933	12,234,697	16,032,591
57	8,824	13,156	49,032	6,993,843	9,342,845
93	31,496	57,673	14,438	2,051,891	3,094,548
20	5,346	6,384	1,557	296,734	436,279
2,107	655,102	926,073	33,906	2,892,229	3,158,919
188	132,750	212,346	6,291	1,280,546	1,583,108
2	239	328	2,593	429,241	575,857
19	3,526	4,396	1,870	535,457	686,246
1	630	840	268	78,543	103,000
166	128,355	206,782	1,560	237,305	218,005

表 8 房 屋 稅 稅 源 (續)

單位 { 面積：平方公尺
金額：新臺幣千元

年度別、構造及使用別 Fiscal Year & Structure & Use	合 計 Total		
	戶 數 Number of House	面 積 Area	現 值 Value
磚 石 造 Brick	26,418	2,479,319	2,215,959
住 家 用 Residence	4,166	702,581	776,810
營 業 用 Business	3,886	316,087	303,520
非 住 家 非 營 業 用 Non-Residence · Non-Business	379	68,100	91,153
全部免稅及部份免稅 Exempt House	17,987	1,392,551	1,044,475
咭 咕 石 造 Lo-Ko Stone	381	26,391	15,898
住 家 用 Residence	10	2,311	1,933
營 業 用 Business	75	3,075	2,251
非 住 家 非 營 業 用 Non-Residence · Non-Business	7	888	553
全部免稅及部份免稅 Exempt House	289	20,117	11,161
卵 石 混 凝 土 造 Concrete & Pebble	40	3,924	3,398
住 家 用 Residence	10	1,744	1,747
營 業 用 Business	1	200	97
非 住 家 非 營 業 用 Non-Residence · Non-Business	2	169	169
全部免稅及部份免稅 Exempt House	27	1,811	1,384
木 造 Wood	9,238	602,857	394,473
住 家 用 Residence	264	48,422	47,848
營 業 用 Business	1,244	79,631	62,986
非 住 家 非 營 業 用 Non-Residence · Non-Business	77	7,991	5,083
全部免稅及部份免稅 Exempt House	7,653	466,813	278,555
土 磚 造 Earthen Brick	1,226	92,702	4,921
住 家 用 Residence	3	754	495
營 業 用 Business	8	1,246	82
非 住 家 非 營 業 用 Non-Residence · Non-Business	—	—	—
全部免稅及部份免稅 Exempt House	1,215	90,702	4,344
竹 造 Bamboo	202	9,980	927
住 家 用 Residence	1	115	55
營 業 用 Business	11	3,494	470
非 住 家 非 營 業 用 Non-Residence · Non-Business	—	—	—
全部免稅及部份免稅 Exempt House	190	6,372	402

Table 8. Sources of House Tax (Cont.)

 Unit {
 Area : m²
 Amount : N.T.\$1,000

公有 Public			私有 Private		
戶數 Number of House	面積 Area	現值 Value	戶數 Number of House	面積 Area	現值 Value
2,310	316,517	294,030	24,108	2,162,802	1,921,929
19	2,569	3,261	4,147	700,012	773,549
48	9,428	11,752	3,838	306,659	291,768
4	3,151	3,358	375	64,949	87,795
2,239	301,369	275,658	15,748	1,091,182	768,817
24	1,328	779	357	25,063	15,119
—	—	—	10	2,311	1,933
—	—	—	75	3,075	2,251
—	—	—	7	888	553
24	1,328	779	265	18,789	10,382
1	136	58	39	3,788	3,340
—	—	—	10	1,744	1,747
—	—	—	1	200	97
—	—	—	2	169	169
1	136	58	26	1,675	1,327
2,575	207,410	130,072	6,663	395,447	264,400
7	1,160	1,221	257	47,262	46,627
41	3,041	1,885	1,203	76,590	61,101
1	29	17	76	7,962	5,067
2,526	203,180	126,950	5,127	263,633	151,606
14	595	19	1,212	92,107	4,902
—	—	—	3	754	495
—	—	—	8	1,246	82
—	—	—	—	—	—
14	595	19	1,201	90,107	4,325
5	235	9	197	9,745	917
—	—	—	1	115	55
—	—	—	11	3,494	470
—	—	—	—	—	—
5	235	9	185	6,137	393

表 9 使用牌照稅稅源 ①

單位：件數

年 度 (月) 別 Fiscal Year (Month)			合 計 Grand Total		小客車② Sedan	
			應 稅 Taxable	免 稅 Exempt	應 稅 Taxable	免 稅 Exempt
93	年 度	FY2004	778,892	13,965	696,942	12,605
94	年 度	FY2005	808,646	12,591	720,200	11,999
95	年 度	FY2006	735,342	17,237	642,890	16,577
96	年 度	FY2007	742,355	16,855	650,569	16,391
97	年 度	FY2008	746,054	16,177	644,206	15,696
98	年 度	FY2009	740,831	17,330	638,594	16,937
99	年 度	FY2010	760,699	17,301	654,886	16,779
100	年 度	FY2011	785,192	14,007	675,588	13,311
101	年 度	FY2012	807,716	17,117	693,474	16,256
102	年 度	FY2013	830,876	17,321	711,151	16,698
1	月	Jan.	16,321	1,581	14,212	1,562
2	月	Feb.	11,788	1,021	10,259	981
3	月	Mar.	37,941	1,758	32,770	1,709
4	月	Apr.	341,881	1,684	299,538	1,649
5	月	May	263,086	1,439	229,247	1,413
6	月	June	9,955	1,314	8,369	1,300
7	月	July	14,955	1,596	12,241	1,524
8	月	Aug.	12,955	1,339	10,800	1,249
9	月	Sep.	9,008	1,249	6,992	1,196
10	月	Oct.	31,642	1,390	22,836	1,365
11	月	Nov.	71,552	1,398	55,439	1,267
12	月	Dec.	9,792	1,552	8,448	1,483

資料來源：根據本處機會稅科資料編製。

附 註：①本表臨時牌照、試車牌照及外賓車輛不予計列。

②小客車、大客車、貨車中均分為自用與營業用，自用全年開徵1次。營業用分兩期開徵，表列數字均依照年度結束累計數填列。

Table 9. Sources of Vehicle License Tax ①

Unit : Case

大客車② Bus		貨車② Truck		機器腳踏車 Motorcycle	
應 稅 Taxable	免 稅 Exempt	應 稅 Taxable	免 稅 Exempt	應 稅 Taxable	免 稅 Exempt
6,533	1,073	71,653	252	3,764	35
6,424	299	77,151	285	4,871	8
6,418	398	80,153	246	5,881	16
6,639	216	84,277	241	870	7
6,582	257	87,197	220	8,069	4
6,682	213	86,878	168	8,677	12
7,535	318	88,809	171	9,469	33
7,961	520	90,583	154	11,060	22
8,237	643	92,732	197	13,273	21
8,485	423	93,267	164	17,973	36
132	16	1,558	2	419	1
79	32	1,044	6	406	2
201	40	3,421	9	1,549	—
1,951	25	33,193	6	7,199	4
1,779	22	28,375	3	3,685	1
106	13	595	1	885	—
136	68	1,452	4	1,126	—
164	70	1,326	18	665	2
234	6	1,096	34	686	13
2,026	13	6,231	11	549	1
1,538	108	14,200	18	375	5
139	10	776	52	429	7

表 10 契 稅 稅 源

金額單位：新臺幣千元

年 度 (月) 別 Fiscal Year (Month)			合 計 Total		買 賣 契 Sale		典 權 契 Mortgage	
			件 數 Cases	契 價 Deed Value	件 數 Cases	契 價 Deed Value	件 數 Cases	契 價 Deed Value
93	年 度	FY2004	74,604	41,478,262	66,304	37,216,205	6	1,930
94	年 度	FY2005	78,805	42,521,645	70,956	39,447,405	2	183
95	年 度	FY2006	79,012	41,555,453	71,997	38,820,971	—	—
96	年 度	FY2007	73,683	41,980,833	65,634	38,907,839	—	—
97	年 度	FY2008	75,310	41,816,490	67,242	38,369,514	—	—
98	年 度	FY2009	74,931	41,053,558	66,802	38,260,775	1	486
99	年 度	FY2010	75,298	40,464,169	66,392	37,287,407	1	0
100	年 度	FY2011	61,336	35,197,097	51,816	31,575,261	1	133
101	年 度	FY2012	51,933	31,062,867	41,217	27,193,643	—	—
102	年 度	FY2013	51,550	29,279,464	41,398	25,134,588	1	513
1	月	Jan.	5,729	3,261,961	3,716	2,734,037	—	—
2	月	Feb.	4,036	2,231,550	2,890	1,750,696	1	513
3	月	Mar.	3,648	2,510,741	2,943	2,214,332	—	—
4	月	Apr.	4,529	2,754,997	3,837	2,374,427	—	—
5	月	May	4,761	2,473,418	4,055	2,233,024	—	—
6	月	June	4,415	2,495,367	3,798	2,244,338	—	—
7	月	July	4,565	3,918,138	3,938	3,745,573	—	—
8	月	Aug.	4,036	1,720,001	3,406	1,542,182	—	—
9	月	Sep.	3,849	1,822,022	3,167	1,519,067	—	—
10	月	Oct.	3,073	987,151	2,557	832,156	—	—
11	月	Nov.	4,691	2,728,245	3,816	1,870,889	—	—
12	月	Dec.	4,218	2,375,873	3,275	2,073,867	—	—

資料來源：根據本處財產稅科資料編製。

附 註：本表件數含應稅與免稅。

Table 10. Sources of Deed Tax

Unit : N.T.\$1,000

交換契 Exchange		贈與契 Donation		分割契 Division		占有契 Staking	
件數 Cases	契價 Deed Value	件數 Cases	契價 Deed Value	件數 Cases	契價 Deed Value	件數 Cases	契價 Deed Value
891	1,281,176	7,054	2,265,958	348	712,349	1	644
938	927,672	6,672	1,891,870	236	254,221	1	294
926	1,019,933	5,912	1,519,979	173	193,656	4	914
1,348	1,345,151	6,613	1,688,921	88	38,922	—	—
1,308	1,306,651	6,590	1,721,469	170	418,856	—	—
1,013	911,399	7,015	1,854,852	100	26,046	—	—
894	815,303	7,914	2,207,685	97	153,774	—	—
1,117	1,120,083	8,350	2,490,558	52	11,062	—	—
1,178	1,079,514	9,474	2,771,281	64	18,429	—	—
864	1,283,123	9,215	2,783,729	72	77,512	—	—
24	12,249	1,978	499,241	11	16,435	—	—
84	48,962	1,050	395,477	11	35,902	—	—
110	89,095	590	201,449	5	5,866	—	—
157	190,459	535	190,111	—	—	—	—
40	46,964	661	188,544	5	4,886	—	—
77	55,443	530	185,553	10	10,034	—	—
26	16,887	601	155,678	—	—	—	—
15	4,009	615	173,810	—	—	—	—
118	149,305	560	153,520	4	129	—	—
16	21,111	498	133,714	2	170	—	—
147	594,607	725	262,578	3	171	—	—
50	54,032	872	244,054	21	3,920	—	—

表 11 印花稅稅源 ①

單位：新臺幣千元

年 度 (月) 別 Fiscal Year (Month)	合 計① Total	出 售 印 花 稅 票 Taxes Stamps	總		
			金融業 Finance	保 險 業 Insurance	傳 播 業 Broadcasting
98 年 度 FY2009	3,890,354	568,107	1,093,360	634,146	2,067
99 年 度 FY2010	4,061,562	565,080	1,138,041	575,952	2,035
100 年 度 FY2011	4,232,189	514,547	1,175,596	616,064	1,978
101 年 度 FY2012	4,466,450	477,820	1,182,223	684,628	1,926
102 年 度 FY2013	4,381,501	448,112	1,223,112	706,812	1,815
1 月 Jan.	619,768	39,783	193,652	112,455	280
2 月 Feb.	84,283	43,633	1	—	—
3 月 Mar.	584,922	21,214	200,854	127,078	282
4 月 Apr.	106,703	29,359	847	—	—
5 月 May	648,269	27,179	208,790	110,273	292
6 月 June	121,034	40,059	0	—	—
7 月 July	654,721	42,598	204,825	119,898	377
8 月 Aug.	127,672	60,111	0	—	—
9 月 Sep.	628,665	41,396	208,265	129,408	301
10 月 Oct.	99,244	31,657	—	0	—
11 月 Nov.	595,694	38,490	205,854	107,702	283
12 月 Dec.	110,526	32,633	23	0	—

資料來源：根據本處機會稅科資料編製。

附 註：①101年以前為本年度實徵數，102年為本年度實徵淨額。

Table 11. Sources of Stamp Tax ①

Unit : N.T.\$1,000

繳				Total Payment	違章補繳 Payment on Tax Evasion
公用事業 Utilities	承攬契據 Construction agreements	財產契據 Real Estate Deed	其他 Others		
19,497	384,248	279,449	909,358	122	
22,504	391,806	330,777	1,035,364	3	
23,682	500,736	315,310	1,084,271	5	
23,304	629,040	283,867	1,183,611	31	
26,789	537,595	324,602	1,112,238	427	
5,625	43,584	37,136	187,246	7	
0	21,762	17,921	965	—	
4,396	41,008	25,273	164,817	—	
—	49,069	26,001	1,426	—	
3,024	71,550	27,357	199,663	142	
—	56,371	23,185	1,418	1	
8,332	50,993	32,476	195,222	—	
—	43,887	22,224	1,450	—	
2,369	37,418	22,730	186,779	—	
—	42,483	23,884	1,220	—	
3,043	45,571	24,904	169,849	—	
—	33,899	41,512	2,182	278	

表 12 娛 樂 稅 稅 源 ①

金額單位：新臺幣元

年 度 (月) 別 Fiscal Year (Month)			合 計 Total		電 影 Movies	
			家 數 Unit	實 徵 稅 額 Net Amount Remitted	家 數 Unit	實 徵 稅 額 Net Amount Remitted
93	年 度	FY2004	1,972	220,654,104	52	42,363,492
94	年 度	FY2005	2,308	242,087,524	44	47,458,117
95	年 度	FY2006	2,037	243,999,753	40	48,012,314
96	年 度	FY2007	1,859	197,243,270	38	46,686,982
97	年 度	FY2008	1,781	212,488,992	37	39,388,243
98	年 度	FY2009	1,718	210,022,962	33	42,732,259
99	年 度	FY2010	1,671	226,872,556	36	52,681,026
100	年 度	FY2011	1,677	243,807,447	36	60,653,547
101	年 度	FY2012	1,624	224,137,868	37	57,768,614
102	年 度	FY2013	1,615	228,927,370	37	61,062,114
1	月	Jan.	1,614	18,345,018	36	5,563,765
2	月	Feb.	1,592	15,504,375	37	3,837,095
3	月	Mar.	1,580	19,349,571	37	5,711,088
4	月	Apr.	1,598	20,128,396	37	4,193,120
5	月	May	1,607	19,850,128	37	5,047,203
6	月	June	1,601	18,573,368	36	5,997,791
7	月	July	1,595	24,046,587	36	6,524,705
8	月	Aug.	1,598	23,880,899	36	7,086,207
9	月	Sep.	1,598	20,641,692	37	5,072,353
10	月	Oct.	1,655	16,979,179	37	3,659,477
11	月	Nov.	1,618	14,178,481	37	3,478,483
12	月	Dec.	1,615	17,449,676	37	4,890,827

資料來源：根據本處機會稅科資料編製。

附 註：①93年以前家數為實徵家數，實徵稅額為本年度實徵數；94年起家數為自動報繳及查定之家數，實徵稅額為實徵淨額。

②其他欄內包括臨時公演及夜總會、戲劇等。

表 12 娛 樂 稅 稅 源 ① (續)

金額單位：新臺幣元

年 度 (月) 別 Fiscal Year (Month)			高爾夫球練習場 Golf		舞廳 (場) Dance Halls		電子遊戲機 Electric Toys	
			家數 Unit	實徵稅額 Net Amount Remitted	家數 Unit	實徵稅額 Net Amount Remitted	家數 Unit	實徵稅額 Net Amount Remitted
93	年 度	FY2004	13	4,930,744	43	22,843,408	362	21,320,140
94	年 度	FY2005	13	5,310,997	46	24,977,469	138	22,193,156
95	年 度	FY2006	13	3,846,895	42	22,974,644	111	9,239,571
96	年 度	FY2007	13	2,407,224	32	17,620,681	86	8,960,627
97	年 度	FY2008	14	-6,539,283	32	15,664,322	78	8,313,668
98	年 度	FY2009	14	3,003,059	27	13,659,294	78	6,683,071
99	年 度	FY2010	14	3,092,520	28	12,137,962	70	6,257,564
100	年 度	FY2011	14	3,510,075	26	10,112,917	68	5,801,330
101	年 度	FY2012	16	3,424,660	21	9,148,763	65	5,721,201
102	年 度	FY2013	19	3,250,593	22	10,243,677	53	5,101,660
1	月	Jan.	16	364,755	21	885,864	66	485,612
2	月	Feb.	16	255,453	22	829,037	66	457,780
3	月	Mar.	16	269,665	22	792,882	64	491,952
4	月	Apr.	16	238,124	22	835,729	64	419,783
5	月	May	16	285,313	22	835,949	64	523,212
6	月	June	16	276,532	22	860,713	61	366,134
7	月	July	16	263,179	22	846,918	61	390,148
8	月	Aug.	16	258,982	22	814,055	60	416,455
9	月	Sep.	16	243,444	22	882,424	59	383,336
10	月	Oct.	16	263,828	22	874,890	57	378,116
11	月	Nov.	18	263,547	22	900,738	56	378,390
12	月	Dec.	19	267,771	22	884,478	53	410,742

Table 12. Sources of Amusement Tax ① (Cont.)

Unit : N.T.\$1

有節目餐飲業 Entertainment Restaurants		MTV等視聽業 MTV Audiovisual Services		其他② Others	
家數 Unit	實徵稅額 Net Amount Remitted	家數 Unit	實徵稅額 Net Amount Remitted	家數 Unit	實徵稅額 Net Amount Remitted
35	2,920,937	1,173	99,985,972	188	23,692,076
43	3,328,523	1,376	108,439,846	545	26,072,117
41	5,183,399	1,330	103,915,313	369	46,955,592
37	5,440,419	1,262	77,130,597	387	37,001,453
29	5,442,995	1,243	93,469,130	347	56,552,132
31	3,977,099	1,184	77,448,808	350	62,397,510
37	3,747,894	1,143	76,850,740	342	71,990,208
36	4,246,597	1,158	77,062,565	338	82,286,593
37	4,329,054	1,102	73,187,045	345	70,486,111
41	3,879,719	1,065	71,752,214	377	73,564,973
39	337,329	1,096	6,317,301	339	4,384,357
40	443,884	1,099	5,815,695	311	3,859,396
38	463,392	1,096	6,774,706	306	4,839,851
39	302,322	1,099	5,613,580	320	8,519,703
39	290,214	1,089	5,744,774	339	7,117,428
39	269,115	1,093	5,324,526	333	5,472,522
38	309,774	1,082	6,677,102	339	9,028,726
40	252,413	1,089	5,831,170	334	9,215,582
42	272,682	1,078	6,122,880	343	7,658,538
40	265,265	1,080	5,770,188	402	5,761,380
40	361,366	1,085	6,078,041	359	2,711,881
41	311,963	1,065	5,682,251	377	4,995,609

表 13 違章漏稅案件處理及財務罰鍰執行情形表

單位 { 件數：件
金額：新臺幣千元

年度及稅目別 Fiscal Year & Item of Tax	受理情形 No. of Cases Accepted			本期審理情形	
	合計 Total	上期未 結件數 Unclosed Cases of Last Term	本期受 理件數 Cases Accepted in this Term	依法免 議件數 Cases Not Indictable	依法免 罰件數 Fine Free Cases
93 年 度 FY2004	2,921	8	2,913	18	122
94 年 度 FY2005	5,082	347	4,735	68	100
95 年 度 FY2006	3,909	61	3,848	80	105
96 年 度 FY2007	5,408	232	5,176	199	73
97 年 度 FY2008	6,799	143	6,656	368	36
98 年 度 FY2009	7,725	37	7,688	398	186
99 年 度 FY2010	14,445	147	14,298	576	2,976
100 年 度 FY2011	7,936	260	7,676	542	1,034
101 年 度 FY2012	6,042	72	5,970	382	726
102 年 度 FY2013	5,635	44	5,591	289	387
地 價 稅 Land Value Tax	5	—	5	2	—
土 地 增 值 稅 Land Value Increment Tax	2	—	2	1	—
房 屋 稅 House Tax	—	—	—	—	—
使 用 牌 照 稅 Vehicle License Tax	5,606	43	5,563	285	381
契 稅 Deed Tax	—	—	—	—	—
印 花 稅 Stamp Tax	5	—	5	—	1
娛 樂 稅 Amusement Tax	17	1	16	1	5

資料來源：根據本處稅務管理科資料編製。

Table 13. The Management of Cases of Tax Evasion Against Law
and Execution Status of Fine

Unit: { Case
N.T.\$1,000

Cases Interrogated in This Term			本期繳納及移送情形 Cases of Find Paid and Transferred to Law Court in This Term					
處罰 Cases Fined		未結 件數 Cases Unclosed	合計 Total		自行繳納 Paid		移送執行 Transferred to Law Court	
件數 Cases	金額 Amount		件數 Cases	金額 Amount	件數 Cases	金額 Amount	件數 Cases	金額 Amount
2,434	55,723	347	3,024	90,848	2,752	75,900	272	14,948
4,853	98,832	61	3,342	82,690	3,303	78,801	39	3,889
3,492	59,977	232	3,867	82,339	3,053	53,577	814	28,762
4,993	110,999	143	5,351	93,588	3,070	36,461	2,281	57,127
6,358	187,241	37	6,649	141,108	3,567	56,162	3,082	84,946
6,994	142,501	147	9,527	177,289	2,991	56,029	6,536	121,260
10,633	230,263	260	13,542	253,119	4,703	42,138	8,839	210,981
6,288	101,053	72	13,282	213,703	4,897	31,559	8,385	182,144
4,890	81,560	44	11,727	178,053	4,092	23,740	7,635	154,313
4,898	68,455	61	11,152	162,532	3,543	27,326	7,609	135,206
3	219	—	4	3,988	4	3,988	—	—
1	683	—	2	683	2	683	—	—
—	—	—	1	101	1	101	—	—
4,885	64,946	55	11,121	154,639	3,516	19,494	7,605	135,145
—	—	—	—	—	—	—	—	—
4	1,947	—	7	3,030	7	3,030	—	—
5	660	6	17	91	13	30	4	61

表 13 違章漏稅案件處理及財務罰鍰執行情形表 (續)

單位 { 件數：件
金額：新臺幣千元

年度及稅目別 Fiscal Year & Item of Tax	更正註銷案件 Case of Revising or Cancelling		截至本期末繳未移送 Cases of Not Transferred of Fined		本 期	
					合 計 Total	
	件 數 Cases	金 額 Amount	件 數 Cases	金 額 Amount	件 數 Cases	金 額 Amount
93 年 度 FY2004	- 318	24,577	3,288	898,675	182	5,898
94 年 度 FY2005	- 295	15,072	5,208	903,209	186	8,609
95 年 度 FY2006	- 224	26,333	5,239	859,127	329	11,284
96 年 度 FY2007	- 305	10,162	5,904	886,003	1,106	31,902
97 年 度 FY2008	- 908	30,551	8,284	943,501	2,576	59,340
98 年 度 FY2009	-1,399	24,282	10,086	977,070	4,341	118,649
99 年 度 FY2010	-1,745	15,011	13,650	1,056,004	6,478	148,069
100 年 度 FY2011	-1,890	38,177	11,325	265,486	9,270	219,195
101 年 度 FY2012	-3,553	1,865	12,785	284,823	6,560	150,690
102 年 度 FY2013	6	33,485	11,583	264,921	6,996	136,684
地 價 稅 Land Value Tax	-2	-3,833	1	64	—	—
土 地 增 值 稅 Land Value Increment Tax	- 1	25	1	10,895	—	25
房 屋 稅 House Tax	-1	-101	—	—	—	—
使 用 牌 照 稅 Vehicle License Tax	22	37,182	11,577	251,631	6,994	136,412
契 稅 Deed Tax	—	—	—	—	—	—
印 花 稅 Stamp Tax	- 1	-505	1	1,981	—	73
娛 樂 稅 Amusement Tax	- 11	717	3	350	2	174

Table 13. The Management of Cases of Tax Evasion Against Law and Execution Status of Fine (Cont.)

Unit: { Case
N.T.\$1,000

執行情形 Cases Executed in This Term						截至本期未執行案件 Cases Unexecuted	
移送繳納 Fined Paid		發給執行憑證 Giving Executive Evidence		移送駁回或撤回 Cases of Withdrawn or Rejected			
件數 Cases	金額 Amount	件數 Cases	金額 Amount	件數 Cases	金額 Amount	件數 Cases	金額 Amount
95	3,717	74	1,837	13	344	1,230	574,436
72	5,145	84	2,335	30	1,129	1,083	569,716
147	6,671	175	4,364	7	249	1,568	587,194
388	12,275	675	17,291	43	2,336	2,743	612,419
813	17,424	1,695	39,871	68	2,045	3,249	638,025
1,405	26,010	2,829	90,581	107	2,058	5,444	640,636
1,750	31,268	4,584	113,901	144	2,900	7,805	703,548
2,118	41,503	7,019	173,858	133	3,834	5,866	180,815
1,816	32,995	4,616	114,427	128	3,268	6,941	184,438
1,938	29,024	4,976	105,960	82	1,700	7,554	182,960
—	—	—	—	—	—	—	—
—	25	—	—	—	—	1	10,895
—	—	—	—	—	—	—	—
1,937	28,901	4,975	105,811	82	1,700	7,543	152,241
—	—	—	—	—	—	—	—
—	73	—	—	—	—	6	19,761
1	25	1	149	—	—	4	63

表 14 各項稅捐滯納案件移送執行情形

金額單位：新臺幣元

年度及稅目別 Fiscal Year & Item of Tax	移送執行數 ^① Executed cases		執行徵起數(1) Executive Levied Tax		掣發債權憑證數(2) Giving Executive Evidence	
	件數 Cases	金額 Amount	件數 Cases	金額 Amount	件數 Cases	金額 Amount
93 年度 FY2004	79,553	1,393,535,195	36,486	756,379,529	16,963	147,329,015
94 年度 FY2005	51,283	1,595,546,632	32,601	588,246,111	23,519	167,858,366
95 年度 FY2006	81,754	1,671,258,452	44,204	1,082,993,724	36,292	240,778,668
96 年度 FY2007	82,875	1,058,039,055	46,559	827,587,893	61,579	497,154,171
97 年度 FY2008	76,381	1,024,567,477	39,497	611,348,255	50,078	439,371,016
98 年度 FY2009	86,642	1,070,882,804	38,327	667,009,679	51,666	481,404,542
99 年度 FY2010	80,769	842,479,642	35,215	573,963,337	54,967	843,341,510
100 年度 FY2011	59,383	727,698,688	32,371	714,712,214	53,687	823,659,132
101 年度 FY2012	55,501	546,330,038	26,548	438,195,809	25,761	262,966,626
102 年度 FY2013	46,641	420,820,836	26,114	331,664,615	23,141	176,463,048
地價稅 Land Value Tax	11,441	129,785,437	8,253	116,241,276	4,134	33,215,097
土地增值稅 Land Value Increment Tax	3	1,279,616	3	5,020,444	3	1,247,326
房屋稅 House Tax	7,238	42,014,832	5,478	50,226,069	1,796	17,333,606
使用牌照稅 Vehicle License Tax	25,044	184,645,584	11,716	98,317,811	15,761	100,039,933
契稅 Deed Tax	22	322,234	10	73,979	6	113,220
印花稅 Stamp Tax	—	—	—	—	—	—
娛樂稅 Amusement Tax	2,893	8,532,557	654	2,947,940	1,441	3,166,565
罰鍰 ^② Punitive Fune Revenue	—	54,240,576	—	58,837,096	—	21,347,301

資料來源：根據本處稅務管理科資料編製。

附註：①包括以前年度移送未執行結轉數。

②罰鍰係指本稅以外之短估金、滯(怠)報金、滯納金及加計利息等之合計數，為附加稅，故不計件數。

③101年度以前係指結案數。

Table 14. The Status of Delayed Case Transferred to Execution

Unit : N.T.\$1

撤退案數(3)		稅捐處清理數③(1+2+3=4)		移送尚未執行數	
Cases of Withdrawn		Closed Cases		Unexecuted Cases	
件數 Cases	金額 Amount	件數 Cases	金額 Amount	件數 Cases	金額 Amount
2,145	97,238,093	55,594	1,000,946,637	171,224	3,701,233,044
4,248	282,299,009	60,368	1,038,403,486	151,141	3,993,496,359
4,074	176,829,888	84,570	1,500,602,280	144,239	3,996,599,528
3,946	101,388,745	112,084	1,426,130,809	111,010	3,564,275,012
2,338	104,810,618	91,913	1,155,529,889	92,189	3,380,106,899
1,977	35,843,492	91,970	1,184,257,713	83,718	3,209,836,714
1,851	24,838,280	92,033	1,442,143,127	70,335	2,560,047,010
933	15,260,562	86,991	1,553,631,908	41,370	1,603,167,185
1,017	14,761,965	53,326	715,924,400	42,845	1,395,183,086
520	6,656,743	49,775	514,784,406	4,307	151,801,244
205	3,465,475	12,592	152,921,848	511	67,419,033
1	380,590	7	6,648,360	1	1,045,120
67	355,388	7,341	67,915,063	599	39,154,060
243	1,894,645	27,720	200,252,389	3,082	21,904,763
—	—	16	187,199	1	2,659
—	—	—	—	2	214,652
4	8,428	2,099	6,122,933	111	908,013
—	552,217	—	80,736,614	—	21,152,944

表 15 查(核)定開徵數及未徵數情形

單位 { 件數：件
金額：新臺幣千元

一. 本年度

年度及稅目別 Fiscal Year & Item of Tax	查(核)定開徵數 Opening Collection for Assessed(Verified) (1)		實徵數 Tax Collected (2)		減免註銷數 Cancelled (3)		逾徵收 期限數 Overdue (4)	
	件數 Cases	金額 Amount	件數 Cases	金額 Amount	件數 Cases	金額 Amount	件數 Cases	金額 Amount
98 年度 FY2009	2,937,340	57,788,816	2,832,920	54,984,201	24,194	1,145,170	—	—
99 年度 FY2010	3,025,499	62,977,206	2,903,255	59,320,680	44,195	1,964,206	1	2
100 年度 FY2011	3,008,150	63,464,263	2,912,650	59,970,637	29,434	2,144,176	—	—
101 年度 FY2012	3,041,661	64,291,613	2,950,791	60,881,995	23,796	1,568,405	—	—
102 年度 FY2013	3,061,761	68,463,016	2,974,908	64,981,290	25,022	2,069,634	—	—
地價稅 Land Value Tax	878,657	22,971,651	844,504	21,644,234	1,442	720,381	—	—
土地增值稅 Land Value Increment Tax	74,897	20,126,597	71,319	18,728,768	2,476	911,588	—	—
房屋稅 House Tax	1,030,494	12,059,370	1,021,326	11,884,759	2,145	78,226	—	—
使用牌照稅 Vehicle License Tax	889,200	7,191,727	863,202	6,866,251	13,319	235,889	—	—
契稅 Deed Tax	53,368	1,782,783	51,506	1,699,547	1,353	67,422	—	—
印花稅 Stamp Tax	109,122	4,010,690	102,025	3,904,651	3,214	38,651	—	—
娛樂稅 Amusement Tax	20,471	232,765	18,929	225,358	538	3,989	—	—
罰鍰 Fine	5,552	87,434	2,097	27,722	535	13,488	—	—

資料來源：根據本處稅務管理科資料編製。

附註：1.本表以開徵始日為統計基礎。

2.實徵數之件數及金額未包含實徵當查定部分。

Table 15. The Management of Opening Collection for Assessed (Verified) and of Tax Not Collected

Unit: { Case
N.T.\$1,000

1. Current Year

逾核課期限數 Excess Assessment (5)		未徵數餘額 Balance of Tax Not Collected					
		合計 Total (6)=(1)-(2)-(3)-(4)-(5)		繳款書未送達 未徵數 Have Not Been Served the Payment Notice		未逾限繳日 未徵數 Have Not Exceeded the Deadline of Payment	
件數 Cases	金額 Amount	件數 Cases	金額 Amount	件數 Cases	金額 Amount	件數 Cases	金額 Amount
18	506	80,208	1,658,939	31,549	549,377	24,395	694,328
100	839	77,948	1,691,479	31,294	606,350	21,096	615,821
14	55	66,052	1,349,395	28,618	487,570	16,925	501,801
15	49	67,059	1,841,163	29,703	881,553	19,519	561,446
13	58	61,818	1,412,034	28,370	668,134	15,015	430,539
10	49	32,701	606,988	26,654	326,619	5,120	170,910
—	—	1,102	486,240	417	334,992	680	150,874
2	2	7,021	96,384	705	2,903	1,913	8,202
1	7	12,678	89,580	242	1,134	2,693	14,151
—	—	509	15,814	61	1,240	442	14,485
—	—	3,883	67,389	93	698	3,789	66,549
—	—	1,004	3,417	191	484	195	1,156
—	—	2,920	46,223	7	65	183	4,212

表 15 查(核)定開徵數及未徵數情形 (續1)

單位 { 件數：件
金額：新臺幣千元

一.本年度

年度及稅目別 Fiscal Year & Item of Tax	未徵數餘額							
	行政救濟 未徵數 Administrative Remedies		分期繳納 未徵數 Pay by Stages		特殊原因 未徵數 Special Reason		欠	
							小計	
	件數 Cases	金額 Amount	件數 Cases	金額 Amount	件數 Cases	金額 Amount	件數 Cases	金額 Amount
98年度 FY2009	177	47,956	1	228	162	130	23,924	366,921
99年度 FY2010	385	100,132	—	—	943	191	24,230	368,986
100年度 FY2011	138	28,466	—	—	462	81	19,909	331,478
101年度 FY2012	199	154,138	—	—	187	97	17,451	243,929
102年度 FY2013	96	70,784	—	—	232	124	18,105	242,454
地價稅 Land Value Tax	51	5,212	—	—	14	3	862	104,244
土地增值稅 Land Value Increment Tax	5	374	—	—	—	—	—	—
房屋稅 House Tax	35	63,016	—	—	122	25	4,246	22,238
使用牌照稅 Vehicle License Tax	—	—	—	—	92	95	9,651	74,200
契稅 Deed Tax	—	—	—	—	—	—	6	89
印花稅 Stamp Tax	1	142	—	—	—	—	—	—
娛樂稅 Amusement Tax	—	—	—	—	4	1	614	1,776
罰鍰 Fine	4	2,041	—	—	—	—	2,726	39,906

Table 15. The Management of Opening Collection for Assessed (Verified) and of Tax Not Collected (Cont.1)

Unit: $\left\{ \begin{array}{l} \text{Case} \\ \text{N.T. \$1,000} \end{array} \right.$

1. Current Year							
Balance of Tax Not Collected							
稅		數		Pending Tax Arrears			
送達未逾滯納期 Service of Notice Has Not Exceeded Delinquency Period		移送執行未結 Transferred to Law Court Not Yet Closed		執行憑證數 Executive Evidence		其他 Others	
件數 Cases	金額 Amount	件數 Cases	金額 Amount	件數 Cases	金額 Amount	件數 Cases	金額 Amount
2,392	115,391	14,874	153,142	760	7,473	5,898	90,915
3,381	30,033	14,261	170,109	2,144	24,500	4,444	144,343
2,379	38,893	11,643	108,743	1,897	16,956	3,990	166,886
2,896	26,988	10,106	93,600	824	7,616	3,625	115,725
2,021	16,523	11,911	104,187	603	5,041	3,570	116,703
294	5,549	175	1,401	—	—	393	97,294
—	—	—	—	—	—	—	—
580	2,091	2,174	13,922	21	85	1,471	6,141
859	6,304	7,144	56,836	310	1,704	1,338	9,356
1	3	5	86	—	—	—	—
—	—	—	—	—	—	—	—
123	381	331	1,126	77	99	83	170
164	2,194	2,082	30,816	195	3,154	285	3,742

表 15 查(核)定開徵數及未徵數情形 (續2)

單位 { 件數：件
金額：新臺幣千元

二. 以前年度

年度及稅目別 Fiscal Year & Item of Tax	查(核)定開徵數①		實徵數		減免註銷數		逾徵收 期限數	
	Opening Collection for Assessed(Verified)		Tax Collected		Cancelled		Overdue	
	(1)		(2)		(3)		(4)	
	件數 Cases	金額 Amount	件數 Cases	金額 Amount	件數 Cases	金額 Amount	件數 Cases	金額 Amount
98 年度 FY2009	247,442	5,940,217	93,329	2,228,577	3,983	72,532	16,641	205,543
99 年度 FY2010	235,711	4,934,146	98,006	1,424,320	1,372	227,162	19,741	406,871
100 年度 FY2011	220,787	4,341,814	93,336	1,752,666	6,370	113,053	17,745	388,801
101 年度 FY2012	184,058	3,393,966	76,631	1,306,722	1,214	61,911	17,482	204,789
102 年度 FY2013	168,974	3,016,747	76,703	1,146,773	478	75,169	13,596	117,944
地價稅 Land Value Tax	56,796	1,044,816	37,506	499,248	66	-19,370	1,871	18,218
土地增值稅 Land Value Increment Tax	1,231	884,007	1,042	375,072	135	85,040	—	—
房屋稅 House Tax	16,595	270,650	9,624	112,621	-42	-1,405	829	10,779
使用牌照稅 Vehicle License Tax	68,016	377,914	20,166	78,388	-76	-666	8,905	57,462
契稅 Deed Tax	662	21,832	587	18,761	52	2,238	4	43
印花稅 Stamp Tax	3,644	37,459	3,432	30,460	209	6,784	—	—
娛樂稅 Amusement Tax	5,057	15,031	962	3,593	-13	-198	757	2,366
罰鍰 Fine	16,973	365,038	3,384	28,628	147	2,747	1,230	29,076

資料來源：根據本處稅務管理科資料編製。

附註：①係原開徵始日在上年度12月31日以前之查(核)定開徵稅款，未逾徵收期間而仍未徵起者。

Table 15. The Management of Opening Collection for Assessed (Verified) and of Tax Not Collected (Cont.2)

Unit: $\begin{cases} \text{Case} \\ \text{N.T.}\$1,000 \end{cases}$

逾核課期限數 Excess Assessment (5)		2. Previous Year 未徵數餘額 Balance of Tax Not Collected					
		合計 Total (6)=(1)-(2)-(3)-(4)-(5)		繳款書未送達 未徵數 Have Not Been Served the Payment Notice		未逾限繳日 未徵數 Have Not Exceeded the Deadline of Payment	
件數 Cases	金額 Amount	件數 Cases	金額 Amount	件數 Cases	金額 Amount	件數 Cases	金額 Amount
1,627	13,855	131,862	3,419,710	1,394	134,308	774	11,154
867	8,942	115,725	2,866,850	1,096	65,705	494	12,452
918	12,931	102,418	2,074,364	994	41,979	318	5,219
691	8,148	88,040	1,812,398	695	25,858	271	9,926
295	4,124	77,902	1,672,737	672	63,134	157	2,656
216	3,140	17,137	543,579	601	9,876	71	1,419
—	—	54	423,895	27	52,819	1	37
6	10	6,178	148,645	7	17	8	291
65	639	38,956	242,091	32	283	72	575
4	25	15	765	1	1	1	237
—	—	3	215	—	—	—	—
—	—	3,351	9,271	—	—	—	—
4	310	12,208	304,277	4	138	4	96

表 15 查(核)定開徵數及未徵數情形 (續3完)

單位 { 件數：件
金額：新臺幣千元

二.以前年度

年度及稅目別 Fiscal Year & Item of Tax	未徵數餘額							
	行政救濟 未徵數 Administrative Remedies		分期繳納 未徵數 Pay by Stages		特殊原因 未徵數 Special Reason		欠 小計 Subtotal	
	件數 Cases	金額 Amount	件數 Cases	金額 Amount	件數 Cases	金額 Amount	件數 Cases	金額 Amount
	98 年度 FY2009	128	102,188	—	—	5,110	13,398	124,456
99 年度 FY2010	188	92,849	—	—	4,676	14,076	109,271	2,681,767
100 年度 FY2011	87	48,158	—	—	5,127	17,124	95,892	1,961,883
101 年度 FY2012	66	107,657	—	—	4,702	20,447	82,306	1,648,510
102 年度 FY2013	206	64,554	—	—	4,512	24,114	72,264	1,517,626
地 價 稅 Land Value Tax	33	33,229	—	—	1,938	22,481	14,467	476,176
土 地 增 值 稅 Land Value Increment Tax	4	8,720	—	—	—	—	22	362,319
房 屋 稅 House Tax	168	22,524	—	—	476	83	5,497	125,548
使 用 牌 照 稅 Vehicle License Tax	—	—	—	—	2,050	1,431	36,781	239,764
契 稅 Deed Tax	—	—	—	—	—	—	13	527
印 花 稅 Stamp Tax	—	—	—	—	1	0	2	215
娛 樂 稅 Amusement Tax	—	—	—	—	36	6	3,314	9,265
罰 鍰 Fine	1	80	—	—	11	114	12,168	303,811

Table 15. The Management of Opening Collection for Assessed (Verified) and of Tax Not Collected (Cont.3 End)

Unit: $\left\{ \begin{array}{l} \text{Case} \\ \text{N.T. \$1,000} \end{array} \right.$

2. Previous Year							
Balance of Tax Not Collected							
稅 數				Pending Tax Arrears			
送達未逾滯納期 Service of Notice Has Not Exceeded Delinquency Period		移送執行未結 Transferred to Law Court Not Yet Closed		執行憑證數 Executive Evidence		其 他 Others	
件 數 Cases	金 額 Amount	件 數 Cases	金 額 Amount	件 數 Cases	金 額 Amount	件 數 Cases	金 額 Amount
281	4,569	45,484	2,424,849	77,847	707,279	844	21,966
146	1,392	31,026	1,889,076	77,567	769,787	532	21,512
115	881	20,254	1,219,373	75,114	723,418	409	18,210
65	361	14,602	1,001,966	67,306	635,422	333	10,761
30	364	14,025	952,511	58,119	563,693	90	1,058
18	273	5,470	393,393	8,917	81,860	62	650
—	—	17	361,019	4	1,270	1	30
—	—	2,840	111,675	2,641	13,537	16	336
11	85	4,016	30,026	32,743	209,611	11	42
—	—	2	359	11	169	—	—
—	—	2	215	—	—	—	—
—	—	215	1,062	3,099	8,203	—	—
1	5	1,463	54,763	10,704	249,043	—	—

表 16 各項稅捐現行稅率表

稅別	課 徵 標 的 及 稅 率			
地 價 稅	地價稅累進起點地價，以本市土地 7 公畝之平均地價為準。但不包括工業用地、礦業用地、農業用地及免稅土地在內。			
	土地類別	級別	累 進 地 價 級 距	稅 率
	私 有 一 般 土 地	1	未超過累進起點地價部分	10 ‰
		2	超過累進起點地價未達 5 倍者，其超過部分	15 ‰
		3	超過累進起點地價 5 倍至 10 倍者，其超過部分	25 ‰
		4	超過累進起點地價 10 倍至 15 倍者，其超過部分	35 ‰
		5	超過累進起點地價 15 倍至 20 倍者，其超過部分	45 ‰
		6	超過累進起點地價 20 倍以上者，其超過部分	55 ‰
	公 有 土 地			10 ‰
	工 業 或 礦 業 用 地			10 ‰
公 共 設 施 保 留 地			6 ‰	
自 用 住 宅 、 國 民 住 宅 及 勞 工 宿 舍 用 地			2 ‰	

表 16 各項稅捐現行稅率表（續 1）

稅別	稅級別	計 算 公 式
土 地 增 值 稅	第一級	應徵稅額＝土地漲價總數額〔超過原規定地價或前次移轉時申報現值（按臺灣地區消費者物價總指數調整後）未達百分之一百者〕×稅率（20%）。
	第二級	<p>應徵稅額＝土地漲價總數額【超過原規定地價或前次移轉時申報現值（按臺灣地區消費者物價總指數調整後）在百分之一百以上未達百分之二百者】×【稅率（30%）－〔（30%－20%）×減徵率〕】－累進差額（按臺灣地區消費者物價總指數調整後之原規定地價或前次移轉現值×A）。</p> <p>註：持有土地年限未超過 20 年者，無減徵，A 為 0.10。 持有土地年限超過 20 年以上者，減徵率為 20%，A 為 0.08。 持有土地年限超過 30 年以上者，減徵率為 30%，A 為 0.07。 持有土地年限超過 40 年以上者，減徵率為 40%，A 為 0.06。</p>
	第三級	<p>應徵稅額＝土地漲價總數額【超過原規定地價或前次移轉時申報現值（按臺灣地區消費者物價總指數調整後）在百分之二百以上者】×【稅率（40%）－〔（40%－20%）×減徵率〕】－累進差額（按臺灣地區消費者物價總指數調整後之原規定地價或前次移轉現值×B）。</p> <p>註：持有土地年限未超過 20 年者，無減徵，B 為 0.30。 持有土地年限超過 20 年以上者，減徵率為 20%，B 為 0.24。 持有土地年限超過 30 年以上者，減徵率為 30%，B 為 0.21。 持有土地年限超過 40 年以上者，減徵率為 40%，B 為 0.18。</p>
自用住宅用地稅率一律 10%		

表 16 各項稅捐現行稅率表 (續 3)

稅別	稅額 (元) 總排量 (立方公分)	車輛 種類	小客車		大客車	貨車	機器腳踏車
			自用	營業	全年	全年	全年
			全年	全年			
使 用 牌 照 稅	150 以下		—	—	—	—	0
	151~ 250		—	—	—	—	800
	251~ 500		1,620	900	—	900	1,620
	501~ 600		2,160	1,260	1,080	1,080	2,160
	601~ 1,200		4,320	2,160	1,800	1,800	4,320
	1,201~ 1,800		7,120	3,060	2,700	2,700	7,120
	1,801~ 2,400		11,230	6,480	3,600	3,600	(1801c.c.以上)11,230
	2,401~ 3,000		15,210	9,900	4,500	4,500	
	3,001~ 3,600	}	28,220	16,380	5,400	5,400	
	3,601~ 4,200				6,300	6,300	
	4,201~ 4,800	}	46,170	24,300	7,200	7,200	
	4,801~ 5,400				8,100	8,100	
	5,401~ 6,000	}	69,690	33,660	9,000	9,000	
	6,001~ 6,600				9,900	9,900	
	6,601~ 7,200	}	117,000	44,460	10,800	10,800	
	7,201~ 7,800				11,700	11,700	
	7,801~ 8,400	}	151,200	56,700	12,600	12,600	
	8,401~ 9,000				13,500	13,500	
9,001~ 9,600	14,400				14,400		
9,601~ 10,200				15,300	15,300		
10,201 以上				16,200	16,200		

臨時牌照	
車別	每日稅額
小客車	41
大客車	23
貨車	22
曳引車	28
機器腳踏車	5

試車牌照	
車別	每日稅額
小客車	414
機器腳踏車	30

附註：1. 曳引車之稅額按貨車稅額加徵 30%。

2. 小客貨兩用車之稅額按自用小客車之稅額課徵。

3. 自用車全年 1 期，營業車全年分上、下 2 期課徵。

表 16 各項稅捐現行稅率表 (續 4)

稅別	車輛種類	稅額 (元)		用途	
		馬達最大馬力		自用	營業
		英制馬力(HP)	公制馬力(PS)		
使 用 牌	完全以電能為動力之電動小客車 (每車乘人座位 9 人以下者)	38 以下	38.6 以下	1,620	900
		38.1~ 56	38.7~ 56.8	2,160	1,260
		56.1~ 83	56.9~ 84.2	4,320	2,160
		83.1~182	84.3~184.7	7,120	3,060
		182.1~262	184.8~265.9	11,230	6,480
		262.1~322	266.0~326.8	15,210	9,900
		322.1~414	326.9~420.2	28,220	16,380
		414.1~469	420.3~476.0	46,170	24,300
		469.1~509	476.1~516.6	69,690	33,660
		509.1 以上	516.7 以上	117,000	44,460
照 稅	完全以電能為動力之電動機器腳踏車	12 以下	12.2 以下		0
		12.1-20	12.3-20.3		800
		20.1-45	20.4-45.7		1,620

附註：臺北市政府於 101 年 2 月 3 日公告，本市完全以電能為動力之電動汽車，自 101 年 1 月 6 日起至 104 年 1 月 5 日止免徵使用牌照稅，期滿後自 104 年 1 月 6 日起恢復課稅。

表 16 各項稅捐現行稅率表 (續 5)

稅別	課 徵 標 的	稅 率
娛 樂 稅	一、舞廳、舞場	25 %
	二、電影	
	1. 外國語片 { (1)市區繁榮地帶	2.5 %
	(2)市區偏僻地帶	1.5 %
	(3)郊區	1 %
	2. 本國語片 { (1)市區繁榮地帶	1 %
	(2)市區偏僻地帶	1 %
	(3)郊區	1 %
	三、高爾夫球練習場	2.5 %
	四、職業性歌唱、舞蹈、馬戲、魔術、技藝表演及夜總會之各種表演。	5 %
五、各種競技比賽及其他提供娛樂設施供人娛樂者。	2.5 %	
六、說書、戲劇、音樂演奏及非職業性歌唱、舞蹈等表演。	1.25 %	
契 稅	一、買賣契按契價	6 %
	二、典權契按契價	4 %
	三、交換契按契價	2 %
	四、贈與契按契價	6 %
	五、分割契按契價	2 %
	六、占有契按契價	6 %

表 17 各項稅捐劃解分配率

102 年度

單位：百分比

稅目	繳庫別	
	國	庫
地價稅	—	100
土地增值稅	—	100
房屋稅	—	100
使用牌照稅	—	100
契稅	—	100
印花稅	—	100
娛樂稅	—	100

表 18 本處各項稅捐稽徵工作流程圖

(一)地 價 稅



表 18 本處各項稅捐稽徵工作流程圖 (續 1)
(二)土地增值稅



表 18 本處各項稅捐稽徵工作流程圖 (續 2)

(三)房 屋 稅

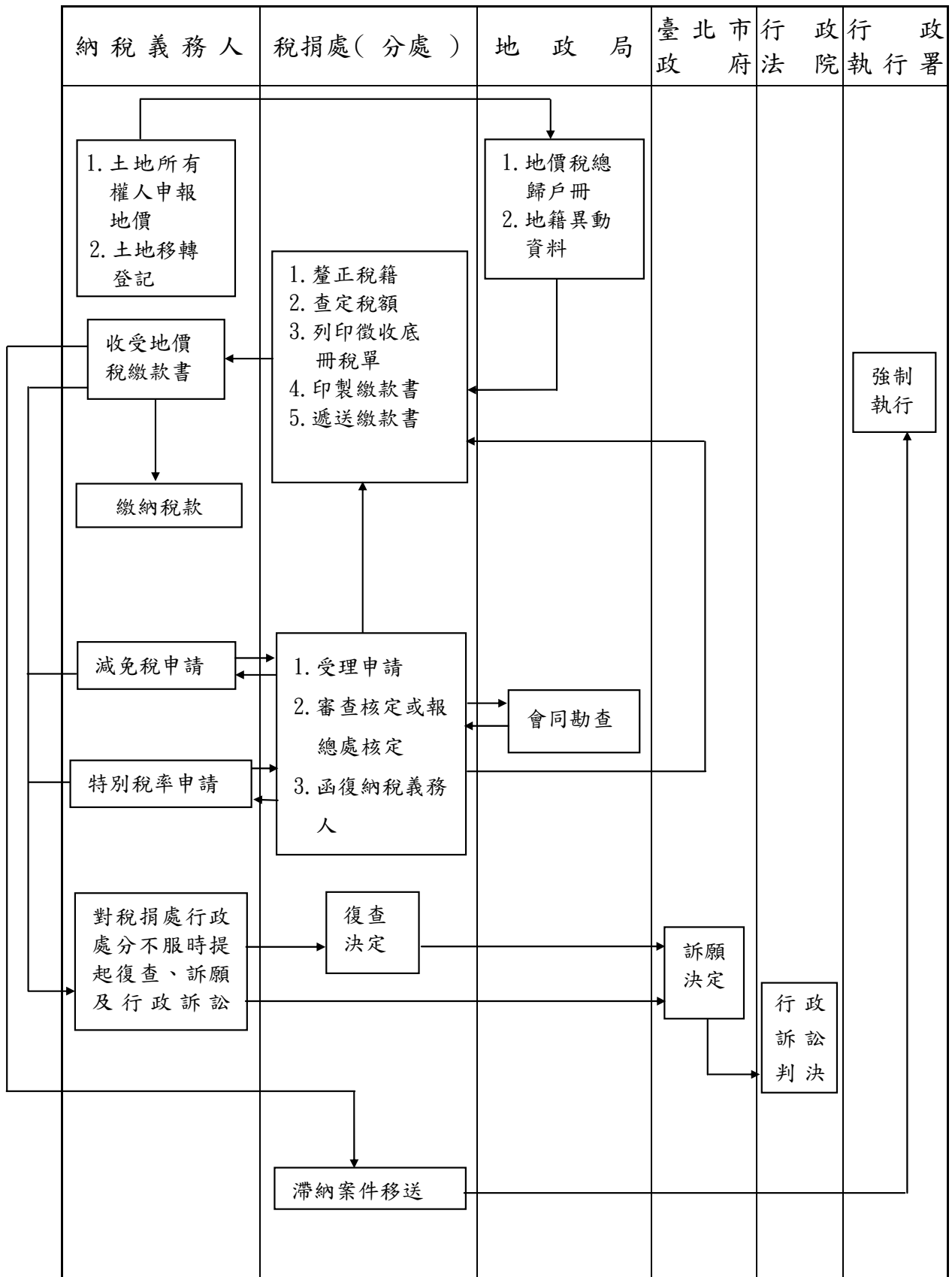

表 18 本處各項稅捐稽徵工作流程圖（續 3）

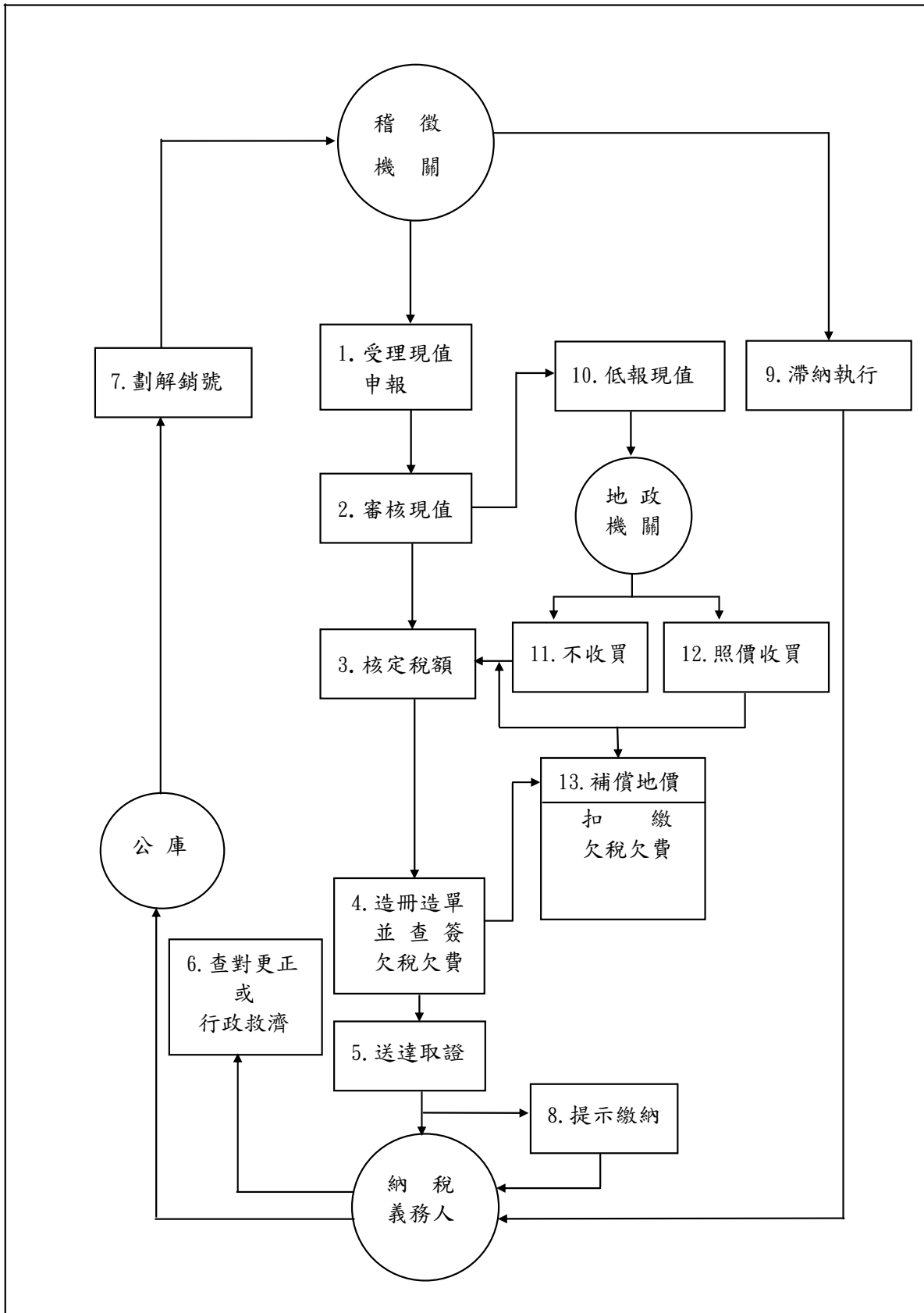
(四)使用牌照稅

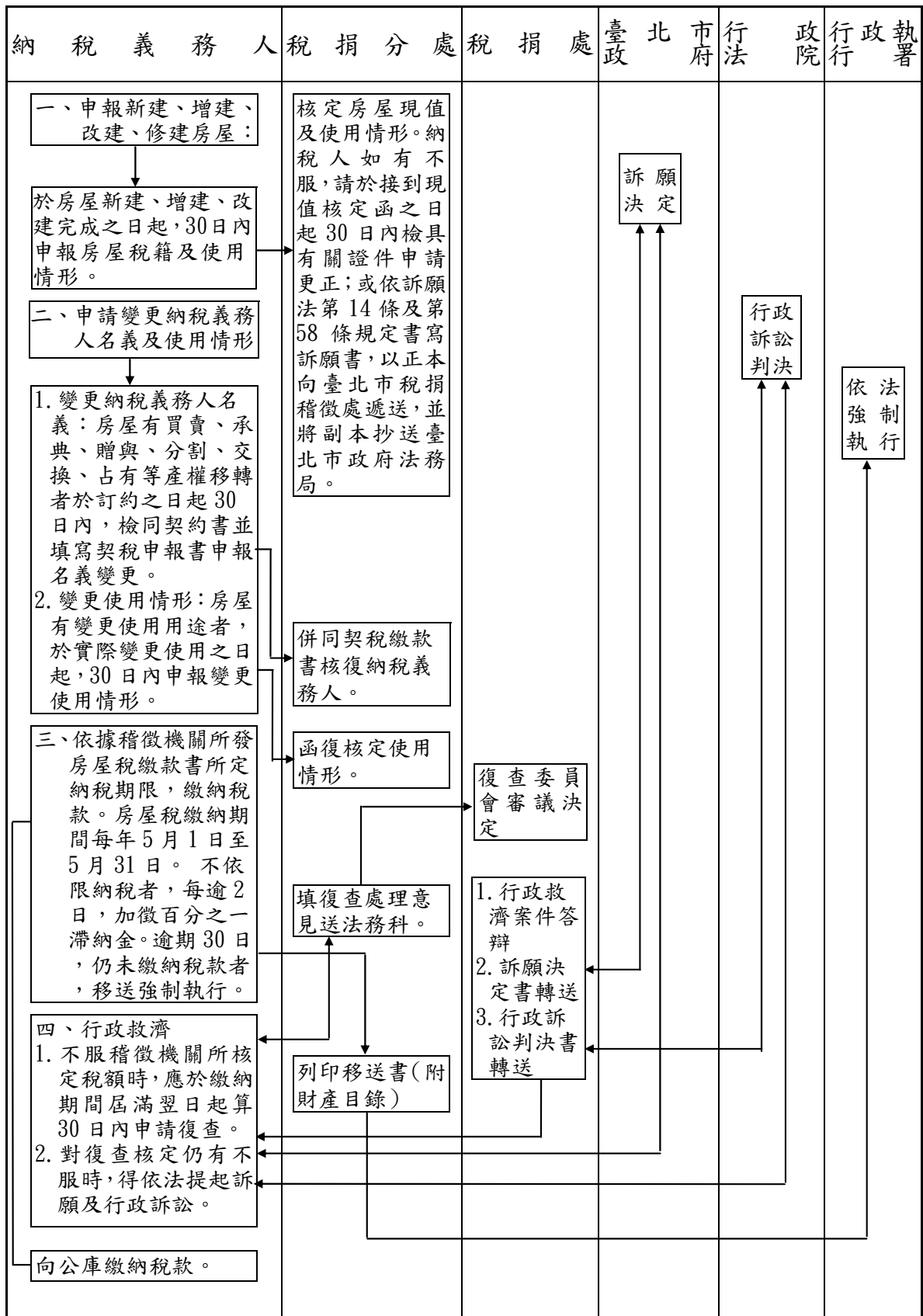

表 18 本處各項稅捐稽徵工作流程圖（續 4）

(五)契 稅



表 18 本處各項稅捐稽徵工作流程圖 (續 5)
(六)印 花 稅

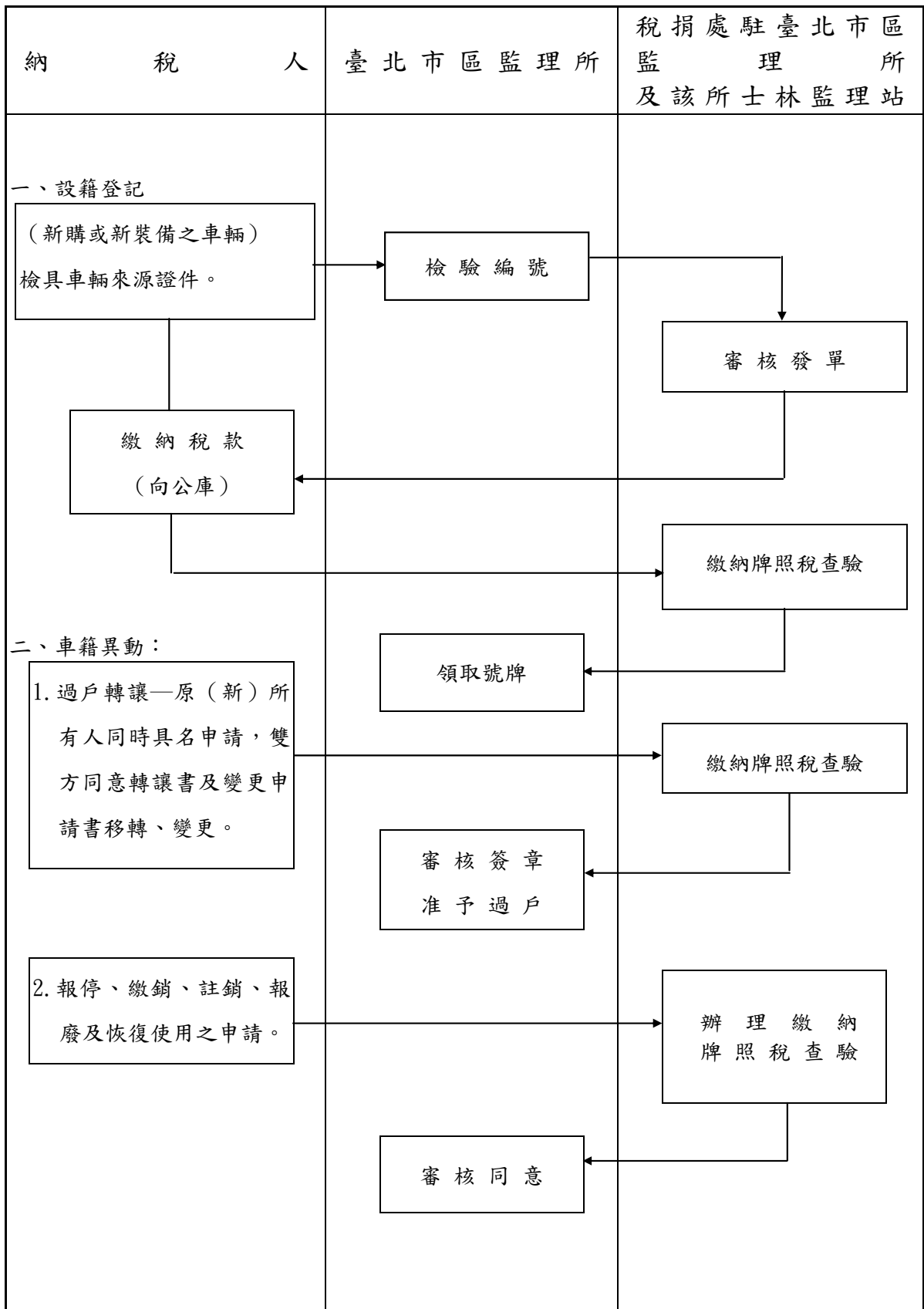

表 18 本處各項稅捐稽徵工作流程圖 (續 6)
(七) 娛樂稅

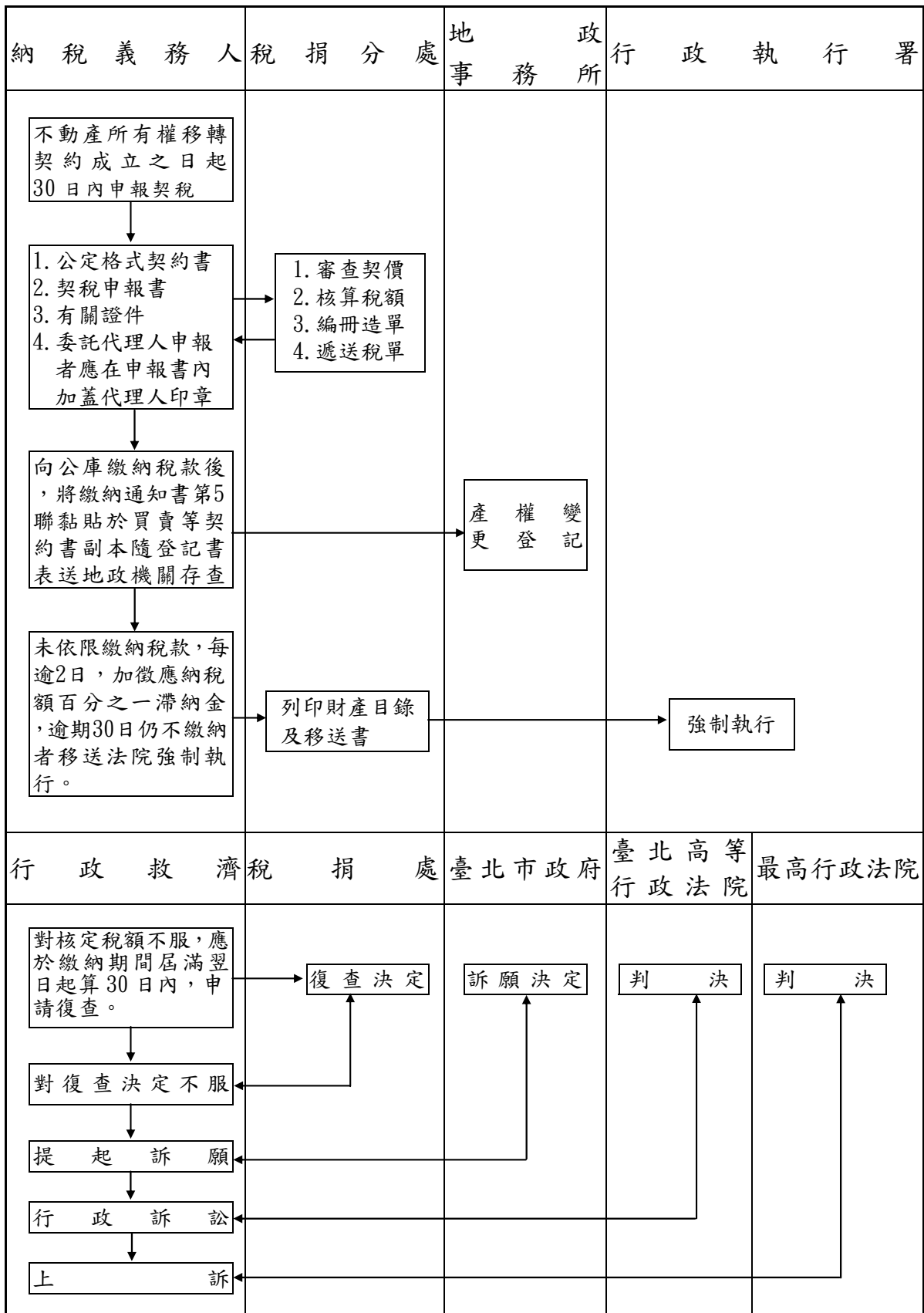

日期	分處	管理科	代徵人	稅捐分處	會計室	外僑組	市行政	府政	文	法	行	公
工	稅	稅	稅	稅	會	國	教	政	育	務	法	庫
部	捐	務	務	務	計	稅	行	府	文	科	務	庫
門	稅	稅	稅	稅	室	局	政	府	化	科	部	庫
	稅	務	務	務	室	局	府	府	局	科	署	庫
	捐	稅	稅	稅	室	組	政	政	局	科	署	庫
	稅	務	務	務	室	組	府	府	局	科	署	庫
	稅	稅	稅	稅	室	組	政	政	局	科	署	庫
	捐	稅	稅	稅	室	組	府	府	局	科	署	庫

表 18 本處各項稅捐稽徵工作流程圖 (續 7 完)
(八) 支票退稅

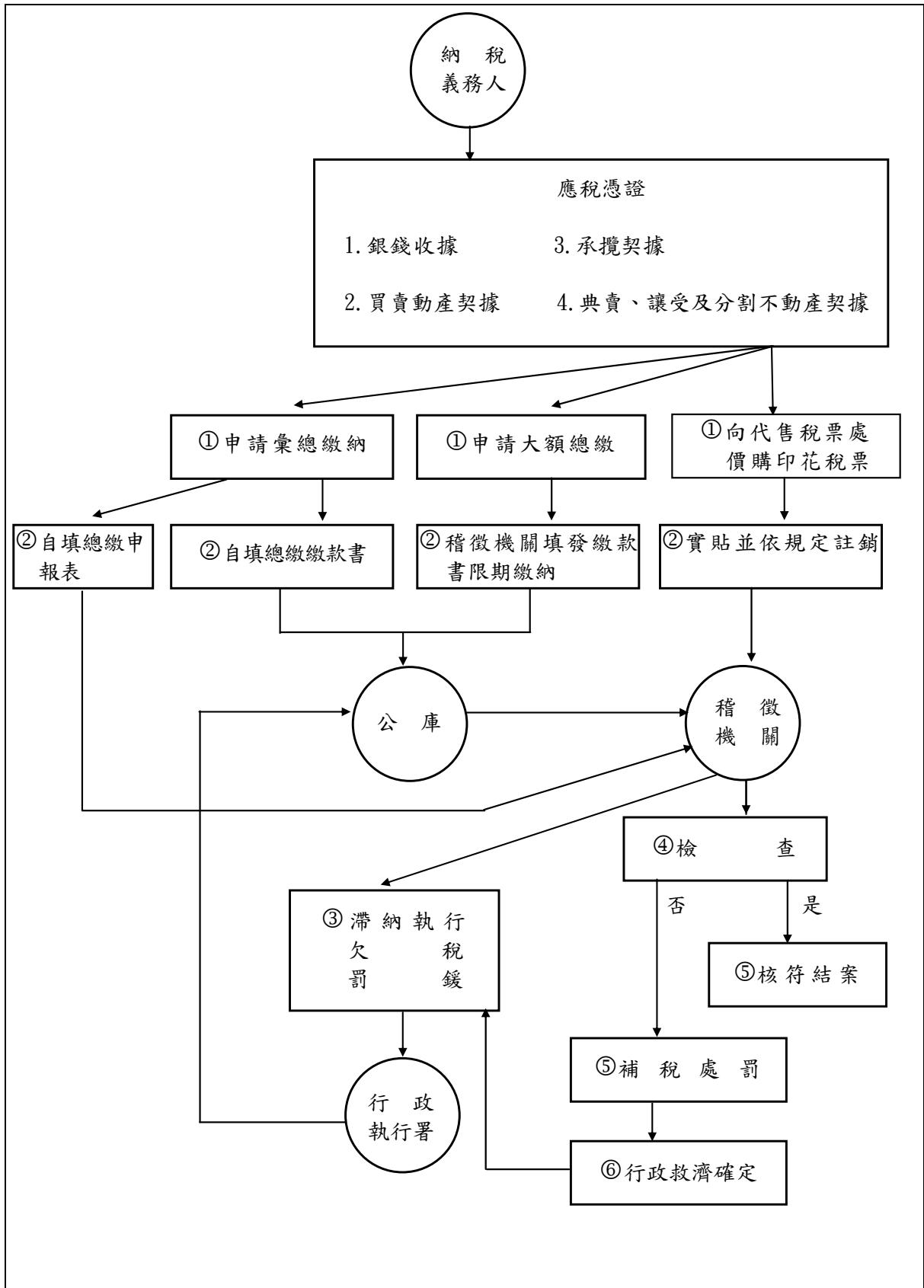
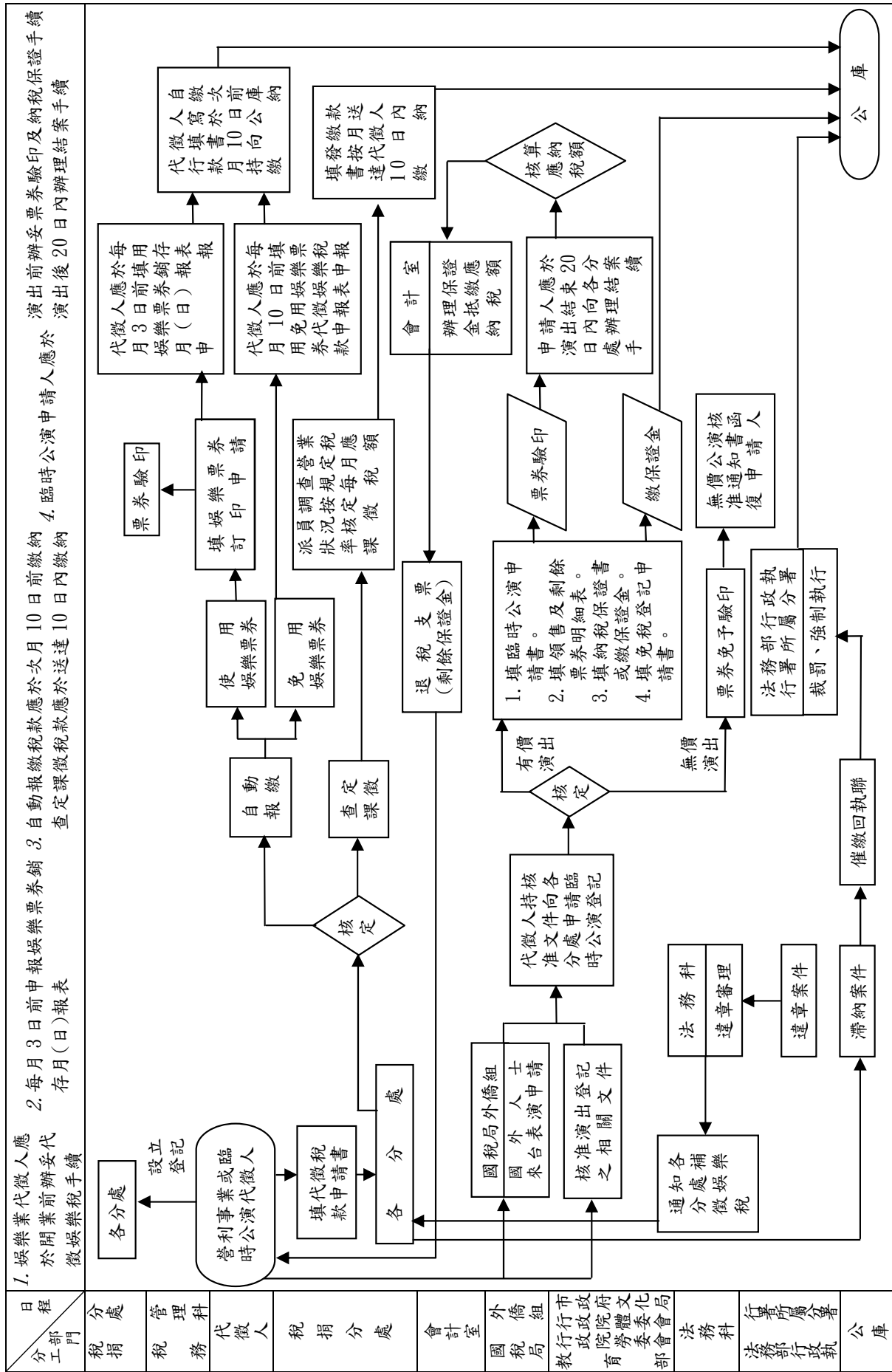
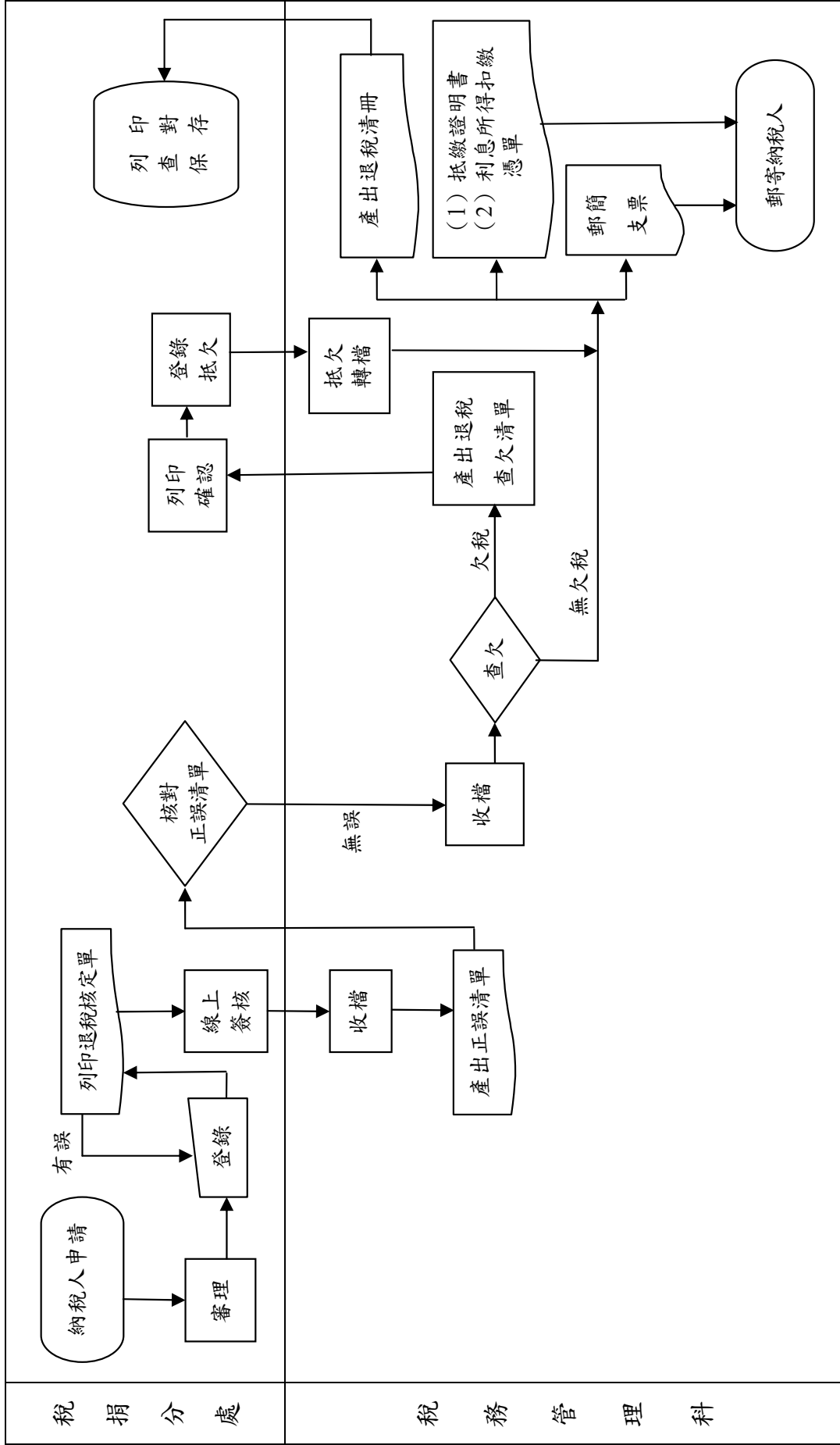

肆、行政組織

IV . Administrative Organization

一、沿革

民國 34 年全省實施統一稽徵制度，臺北市設第一、第二稅務稽徵所管轄本市稅捐稽徵業務，民國 36 年 1 月合併成立臺北市稅捐稽徵處，下設 6 課及城中、中山、延平、萬華、古亭、松山等分處，掌理國、省、地方稅捐稽徵事宜，在系統上隸屬於臺北市政府而受臺灣省政府財政廳指揮監督。

民國 56 年 7 月臺北市改制為直轄市，財政部同時成立臺北市國稅局（102 年更名為財政部臺北國稅局）負責國稅之徵收，本處負責直轄市稅捐稽徵，並同時增設建成分處。民國 57 年 7 月，將市郊景美、木柵、南港、內湖及陽明山管理局之士林、北投等 6 鄉鎮正式劃入為臺北市管轄，除士林、北投另成立為陽明山管理局稅捐稽徵處外，景美、木柵 2 區成立景美分處，南港、內湖 2 區成立南港分處，隸屬於本處。民國 60 年 7 月，因大安區發展迅速，為加強便民服務，由古亭分處撥出成立大安分處。民國 63 年 1 月，原陽明山管理局稅捐稽徵處改隸本處，改設為士林分處。民國 75 年 1 月建成分處併入延平分處，士林分處劃出成立北投分處。民國 77 年 6 月增設內湖及大同 2 個分處。

民國 80 年 7 月，配合臺北市行政區調整為 12 區，本處按行政區域及業務情況設置 13 個分處，分別為中正（城中、古亭合併）、中北、中南（中山分出）、北投、萬華、信義（松山分出）、大安、松山、南港、文山（景美更名）、士林、內湖、大同（延平併入）等分處，就近為市民提供最便捷的納稅服務。

民國 88 年營業稅改制為國稅，仍由本處代徵，10 月為落實組織精簡，提升組織效能，實施組織重整並彈性調整各分處內部架構，業務量較大之大安、中南、中北、松山 4 個分處改設 5 個股，業務量較小之北投、內湖、南港、文山 4 個分處改設 3 個股，其餘大同、中正、信義、萬華、士林等 5 分處仍設 4 個股，並將娛樂稅、印花稅稽徵業務改由分處辦理。

民國 92 年 1 月營業稅移撥由財政部臺北市國稅局稽徵。本處負責房屋稅、地價稅、土地增值稅、契稅、使用牌照稅、娛樂稅、印花稅等地方稅及工程受益費之稽徵。同時重新訂定組織架構，將總處調整為 5 科 5 室，分處仍維持不變，除大安分處設置 4 個股外，其餘分處設置 3 個股。為因應業務需要增設第 2 位副處長職位，於 94 年 1 月正式派任。

民國 95 年 1 月為擴增服務據點，使用牌照稅業務比照其他稅目，將稽徵作業之執行改由分處辦理，人員配合移撥分處。松山分處因牌照稅業務量及員額配置較多，專設 1 股辦理該項業務，改置為 4 個股，至民國 100 年 9 月為配合使用牌照稅稽徵業務回歸機會稅科管理，復調整為 3 個股。

臺北市稅捐稽徵處暨所屬各分處稽徵區域圖

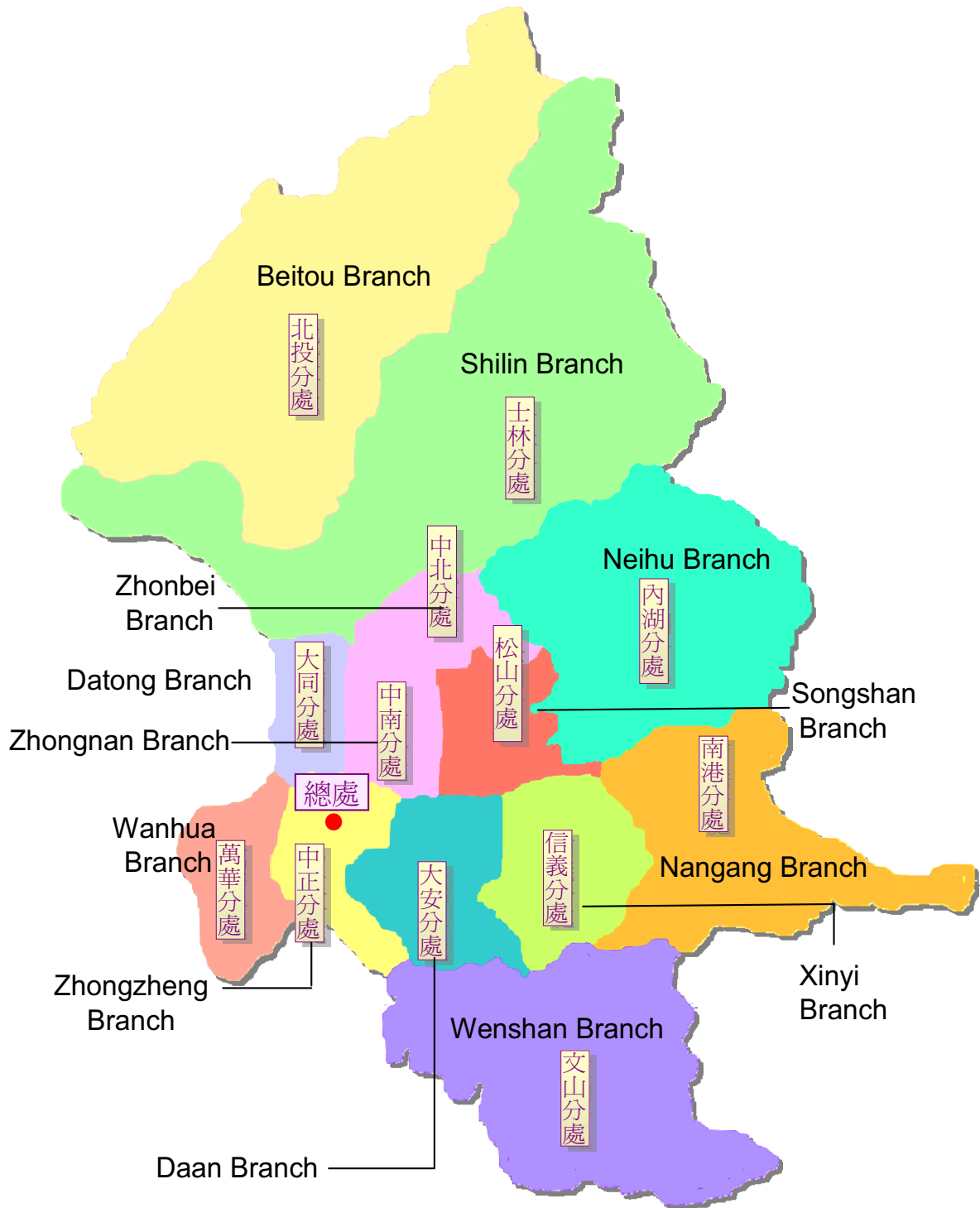

二、組織

本處組織：

依據臺北市政府 93 年 7 月 30 日府法三字第 09312725300 號令，「臺北市稅捐稽徵處組織規程」核定本處隸屬於臺北市政府財政局，置處長 1 人，綜理處務，並置副處長 2 人襄理處務，下設 5 科 5 室及 13 個分處掌理各項地方稅捐稽徵業務。

臺北市稅捐稽徵處組織圖

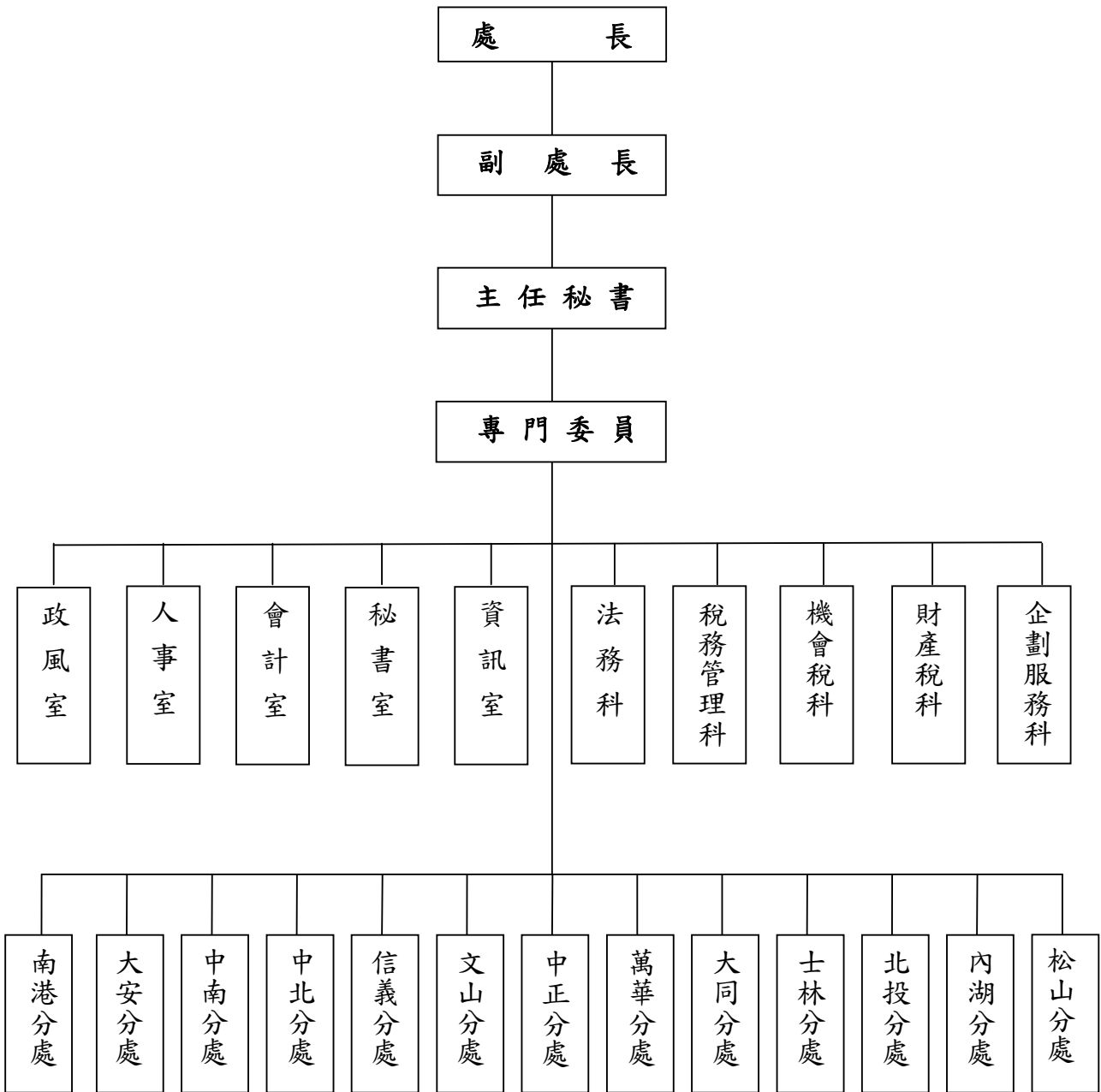

三、人事

本處奉准編制員額 846 人，民國 102 年 12 月底現有職員 743 人。現有人員按學歷別分析，研究所畢業者 68 人占 9.2%，大專畢業者 631 人占 84.9%，高中(職)畢業者 43 人占 5.8%，國中畢業者 1 人占 0.1%；按考試及格別來看，其中高等考試及格者 160 人占 21.5%，普通考試及格者 100 人占 13.5%，特種考試及格者 338 人占 45.5%，升等考試及格者 82 人占 11.0%，初等考試及格者 32 人占 4.3%，其他考試及格者 28 人占 3.8%，依其他法令進用者 3 人占 0.4%；按年齡別分，20 歲至 29 歲 102 人占 13.7%，30 歲至 39 歲 189 人占 25.4%，40 歲至 49 歲 228 人占 30.7%，50 歲至 59 歲 199 人占 26.8%，60 歲以上 25 人占 3.4%，平均年齡為 42.73 歲。



表 19 本處人事概況
 (一)法定員額與現有員額
 102年12月底

單位：人

職 稱	Position	法定員額 Budget Staff		現有員額 Actual Staff	備 註	
		職 等	員 額			
總 計	Total		846	743	本表法定員額係奉 臺北市政府 93 年 7 月 30 日府法三字第 09312725300 號令核 定之員額。	
處 長	Director	第 十 一 職 等	1	1		
副 處 長	Deputy Director	第 十 職 等	2	2		
主 任 秘 書	Chief Secretary	第 九 職 等	1	1		
專 門 委 員	Senior Specialist	第 九 職 等	2	1		
科 長	Section Chief	第 八 職 等	5	5		
分 處 主 任	Manager, Branch	第 八 至 九 職 等	13	13		
主 任	Chief	第 八 職 等	2	2		
秘 書	Secretary	第 七 至 八 職 等	3	3		
督 導	Inspector	第 七 至 八 職 等	3	2		
審 核 員	Revenue Assessor	第 七 至 八 職 等	19	18		
專 員	Specialist	第 七 至 八 職 等	1	1		
股 長	Sub-section Chief	第 七 職 等	62	61		
分 析 師	Systems Analyst	第 七 職 等	2	1		
設 計 師	Systems Designer	第 五 或 六 至 七 職 等	14	13		
管 理 師	Systems Coordinator	第 五 或 六 至 七 職 等	4	4		
助 理 設 計 師	Assistant Systems Designer	第 三 至 五 職 等	6	5		
助 理 管 理 師	Assistant Systems Coordinator	第 三 至 五 職 等	1	1		
稅 務 員	Revenue Officer	第 五 或 六 至 七 職 等	344	315		
助 理 稅 務 員	Revenue Assistant	第 三 至 五 職 等	167	157		
科 員	Section Assistant	第 五 或 六 至 七 職 等	6	6		
辦 事 員	Senior Clerk	第 三 至 五 職 等	19	18		
書 記	Clerk	第 一 至 三 職 等	124	73		(內 3 人俟雇員出 缺後改置)

續下頁

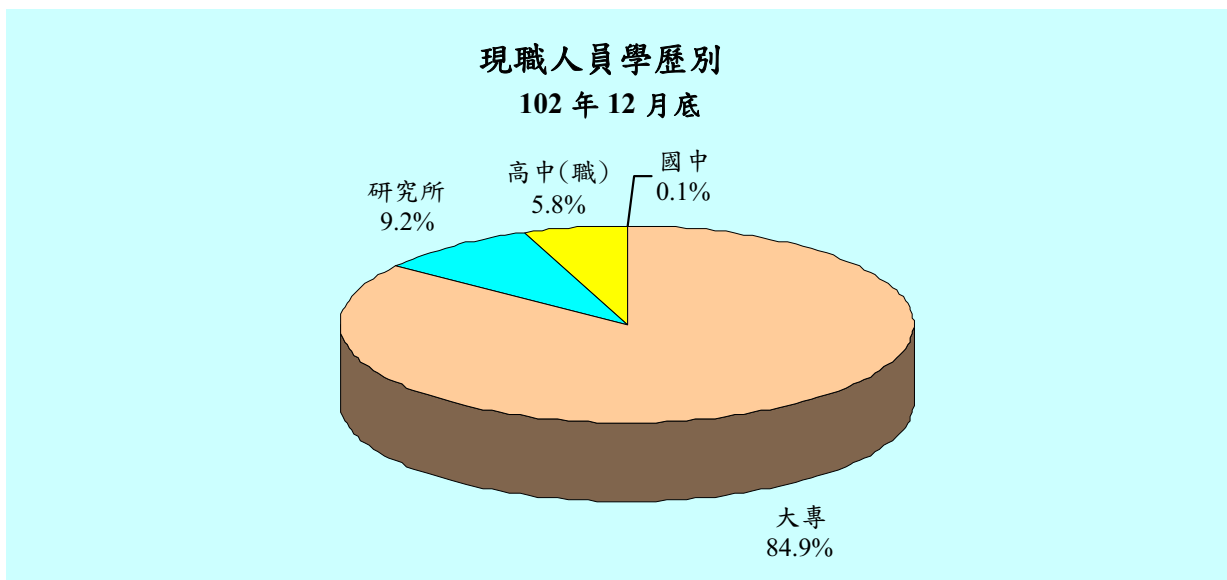
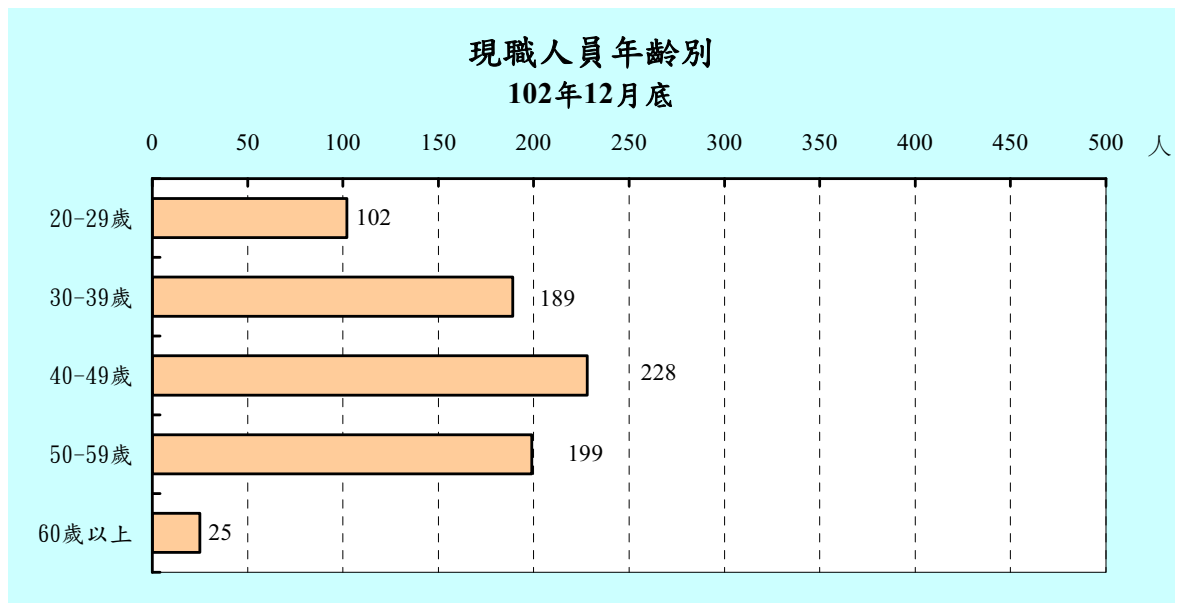
表 19 本處人事概況(續 1)

(一)法定員額與現有員額

102年12月底

單位：人

職 稱 Position	法定員額 Budget Staff		現有員額 Actual Staff	備 註
	職 等	員 額		
會計室 Accounting office	會計主任 Chief Accounting Officer	第 八 職 等	1	
	專員 Specialist	第 七 至 八 職 等	1	1
	股長 Sub- section Chief	第 七 職 等	4	4
	科員 Section Assistant	第 五 或 六 至 七 職 等	11	11
	辦事員 Senior Clerk	第 三 至 五 職 等	1	1
	書記 Clerk	第 一 至 三 職 等	2	1
	人 事 室 Personnel Office	主任 Chief Personnel Officer	第 八 職 等	1
專員 Specialist		第 七 至 八 職 等	1	1
股長 Sub- section Chief		第 七 職 等	3	3
科員 Section Assistant		第 五 或 六 至 七 職 等	8	7
助理員 Assistant		第 四 至 五 職 等	2	1 (內 1 人得列 薦任)
書記 Clerk		第 一 至 三 職 等	1	1
政 風 室 Government Ethics Office		主任 Chief Government Ethics Officer	第 八 職 等	1
	股長 Sub- section Chief	第 七 職 等	2	1
	科員 Section Assistant	第 五 或 六 至 七 職 等	4	4
	辦事員 Senior Clerk	第 三 至 五 職 等	1	1
	書記 Clerk	第 一 至 三 職 等	1	1

附註：根據本處人事室資料編製。

表 19 本處人事概況(續 2)

(二) 年齡與職等、性別

102 年 12 月底

單位：人

年 齡 age	官 等 Official Classes					性 別 Sex		
	共 計 Total	10-14 職等 Selected Appointment	6-9 職等 Recommended Appointment	1-5 職等 Delegated Appointment	雇 員 Assistant Clerk	共 計 Total	男 Male	女 Female
總 計 Grand Total	743	3	370	367	3	743	151	592
20 歲 - 29 歲	102	—	35	67	—	102	16	86
30 歲 - 39 歲	189	—	87	102	—	189	50	139
40 歲 - 49 歲	228	—	132	96	—	228	30	198
50 歲 - 59 歲	199	1	108	87	3	199	49	150
60 歲 以 上	25	2	8	15	—	25	6	19

(三) 學歷及考試

102 年 12 月底

單位：人

學 歷 及 考 試 別 Educational & Examination	共 計 Total	10-14 職等 Selected Appointment	6-9 職等 Recommended Appointment	1-5 職等 Delegated Appointment	雇 員 Assistant Clerk
(1) 學 歷 Education	743	3	370	367	3
研 究 所 Graduate School	68	—	51	17	—
大 專 Junior College	631	3	315	311	2
高 中 (職) Senior High School	43	—	4	38	1
國 (初) 中 及 以 下 Junior High School and Under	1	—	—	1	—
(2) 考 試 Examination	743	3	370	367	3
高 等 考 試 Senior Civil Service Exam.	160	1	145	14	—
普 通 考 試 Junior Civil Service Exam.	100	—	38	62	—
特 種 考 試 Special Civil Service Exam.	338	1	136	201	—
升 等 考 試 Rank Promotion Service Exam.	82	1	40	41	—
初 等 考 試 Elementary Civil Service Exam.	32	—	—	32	—
其 他 考 試 Other Civil Service Exam.	28	—	11	14	3
依 其 他 法 令 進 用 By Other Means	3	—	—	3	—

表 19 本處人事概況(續 3 完)

(四)年 資

102 年 12 月底

單位：人

年 資 Seniority	共 計 Total	10—14 職等 Selected Appointment	6—9 職等 Recommended Appointment	1—5 職等 Delegated Appointment	雇 員 Assistant Clerk
總 計 Grand Total	743	3	370	367	3
5 年 以 下	308	—	130	178	—
6 年— 9 年	76	—	24	52	—
10 年—14 年	81	—	41	40	—
15 年—19 年	142	—	76	64	2
20 年—24 年	68	—	44	24	—
25 年—29 年	36	—	29	7	—
30 年 以 上	32	3	26	2	1

(五)工 作 類 別

102 年 12 月底

單位：人

工 作 類 別 Job	共 計 Total	10—14 職等 Selected Appointment	6—9 職等 Recommended Appointment	1—5 職等 Delegated Appointment	雇 員 Assistant Clerk
總 計 Grand Total	743	3	370	367	3
行 政	63	—	9	54	—
財 政	607	3	319	285	—
人 事	14	—	8	6	—
會 計	18	—	13	5	—
雇 員	3	—	—	—	3
資 訊 處 理	30	—	16	14	—
政 風	8	—	5	3	—
安 全 保 防	—	—	—	—	—

表 20 本處歲出預決算數

單位：新臺幣元

年度及科目別	預 算		決 算		決算數 占預算數 之比率 % (2/1)×100
	金 額 (1)	%	金 額 (2)	%	
93 年 度	1,001,426,569	100.0	948,839,912	100.0	94.7
94 年 度	922,830,712	100.0	908,367,765	100.0	98.4
95 年 度	929,515,635	100.0	918,257,368	100.0	98.8
96 年 度	917,289,764	100.0	895,615,954	100.0	97.6
97 年 度	923,887,755	100.0	895,044,198	100.0	96.9
98 年 度	925,665,198	100.0	898,324,537	100.0	97.0
99 年 度	910,138,102	100.0	898,108,142	100.0	98.7
100 年 度	924,158,185	100.0	915,283,662	100.0	99.0
101 年 度	926,239,026	100.0	898,931,066	100.0	97.1
102 年 度	937,691,092	100.0	916,073,419	100.0	97.7
一般行政	170,062,648	18.1	167,218,683	18.3	98.3
行政管理	170,062,648	18.1	167,218,683	18.3	98.3
稅捐稽徵業務	748,271,360	79.8	732,211,635	79.9	97.9
財產稅稽徵	362,272,414	38.6	358,632,636	39.1	99.0
機會稅稽徵	67,149,824	7.2	63,907,931	7.0	95.2
稅務管理	217,506,849	23.2	213,236,121	23.3	98.0
違章及行政救濟	16,135,376	1.7	16,038,840	1.8	99.4
電子處理資料	85,206,897	9.1	80,396,107	8.8	94.4
建築及設備	17,016,184	1.8	14,618,347	1.6	85.9
土地購置	1,000,000	0.1	—	--	--
營建工程	11,132,581	1.2	9,917,304	1.1	89.1
交通及運輸設備	2,160,000	0.2	2,120,000	0.2	98.1
其他設備	2,723,603	0.3	2,581,043	0.3	94.8
接受補助建設支出	2,340,900	0.2	2,024,754	0.2	86.5
接受中央政府補助建設支出	2,340,900	0.2	2,024,754	0.2	86.5

資料來源：依據審計部臺北市審計處審核決算審定書編製。

附註：1. 本表未包括統籌科目。

2. 102年度決算數尚未經審計部臺北市審計處審定。

中華民國 102 年度
臺北市稅捐統計年報

出版機關：臺北市稅捐稽徵處

發行人：黃素津

編輯：臺北市稅捐稽徵處會計室

地址：臺北市中正區北平東路 7 之 2 號

電話：(02)23949211 分機 341

網址：www.tpctax.taipei.gov.tw

創刊日期：中華民國 42 年 2 月

出版日期：中華民國 103 年 3 月

出刊頻率：年刊

本刊登載於本處網站



依法納稅是義務
合法節稅是權利
主動退稅是責任