

中華民國106年度
臺北市稅捐統計年報

YEARBOOK OF MUNICIPAL TAX
STATISTICS OF TAIPEI CITY
2017



臺北市稅捐稽徵處
TAIPEI CITY **R**EVENUE **S**ERVICE
107年3月編製

編 製 說 明

- 一、本刊之編製，旨在提供本處稽徵業務執行與成果資料，以為公務計畫、執行、考核及財務管理上之參考。
- 二、本刊資料內容包括稅收概況、稅收統計、稅源及其他、行政組織等 4 大項。
- 三、本刊所稱「年度」係指政府會計年度，採曆年制(當年 1 月 1 日至同年 12 月 31 日)。
- 四、本刊數字因尾數四捨五入，故部分總數與細項之間，或有未能吻合情事，計算時仍以原始數據計算。
- 五、本刊所有符號「—」表示無數值，「--」表示無意義數值，「...」表示數值不明或尚未產生資料，「0」表示有數值而不及半單位，數字前加(-)者表示退稅或減免數，(+)者表示增加數，「Ⓘ」表示修正數。
- 六、本刊以前各期數字，若與本期有出入者，以本期所列數字為準。

目 次

壹、稅收概況

一、106 年度稅收概況	2
二、近 10 年稅收	3
三、地價稅	4
四、土地增值稅	5
五、房屋稅	6
六、使用牌照稅	7
七、契稅	8
八、印花稅	9
九、娛樂稅	10

貳、稅收統計

表 1 各項稅捐徵績比較	12
表 2 歷年各項稅捐預算數、查定數與實徵數	
(一)總計	14
(二)稅課收入	
1. 合計	16
2. 地價稅	18
3. 土地增值稅	20
4. 房屋稅	22
5. 使用牌照稅	24
6. 契稅	26
7. 印花稅	28
8. 娛樂稅	30

CONTENTS

I. Analysis of Revenues from Taxes

A. Tax Revenues in 2017	2
B. Tax Revenues in Nearly 10 Years	3
C. Land Value Tax	4
D. Land Value Increment Tax	5
E. House Tax	6
F. Vehicle License Tax	7
G. Deed Tax	8
H. Stamp Tax	9
I. Amusement Tax	10

II. Tax Revenue Statistics

Table 1. Net Tax Revenues Compare	12
Table 2. Budget Amount, Audited Amount and Actual Collection in Recent Years	
(I) Grand Total	14
(II) Revenues from Taxes	
1. Total	16
2. Land Value Tax	18
3. Land Value Increment Tax	20
4. House Tax	22
5. Vehicle License Tax	24
6. Deed Tax	26
7. Stamp Tax	28
8. Amusement Tax	30

9. 九年國民義務教育附徵教育捐

(1)小計	32
(2)房屋稅	34
(3)娛樂稅	36
(三)工程受益費	38
(四)罰鍰收入	40
(五)規費收入	42
表 3 各項稅捐納庫數	
(一)歷年別	44
(二)稅目別	46
表 4 歷年各項稅捐實徵淨額及指數	48
表 5 本處各項稅捐稽徵成本	52

參、稅源及其他

表 6 地價稅稅源	54
表 7 土地增值稅稅源	56
表 8 房屋稅稅源	58
表 9 使用牌照稅稅源	62
表 10 契稅稅源	64
表 11 印花稅稅源	66
表 12 娛樂稅稅源	68
表 13 違章漏稅案件處理及財務罰鍰執行情形	70
表 14 各項稅捐滯納案件移送執行情形	74
表 15 查(核)定開徵數及未徵數情形	76

9. Education Surtax	
(1) Subtotal	32
(2) House Tax	34
(3) Amusement Tax	36
(III) Construction Benefit Fee	38
(IV) Punitive Fine Revenue	40
(V) Fees Revenue	42
Table 3. Taxation Forwarded to Treasury	
(I) Fiscal Year	44
(II) Item of Tax	46
Table 4. Net Amount Remitted and Index in Recent Years	48
Table 5. Cost of Tax Levying	52

III. Tax Sources and Others

Table 6. Sources of Land Value Tax	54
Table 7. Sources of Land Value Increment Tax	56
Table 8. Sources of House Tax	58
Table 9. Sources of Vehicle License Tax	62
Table 10. Sources of Deed Tax	64
Table 11. Sources of Stamp Tax	66
Table 12. Sources of Amusement Tax	68
Table 13. The Management of Cases of Tax Evasion Against Law and Execution Status of Fine	70
Table 14. The Status of Delayed Case Transferred to Execution	74
Table 15. The Management of Opening Collection for Assessed(Verified) and of Tax Not Collected	76

表 16 各項稅捐現行稅率表	84
表 17 各項稅捐劃解分配率	92
表 18 本處各項稅捐稽徵工作流程圖	
(一)地價稅	93
(二)土地增值稅	94
(三)房屋稅	95
(四)使用牌照稅	96
(五)契稅	97
(六)印花稅	98
(七)娛樂稅	99
(八)支票退稅	100

肆、行政組織

一、沿革 (附圖)	102
二、組織 (附圖)	105
三、人事 (附圖)	107
表 19 本處人事概況	
(一)法定員額與現有員額	108
(二)年齡與職等、性別	110
(三)學歷及考試	110
(四)年資	111
(五)工作類別	111
表 20 本處歲出預決算數	112

Table 16. Current Tax Rates for Taxation	84
Table 17. The Distribution Rates of Tax	92
Table 18. Work Flow Chart	
(I) Land Value Tax	93
(II) Land Value Increment Tax	94
(III) House Tax	95
(IV) Vehicle License Tax	96
(V) Deed Tax	97
(VI) Stamp Tax	98
(VII) Amusement Tax	99
(VIII) Check Refund	100

IV. Administrative Organization

A. The History	102
B. Organization	105
C. Personnel	107
Table 19. Personnel Statistic	
(I) Personnel Management & Present Personnel	108
(II) By Age & Official Class & Sex	110
(III) By Educational Attainment & Recruitment Way	110
(IV) By Length of Service	111
(V) Work Type	111
Table 20. Budget and Closed Account of Expenditures	112

壹、稅收概況

I . Analysis of Revenues from Taxes

一、106 年度稅收概況

106 年度本市地方稅稅收實徵淨額 748.89 億元，較預算數 750.14 億元，短徵 1.25 億元，年度預算達成率 99.8%，各項稅收與預算數比較，除土地增值稅因受土地公告現值調降、大額移轉稅款減少因素影響，短徵 29.84 億元，及契稅短徵 2.9 億元外，其餘各稅均為超徵，其中房屋稅因賡續實施高級住宅加價課徵房屋稅政策，以及加強房屋稅稅籍與使用情形清查，實徵淨額達 156.26 億元，超徵 17.26 億元為最多；其次為地價稅超徵 10.12 億元；此外，使用牌照稅、印花稅及娛樂稅超徵金額分別為 2.06 億元、1.79 億元及 0.26 億元。

106 年度地方稅稅課收入

單位：新臺幣億元

項目 稅目	預算數 (1)	實徵淨額 (2)	超(短)徵		預算達成率 (5)=(2)/(1)*100
			金額 (3)=(2)-(1)	百分比 (4)=(3)/(1)	
稅課收入	750.14	748.89	-1.25	-0.2%	99.8%
地價稅	287.84	297.96	10.12	3.5%	103.5%
土地增值稅	186.00	156.16	-29.84	-16.0%	84.0%
房屋稅	139.00	156.26	17.26	12.4%	112.4%
使用牌照稅	73.00	75.06	2.06	2.8%	102.8%
契稅	18.00	15.10	-2.90	-16.1%	83.9%
印花稅	44.00	45.79	1.79	4.1%	104.1%
娛樂稅	2.30	2.56	0.26	11.4%	111.4%
教育捐	—	—	--	--	--

106 年度稅收實徵淨額各稅比重

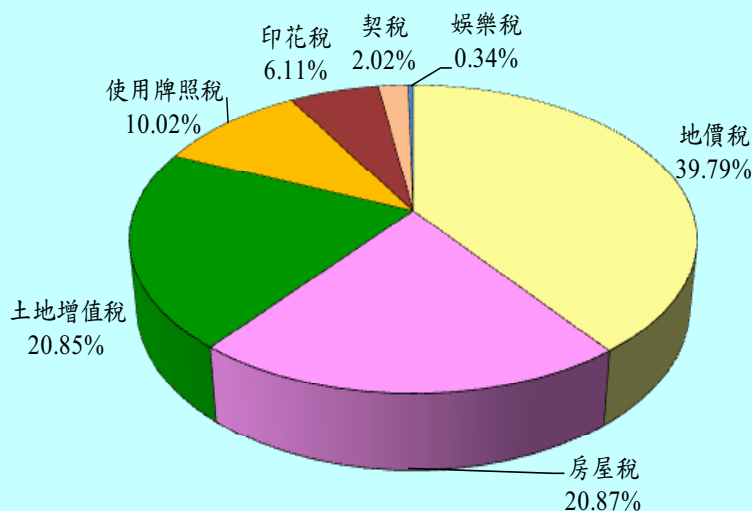

二、近 10 年稅收

近 10 年稅課收入

單位：新臺幣億元

年度別	預算數	實徵淨額	超(短)徵		實徵淨額與上年度增減比較	
			金額	百分比	金額	百分比
97	540.34	565.71	25.37	4.7%	--	--
98	535.20	573.45	38.25	7.1%	7.74	1.4%
99	527.10	608.45	81.35	15.4%	35.00	6.1%
100	562.68	619.99	57.31	10.2%	11.54	1.9%
101	610.50	621.89	11.39	1.9%	1.90	0.3%
102	604.30	663.11	58.81	9.7%	41.22	6.6%
103	630.75	672.91	42.16	6.7%	9.80	1.5%
104	650.75	768.23	117.48	18.1%	95.32	14.2%
105	715.47	753.22	37.75	5.3%	-15.01	-2.0%
106	750.14	748.89	-1.25	-0.2%	-4.33	-0.6%

近 10 年稅課收入預算數與實徵淨額

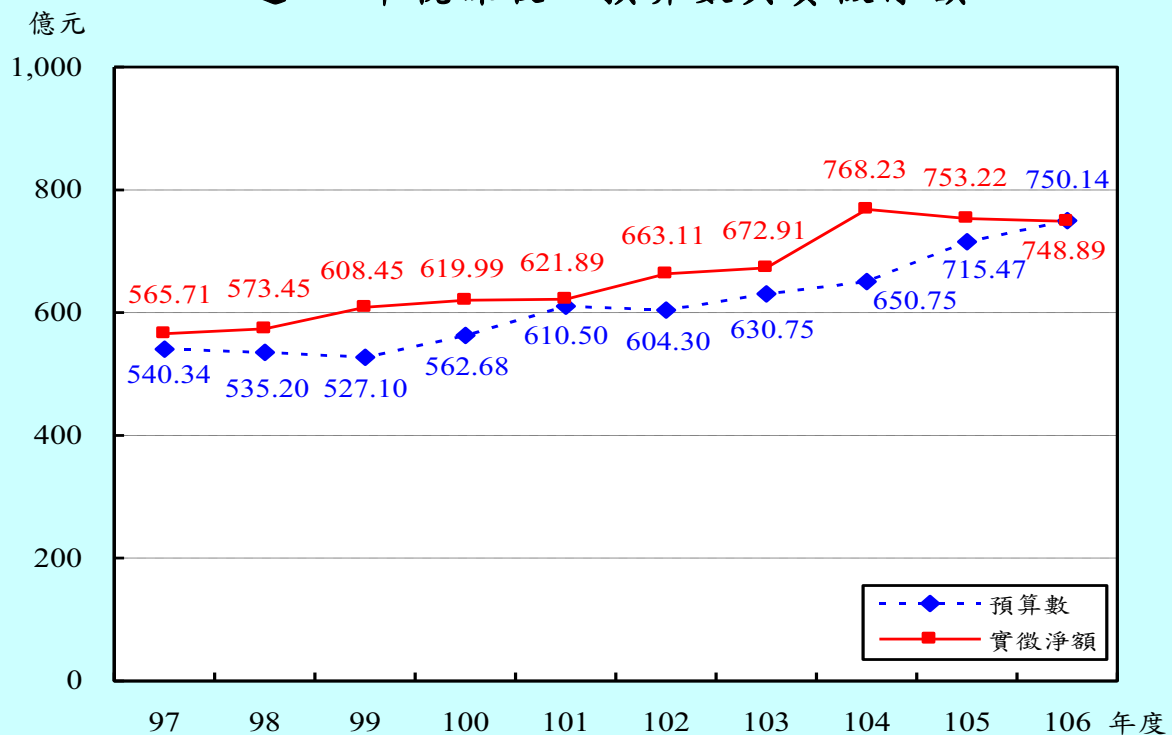

三、地價稅

106 年度實徵淨額 297.96 億元，與預算數 287.84 億元比較，增加 10.12 億元，超徵 3.5%；較上年度實徵淨額 294.96 億元增加 3 億元，成長 1%。

106 年度因執行稅籍清查及清理欠稅績效顯著，且開徵徵起率較以前年度為高，致稅收超徵且較上年度增加。

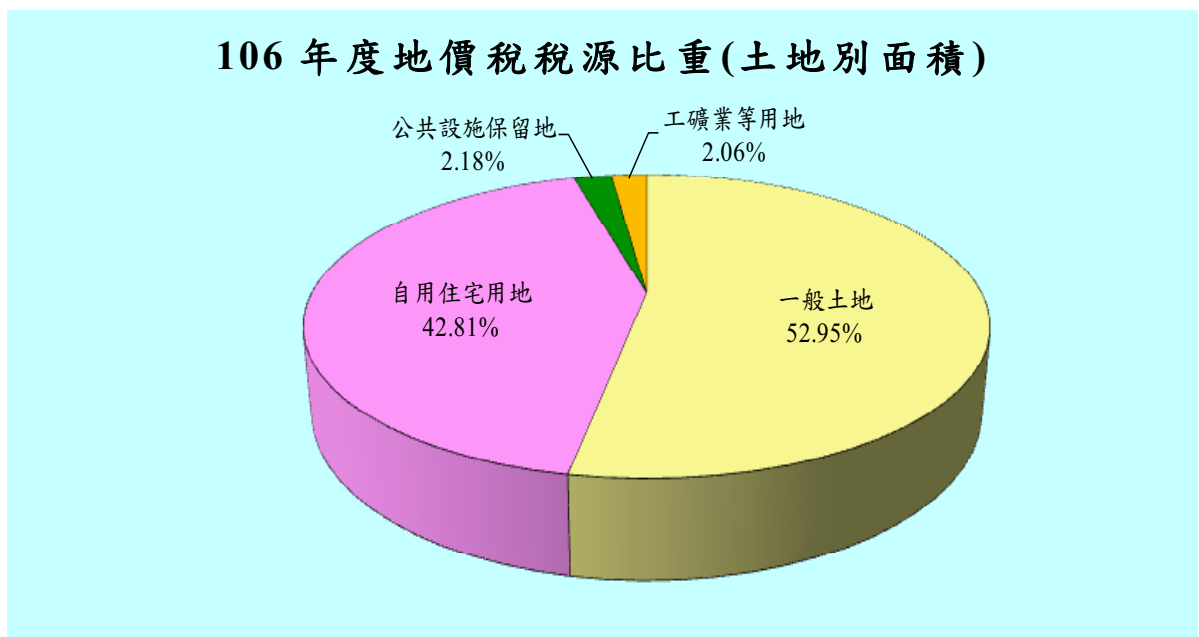
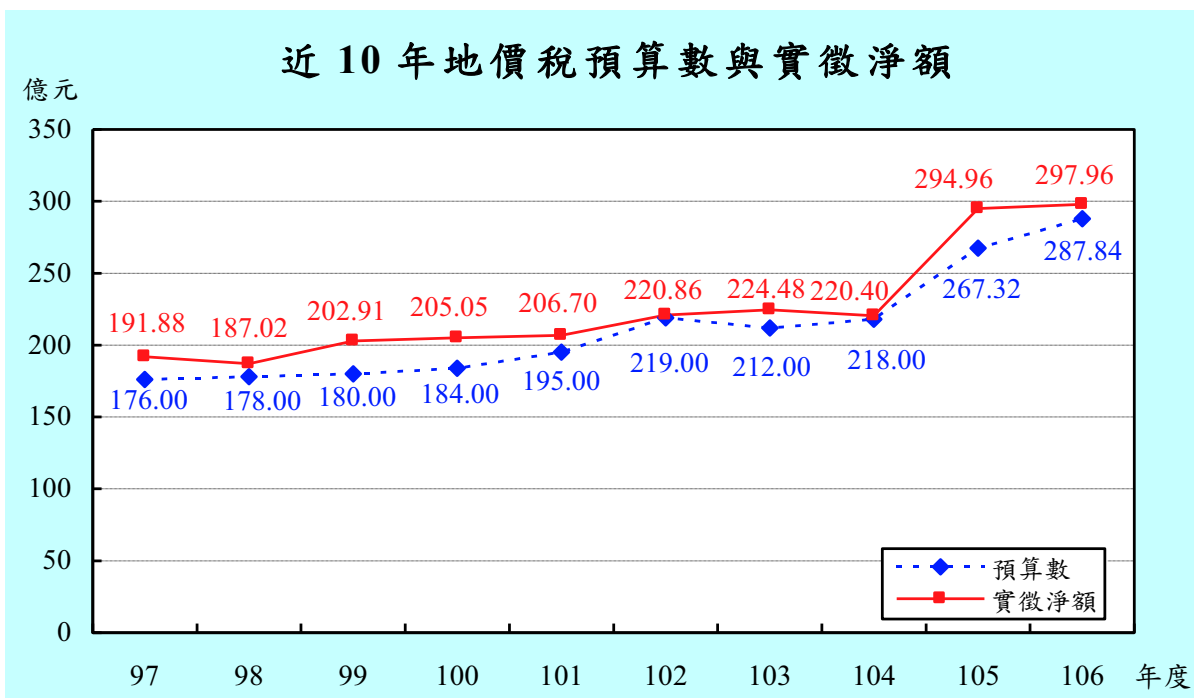

四、土地增值稅

106 年度實徵淨額 156.16 億元，與預算數 186 億元比較，減少 29.84 億元，短徵 16%；較上年度實徵淨額 167.69 億元減少 11.53 億元，負成長 6.9%。

106 年度因受本市土地公告現值平均調降 2.43% 及大額移轉稅款較上年度大幅減少影響，致稅收短徵且較上年度減少。

近 10 年土地增值稅預算數與實徵淨額

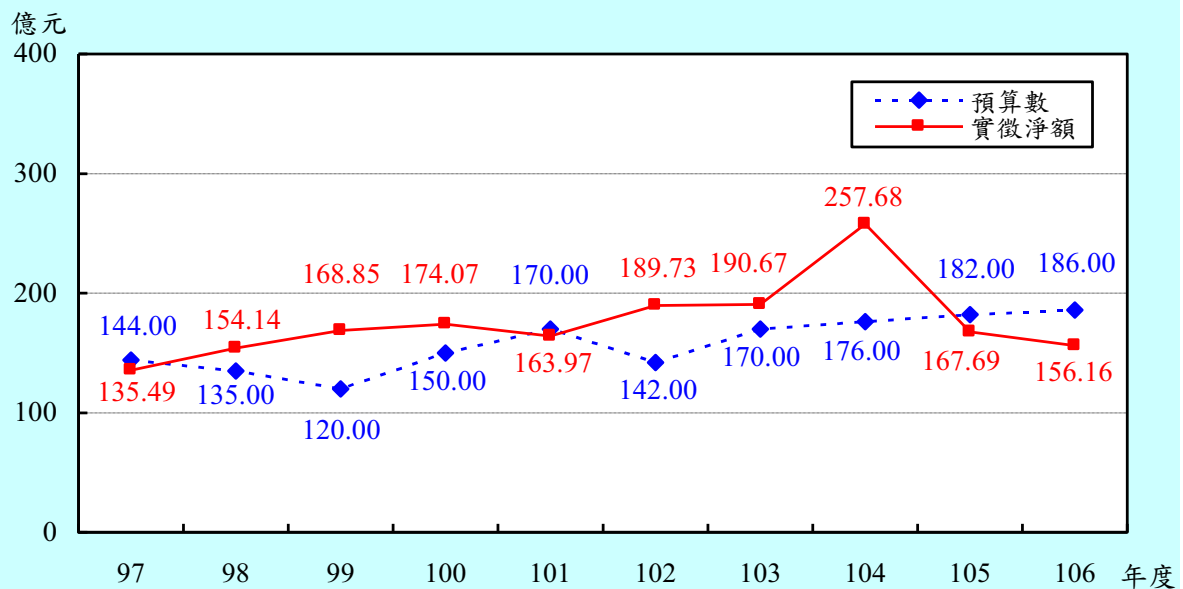

近 10 年移轉土地增值情形

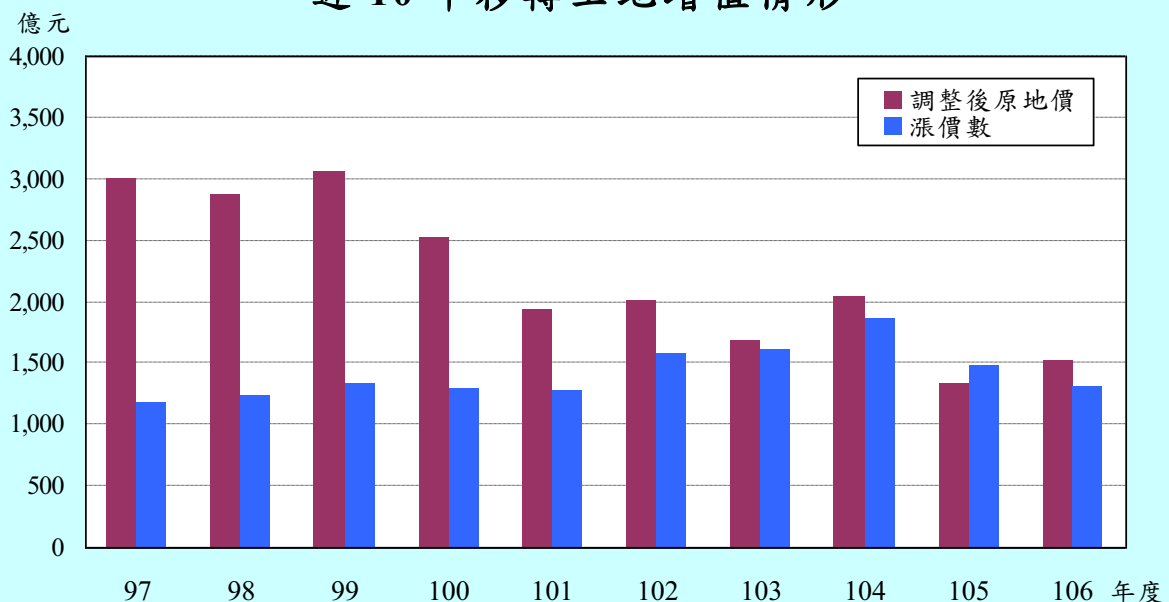

五、房屋稅

106 年度實徵淨額 156.26 億元，與預算數 139 億元比較，增加 17.26 億元，超徵 12.4%；較上年度實徵淨額 152.73 億元增加 3.53 億元，成長 2.3%。

106 年度因賡續實施高級住宅加價課徵房屋稅政策，並自 103 年 7 月 1 日起，調高新建房屋構造標準單價、調整部分路段率、提高非自住之其他供住家用與供私人醫院、診所及自由職業事務所使用之房屋稅率，以及加強房屋稅稅籍與使用情形清查、積極清理欠稅，致稅收超徵且較上年度增加。

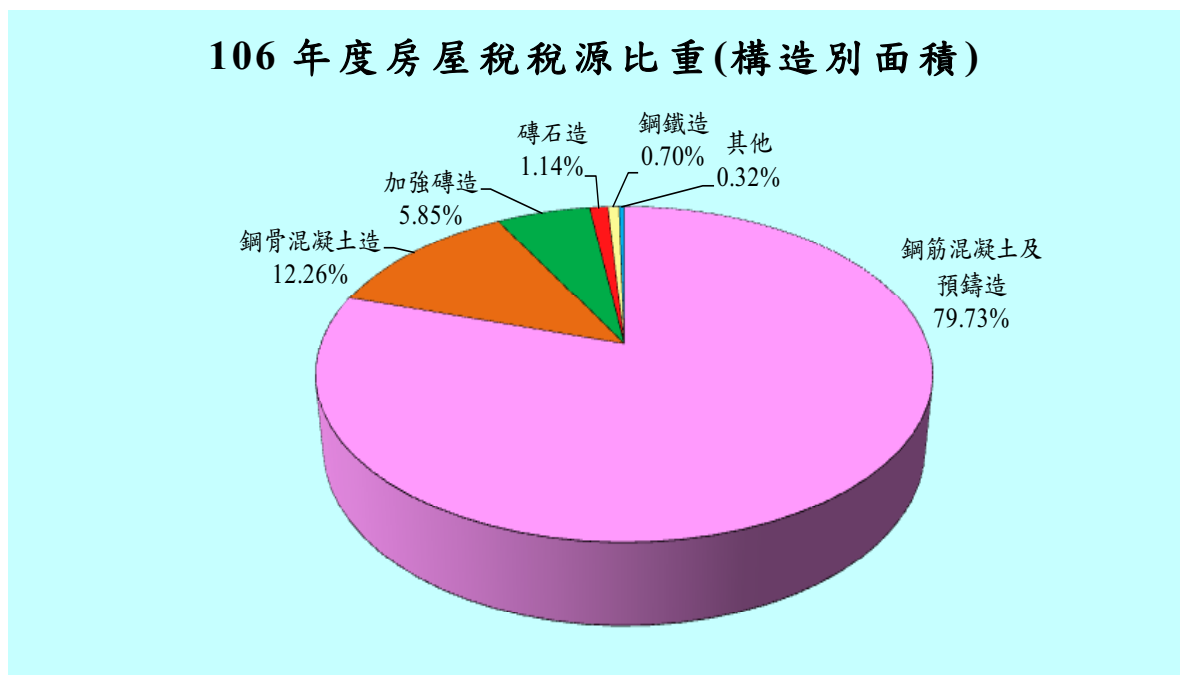
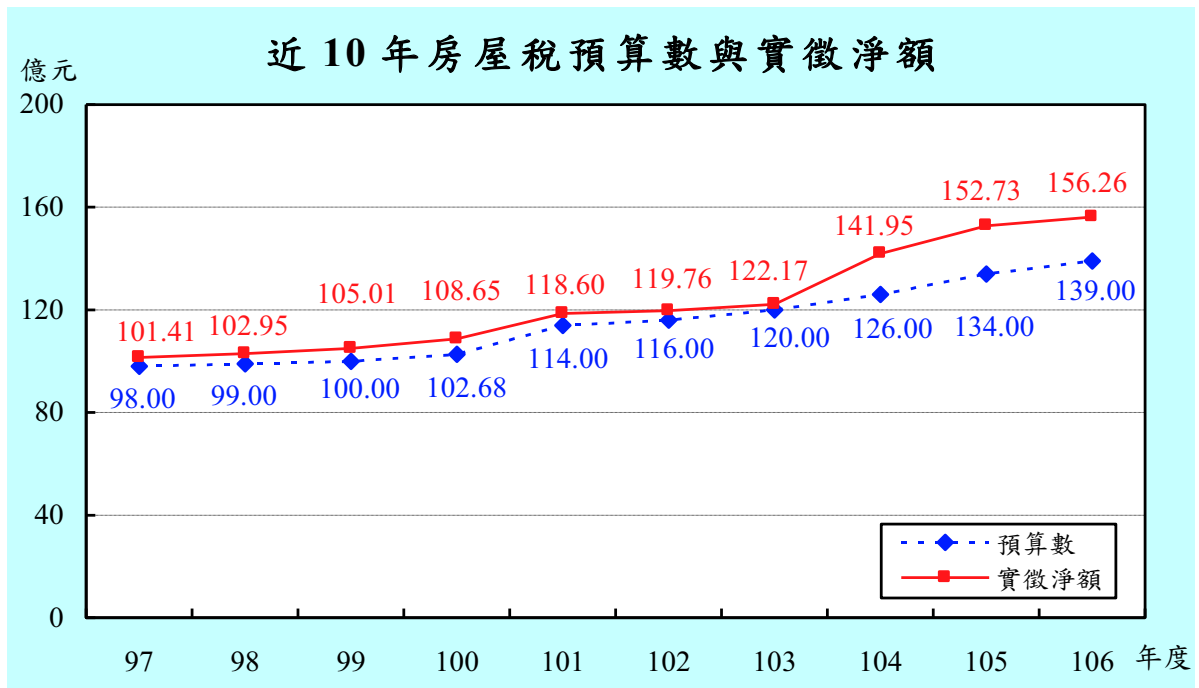

六、使用牌照稅

106 年度實徵淨額 75.06 億元，與預算數 73 億元比較，增加 2.06 億元，超徵 2.8%；較上年度實徵淨額 74.8 億元增加 0.26 億元，成長 0.3%。

106 年度因車輛數增加、積極辦理免稅案件清查及欠稅清理，致稅收超徵且較上年度增加。

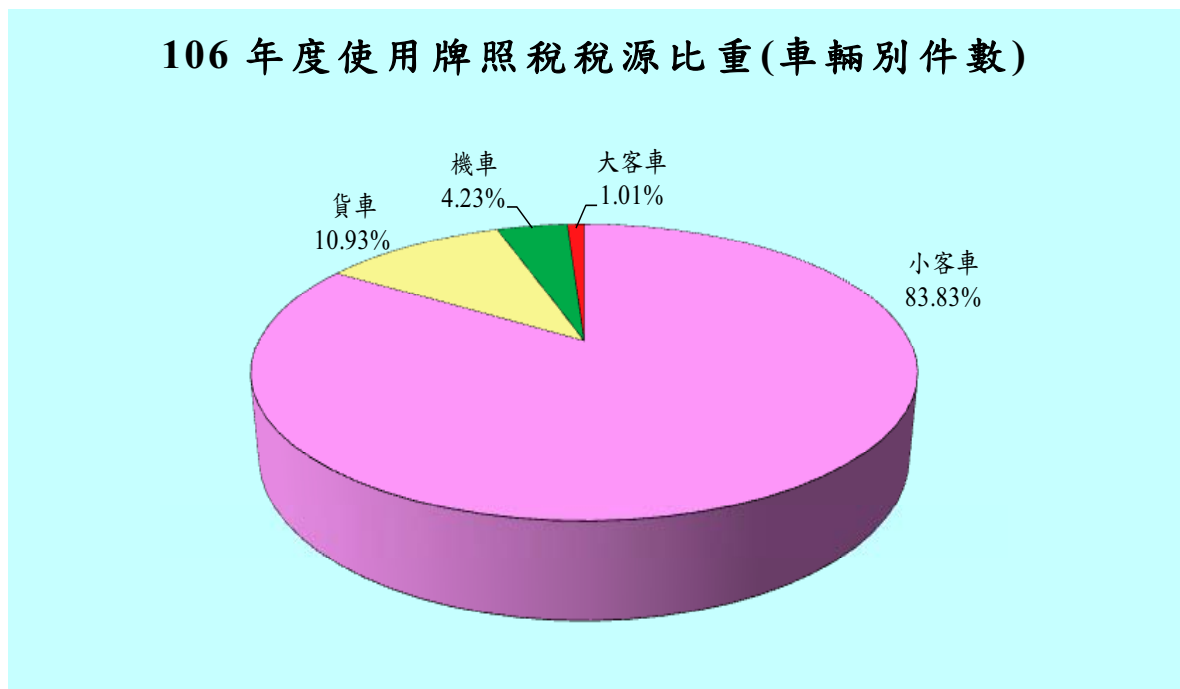
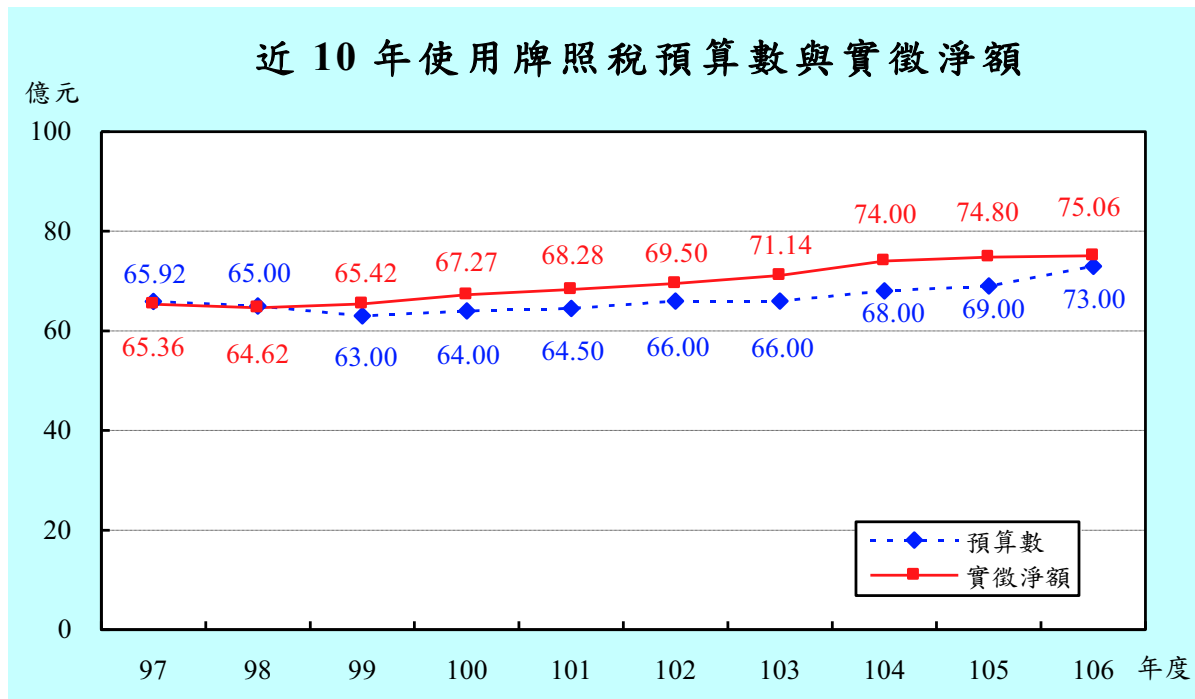

七、契稅

106 年度實徵淨額 15.1 億元，與預算數 18 億元比較，減少 2.9 億元，短徵 16.1%；較上年度實徵淨額 15.72 億元減少 0.62 億元，負成長 3.9%。

106 年度因適用新標準單價房屋調降房屋稅基，該類房屋之契價亦隨之調降，致稅收短徵且較上年度減少。

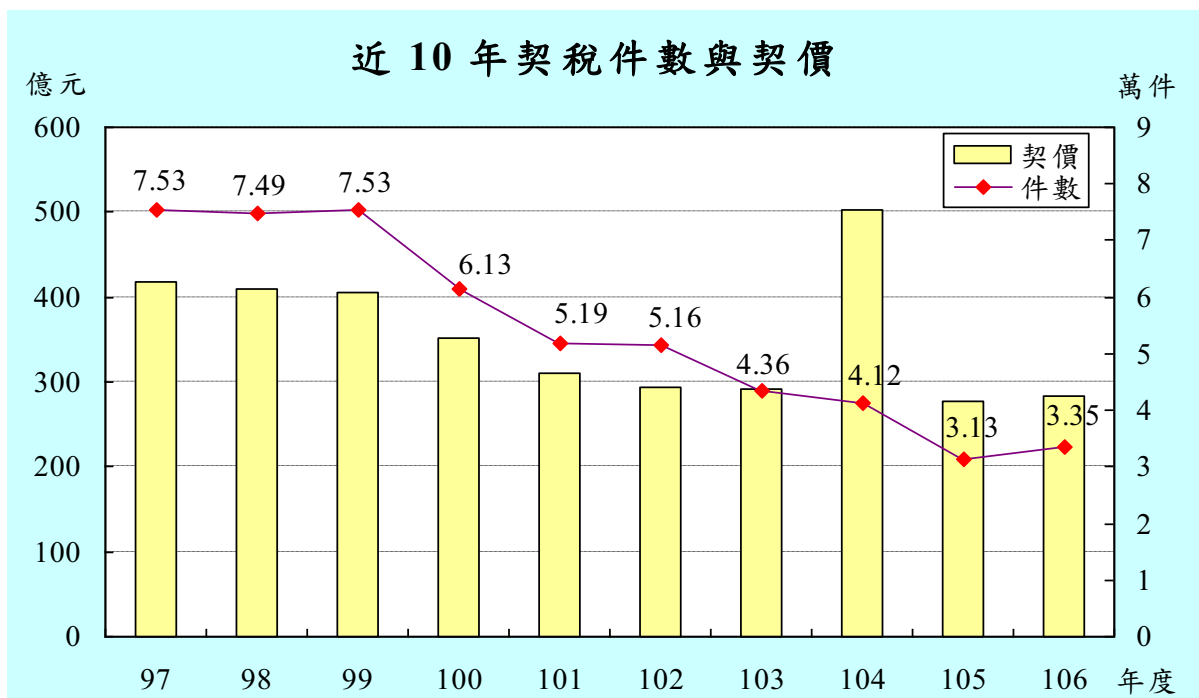
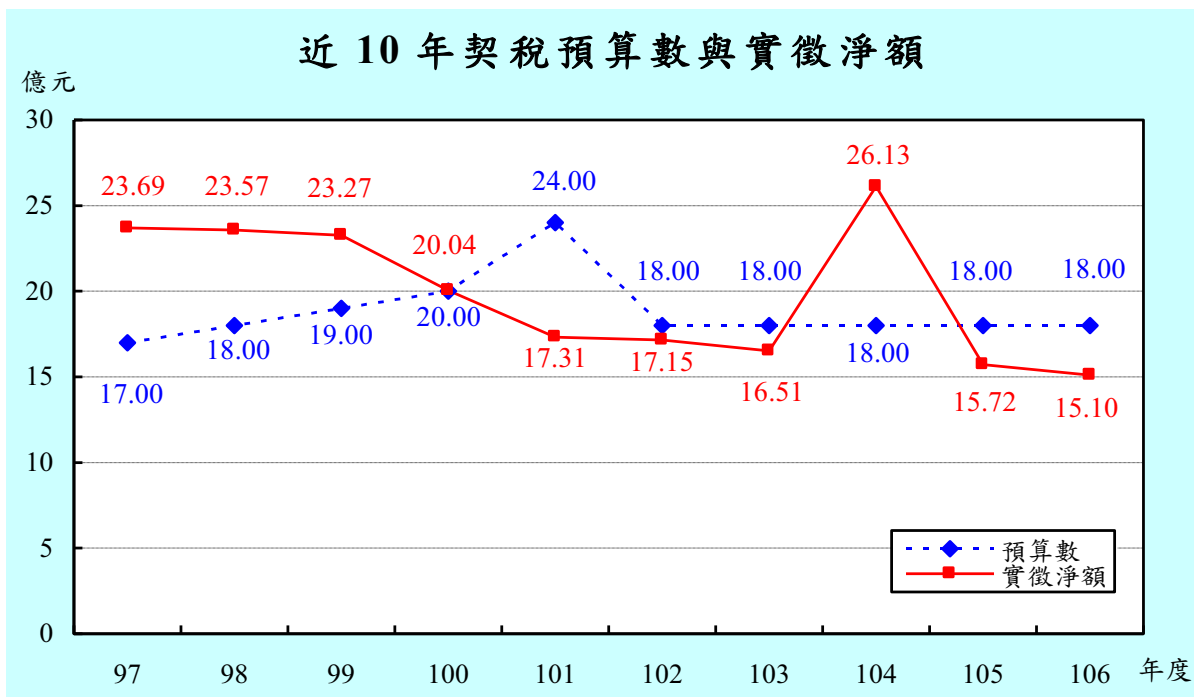

八、印花稅

106 年度實徵淨額 45.79 億元，與預算數 44 億元比較，增加 1.79 億元，超徵 4.1%；較上年度實徵淨額 44.94 億元增加 0.85 億元，成長 1.9%。

106 年度因執行印花稅應稅憑證檢查作業及積極輔導納稅義務人依法繳納印花稅，致稅收超徵且較上年度增加。

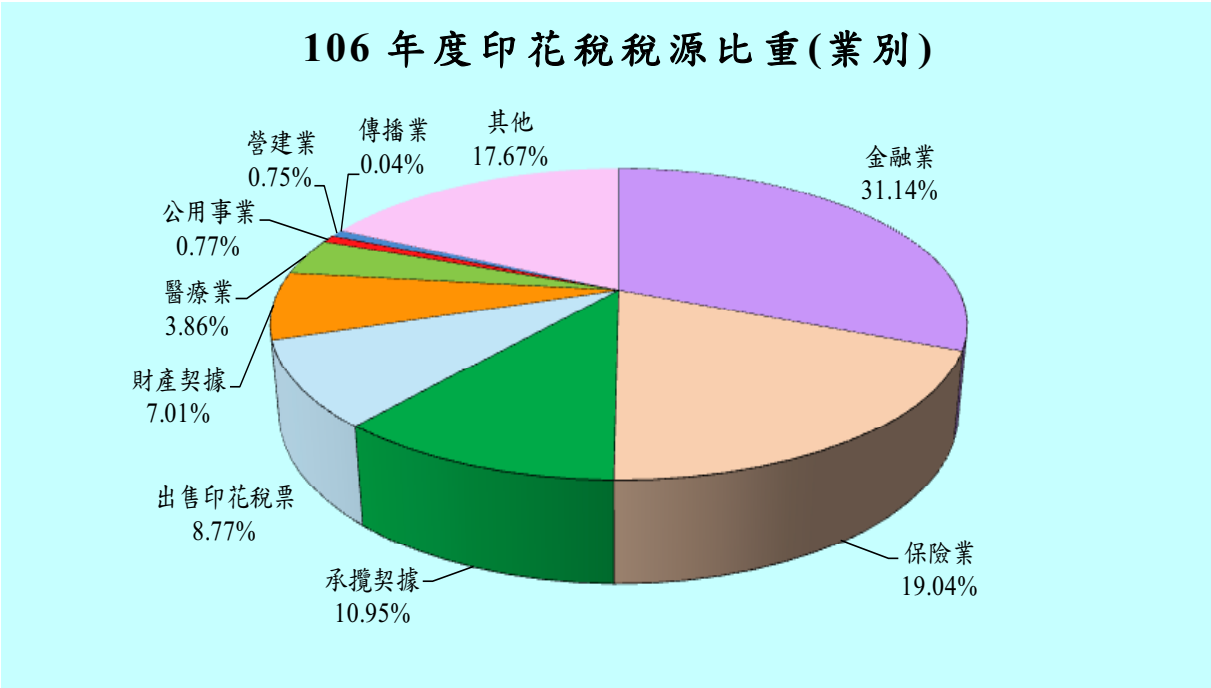
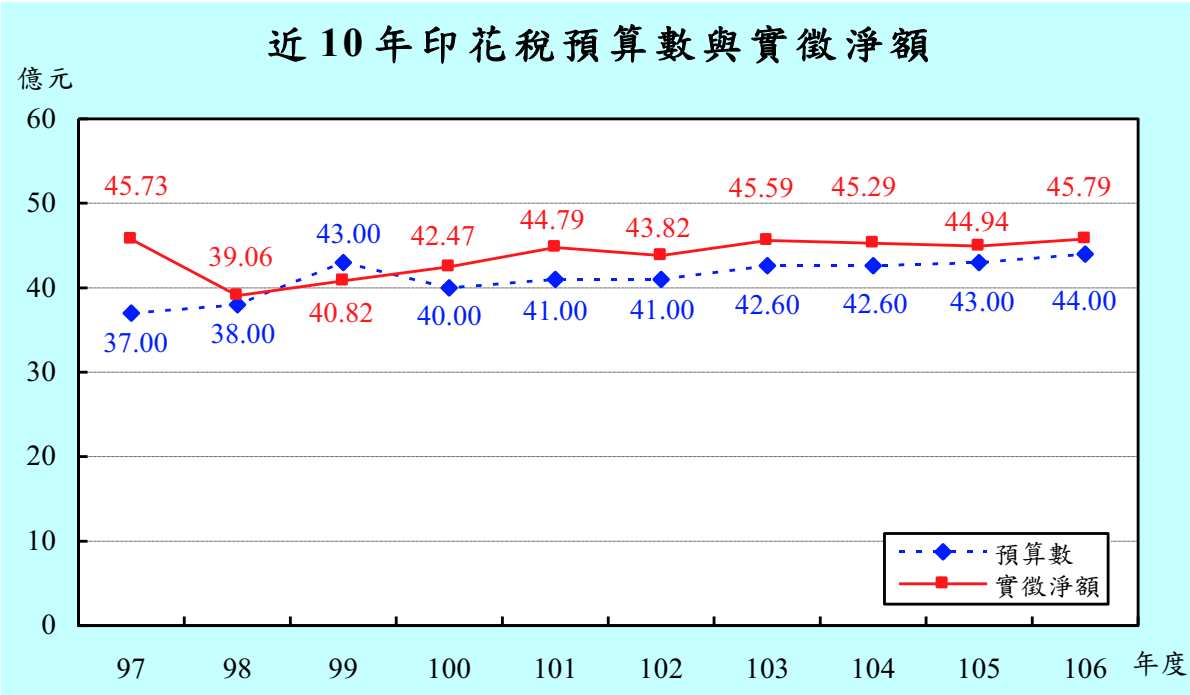

九、娛樂稅

106 年度實徵淨額 2.56 億元，與預算數 2.3 億元比較，增加 0.26 億元，超徵 11.4%；較上年度實徵淨額 2.38 億元增加 0.18 億元，成長 7.7%。

106 年度因臨時性娛樂活動較預期增多，致稅收超徵且較上年度增加。

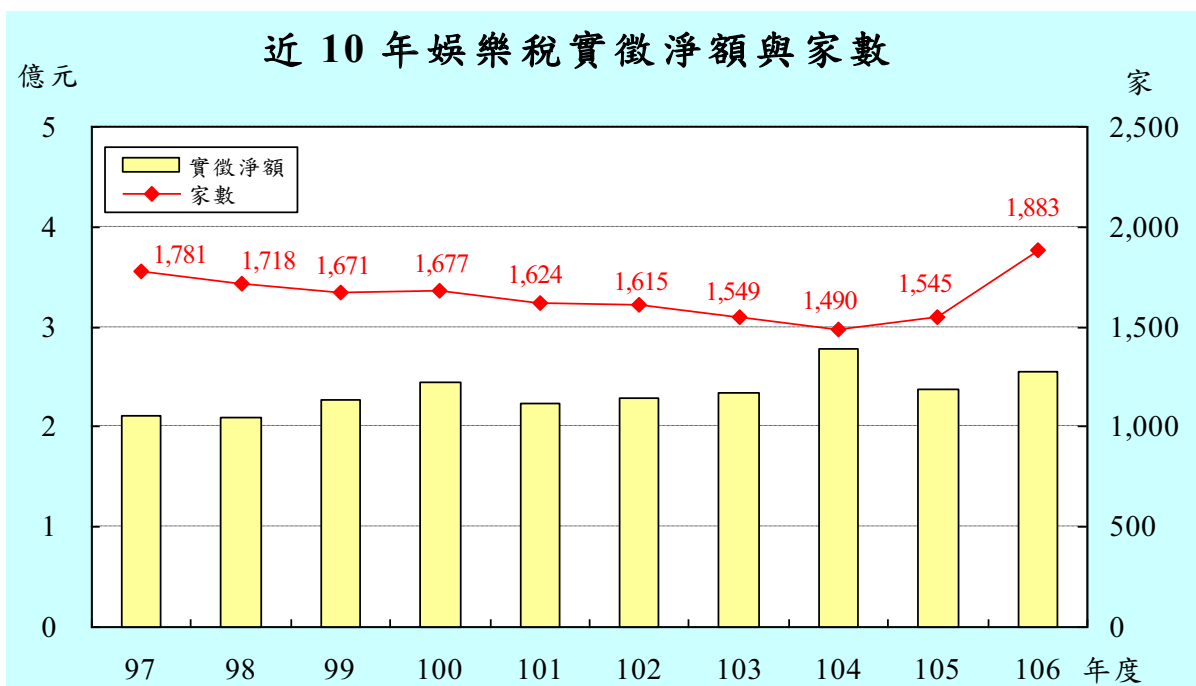
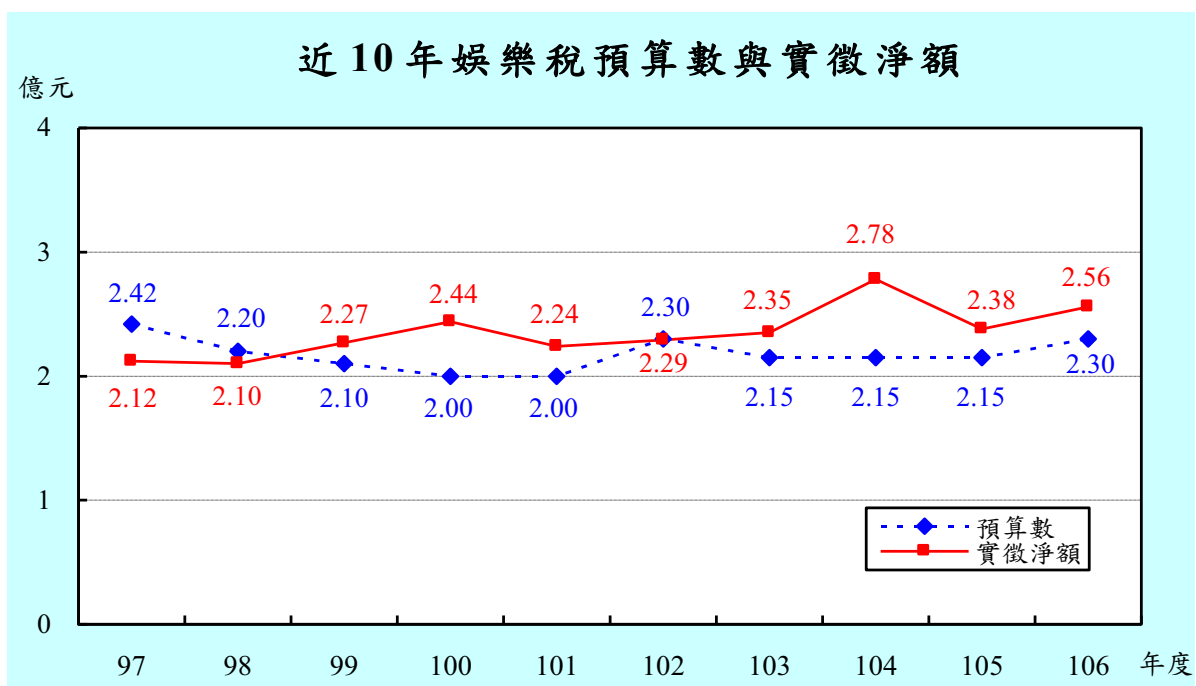

貳、稅收統計

II . Tax Revenue Statistics

表 1 各項稅捐徵績比較

單位：新臺幣元

稅目別 Item of Tax	106 年 度			
	預算數 Budget Amount	查定數① Audited Amount	實徵數② Actual Collection	退還以前 年度歲入款 Tax Income Returned
總 計 Grand Total	75,112,000,000	78,516,005,877	75,368,503,602	376,250,693
稅 課 收 入 Revenues from Taxes	75,014,000,000	78,126,006,033	75,257,918,192	369,058,135
地 價 稅 Land Value Tax	28,784,000,000	31,076,070,002	29,837,828,096	41,814,851
土 地 增 值 稅 Land Value Increment Tax	18,600,000,000	16,891,442,654	15,868,966,932	252,906,867
房 屋 稅 House Tax	13,900,000,000	15,878,783,473	15,687,184,947	61,577,451
使 用 牌 照 稅 Vehicle License Tax	7,300,000,000	7,859,805,423	7,509,640,047	3,868,134
契 稅 Deed Tax	1,800,000,000	1,540,948,039	1,514,720,163	4,214,800
印 花 稅 Stamp Tax	4,400,000,000	4,608,481,500	4,582,909,637	4,189,004
娛 樂 稅 Amusement Tax	230,000,000	270,417,166	256,668,370	487,028
教 育 捐 Education Surtax	—	57,776	—	—
工 程 受 益 費 Construction Benefit Fee	—	—	—	—
罰 鍰 收 入 Punitive Fine Revenue	98,000,000	389,999,844	110,585,410	7,192,558
規 費 收 入 Fees Revenue	—	—	—	—
契 稅 監 證 費 Fees	—	—	—	—

資料來源：依據徵課會計報告編製。

附 註：①查定數包括以前年度結轉數。

②實徵數未含實物抵繳稅款(以遞延收入入帳)。

Table 1. Net Tax Revenues Compare

Unit : N.T.\$1

FY 2017			106 年度與 105 年度比較 Compare FY2017 with FY2016		
實徵淨額 Net Actual Collection	實徵數 占預算數 % Actual Collection/ Budget Amount	實徵淨額 占預算數 % Net Actual Collection/ Budget Amount	105 年度 實徵淨額 Net Actual Collection FY 2016	增減數 Amount	增減 %
74,992,252,909	100.3	99.8	75,409,660,451	-417,407,542	-0.6
74,888,860,057	100.3	99.8	75,321,811,212	-432,951,155	-0.6
29,796,013,245	103.7	103.5	29,495,539,580	300,473,665	1.0
15,616,060,065	85.3	84.0	16,769,323,140	-1,153,263,075	-6.9
15,625,607,496	112.9	112.4	15,272,553,963	353,053,533	2.3
7,505,771,913	102.9	102.8	7,480,159,958	25,611,955	0.3
1,510,505,363	84.2	83.9	1,572,258,852	-61,753,489	-3.9
4,578,720,633	104.2	104.1	4,494,029,348	84,691,285	1.9
256,181,342	111.6	111.4	237,942,933	18,238,409	7.7
—	--	--	3,438	-3,438	--
—	--	--	—	—	--
103,392,852	112.8	105.5	87,849,239	15,543,613	17.7
—	--	--	—	—	--
—	--	--	—	—	--

表 2 歷年各項稅捐預算數、查定數與實徵數

(一)總計①

單位：新臺幣元

年度(月)別 Fiscal Year (Month)	預算數 Budget Amount (A)	查定數 Audited Amount		
		合計 Total	本年度 Current FY	以前年度② Previous FY
97 年度 FY 2008	54,238,000,000	63,451,419,838	57,508,965,836	5,942,454,002
98 年度 FY 2009	53,721,000,000	62,756,930,153	57,011,890,023	5,745,040,130
99 年度 FY 2010	52,865,000,000	65,873,934,825	61,521,291,170	4,352,643,655
100 年度 FY 2011	56,422,260,000	65,754,247,039	61,847,950,043	3,906,296,996
101 年度 FY 2012	61,185,000,000	65,905,662,486	62,733,494,186	3,172,168,300
102 年度 FY 2013	60,561,000,000	69,598,903,684	66,719,824,179	2,879,079,505
103 年度 FY 2014	63,179,000,000	70,613,134,428	67,876,534,672	2,736,599,756
104 年度 FY 2015	65,189,000,000	80,029,271,522	77,287,400,028	2,741,871,494
105 年度 FY 2016	71,652,000,000	78,999,201,336	76,240,367,240	2,758,834,096
106 年度 FY 2017	75,112,000,000	78,516,005,877	75,465,418,591	3,050,587,286
1 月 Jan.	2,776,554,000	5,927,310,870	2,824,922,724	3,102,388,146
2 月 Feb.	1,386,833,000	1,369,944,798	1,387,363,959	- 17,419,161
3 月 Mar.	2,931,700,000	2,828,025,030	2,844,864,620	- 16,839,590
4 月 Apr.	4,945,705,000	7,865,572,395	7,864,461,362	1,111,033
5 月 May	13,384,751,000	17,422,945,450	17,488,071,935	- 65,126,485
6 月 June	6,412,974,000	1,883,405,664	1,873,250,559	10,155,105
7 月 July	2,380,392,000	2,013,112,592	1,986,845,992	26,266,600
8 月 Aug.	2,214,087,000	1,703,986,104	1,682,229,810	21,756,294
9 月 Sep.	2,222,397,000	2,003,392,102	2,021,647,474	- 18,255,372
10 月 Oct.	2,103,412,000	2,193,908,108	2,188,893,126	5,014,982
11 月 Nov.	16,809,959,000	30,881,338,876	30,878,596,364	2,742,512
12 月 Dec.	17,543,236,000	2,423,063,888	2,424,270,666	- 1,206,778

附註：①總計=稅課收入+工程受益費+罰鍰收入+規費收入(監證費)。

②包括以前年度結轉數。

③99年度起實徵數未含實物抵繳稅款(以遞延收入入帳)。

Table 2. Budget Amount, Audited Amount and Actual Collection
in Recent Years

(I) Grand Total ①

Unit : N.T.\$1

實 徵 數 Actual Collection ③			退還以前年度 歲入款 Tax Income Returned (4)	實徵淨額 Net Actual Collection (1-4=5)	實徵淨額 占預算數 % Net Actual Collection /Budge Amount (5/A)×100
合 計 Total (2+3=1)	本 年 度 Current FY (2)	以 前 年 度 Previous FY (3)			
57,349,343,608	55,240,378,164	2,108,965,444	595,865,819	56,753,477,789	104.6
57,906,303,509	55,585,418,083	2,320,885,426	408,280,057	57,498,023,452	107.0
61,412,898,686	59,915,978,897	1,496,919,789	507,663,766	60,905,234,920	115.2
62,364,742,945	60,525,743,015	1,838,999,930	205,300,912	62,159,442,033	110.2
62,751,393,789	61,392,970,041	1,358,423,748	444,487,791	62,306,905,998	101.8
66,673,882,137	65,467,820,238	1,206,061,899	233,351,037	66,440,531,100	109.7
67,721,827,234	66,736,988,776	984,838,458	328,817,075	67,393,010,159	106.7
77,243,428,036	76,180,207,363	1,063,220,673	325,010,445	76,918,417,591	118.0
75,770,755,206	74,606,116,613	1,164,638,593	361,094,755	75,409,660,451	105.2
75,368,503,602	73,939,299,085	1,429,204,517	376,250,693	74,992,252,909	99.8
2,977,961,821	2,404,322,941	573,638,880	144,896,691	2,833,065,130	102.0
1,604,196,768	1,381,583,729	222,613,039	29,866,901	1,574,329,867	113.5
3,028,565,136	2,901,394,717	127,170,419	29,771,827	2,998,793,309	102.3
5,073,082,965	4,946,747,205	126,335,760	19,272,008	5,053,810,957	102.2
13,594,166,685	13,536,788,543	57,378,142	61,106,445	13,533,060,240	101.1
8,046,170,303	7,964,815,567	81,354,736	16,385,218	8,029,785,085	125.2
2,198,915,750	2,138,884,669	60,031,081	8,250,733	2,190,665,017	92.0
1,793,445,376	1,748,784,279	44,661,097	10,768,465	1,782,676,911	80.5
2,269,580,894	2,243,048,866	26,532,028	20,129,348	2,249,451,546	101.2
1,936,335,359	1,911,757,796	24,577,563	9,256,815	1,927,078,544	91.6
18,104,020,128	18,074,524,781	29,495,347	12,407,970	18,091,612,158	107.6
14,742,062,417	14,686,645,992	55,416,425	14,138,272	14,727,924,145	84.0

表 2 歷年各項稅捐預算數、查定數與實徵數 (續1)

(二)稅課收入

1. 合計

單位：新臺幣元

年度(月)別 Fiscal Year (Month)	預算數 Budget Amount (A)	查定數 Audited Amount		
		合計 Total	本年度 Current FY	以前年度 ^① Previous FY
97 年度 FY 2008	54,034,000,000	62,976,080,816	57,346,759,662	5,629,321,154
98 年度 FY 2009	53,520,000,000	62,262,066,305	56,854,450,564	5,407,615,741
99 年度 FY 2010	52,710,000,000	65,326,212,670	61,317,097,584	4,009,115,086
100 年度 FY 2011	56,268,260,000	65,190,790,529	61,714,468,538	3,476,321,991
101 年度 FY 2012	61,050,000,000	65,409,563,052	62,634,837,985	2,774,725,067
102 年度 FY 2013	60,430,000,000	69,105,259,084	66,618,323,432	2,486,935,652
103 年度 FY 2014	63,075,000,000	70,184,841,864	67,802,361,337	2,382,480,527
104 年度 FY 2015	65,075,000,000	79,673,033,591	77,226,086,170	2,446,947,421
105 年度 FY 2016	71,547,000,000	78,640,203,299	76,167,306,395	2,472,896,904
106 年度 FY 2017	75,014,000,000	78,126,006,033	75,383,120,344	2,742,885,689
1 月 Jan.	2,767,193,000	5,653,799,097	2,822,003,701	2,831,795,396
2 月 Feb.	1,381,174,000	1,359,346,255	1,385,486,483	- 26,140,228
3 月 Mar.	2,922,968,000	2,821,092,877	2,841,529,205	- 20,436,328
4 月 Apr.	4,940,945,000	7,857,112,515	7,857,835,208	- 722,693
5 月 May	13,375,173,000	17,409,366,533	17,481,403,008	- 72,036,475
6 月 June	6,402,997,000	1,870,729,120	1,864,140,129	6,588,991
7 月 July	2,372,279,000	1,995,797,753	1,973,144,975	22,652,778
8 月 Aug.	2,205,961,000	1,697,317,162	1,677,766,497	19,550,665
9 月 Sep.	2,217,695,000	1,998,917,348	2,018,337,875	- 19,420,527
10 月 Oct.	2,096,477,000	2,185,962,187	2,182,393,566	3,568,621
11 月 Nov.	16,801,148,000	30,870,710,936	30,869,156,296	1,554,640
12 月 Dec.	17,529,990,000	2,405,854,250	2,409,923,401	-4,069,151

附註：①包括以前年度結轉數。

②99年度起實徵數未含實物抵繳稅款(以遞延收入入帳)。

Table 2. Budget Amount, Audited Amount and Actual Collection
in Recent Years (Cont. 1)

(II) Revenues from Taxes

1. Total

Unit : N.T.\$1

實徵數 Actual Collection ②		退還以前年度 歲入款 Tax Income Returned (4)	實徵淨額 Net Actual Collection (1-4=5)	實徵淨額 占預算數 % Net Actual Collection /Budge Amount (5/A)×100	
合計 Total (2+3=1)	本年度 Current FY (2)				以前年度 Previous FY (3)
57,157,456,189	55,176,188,981	1,981,267,208	586,921,874	56,570,534,315	104.7
57,706,501,696	55,526,927,616	2,179,574,080	361,017,806	57,345,483,890	107.1
61,246,934,737	59,853,800,575	1,393,134,162	402,019,755	60,844,914,982	115.4
62,176,573,002	60,466,079,308	1,710,493,694	177,305,299	61,999,267,703	110.2
62,620,652,883	61,349,810,533	1,270,842,350	431,514,478	62,189,138,405	101.9
66,530,700,040	65,412,535,691	1,118,164,349	219,980,597	66,310,719,443	109.7
67,616,183,545	66,695,912,290	920,271,255	325,059,274	67,291,124,271	106.7
77,142,165,141	76,138,178,495	1,003,986,646	318,801,340	76,823,363,801	118.1
75,678,277,878	74,562,224,169	1,116,053,709	356,466,666	75,321,811,212	105.3
75,257,918,192	73,885,767,803	1,372,150,389	369,058,135	74,888,860,057	99.8
2,970,823,886	2,402,754,604	568,069,282	144,296,436	2,826,527,450	102.1
1,593,139,504	1,380,362,480	212,777,024	29,619,716	1,563,519,788	113.2
3,022,582,974	2,900,404,070	122,178,904	28,927,217	2,993,655,757	102.4
5,068,492,639	4,944,963,088	123,529,551	18,661,281	5,049,831,358	102.2
13,581,297,744	13,532,167,775	49,129,969	59,678,776	13,521,618,968	101.1
8,033,837,264	7,957,857,093	75,980,171	16,186,252	8,017,651,012	125.2
2,187,562,807	2,132,813,249	54,749,558	8,016,192	2,179,546,615	91.9
1,786,641,368	1,745,884,395	40,756,973	9,861,433	1,776,779,935	80.5
2,263,722,897	2,239,792,548	23,930,349	19,759,357	2,243,963,540	101.2
1,930,381,274	1,908,123,236	22,258,038	8,445,494	1,921,935,780	91.7
18,097,187,090	18,069,908,353	27,278,737	11,839,271	18,085,347,819	107.6
14,722,248,745	14,670,736,912	51,511,833	13,766,710	14,708,482,035	83.9

表 2 歷年各項稅捐預算數、查定數與實徵數 (續2)

(二)稅課收入

2. 地價稅

單位：新臺幣元

年度(月)別 Fiscal Year (Month)	預算數 Budget Amount (A)	查定數 Audited Amount		
		合計 Total	本年度 Current FY	以前年度 Previous FY
97 年度 FY 2008	17,600,000,000	21,622,348,590	18,962,431,757	2,659,916,833
98 年度 FY 2009	17,800,000,000	20,775,773,127	18,637,378,171	2,138,394,956
99 年度 FY 2010	18,000,000,000	22,108,091,007	20,315,591,574	1,792,499,433
100 年度 FY 2011	18,400,000,000	21,729,735,988	20,213,024,931	1,516,711,057
101 年度 FY 2012	19,500,000,000	21,916,615,715	20,793,949,827	1,122,665,888
102 年度 FY 2013	21,900,000,000	23,134,506,730	22,091,728,224	1,042,778,506
103 年度 FY 2014	21,200,000,000	23,465,985,406	22,555,658,532	910,326,874
104 年度 FY 2015	21,800,000,000	23,120,367,032	22,199,044,067	921,322,965
105 年度 FY 2016	26,732,000,000	30,901,381,720	29,936,501,857	964,879,863
106 年度 FY 2017	28,784,000,000	31,076,070,002	29,772,493,181	1,303,576,821
1 月 Jan.	92,702,000	1,339,412,836	11,907,753	1,327,505,083
2 月 Feb.	26,402,000	2,450,660	2,339,747	110,913
3 月 Mar.	41,164,000	179,068,692	179,308,326	- 239,634
4 月 Apr.	48,928,000	38,079,877	38,796,863	- 716,986
5 月 May	31,328,000	18,532,488	18,965,780	- 433,292
6 月 June	39,018,000	6,202,328	6,630,577	- 428,249
7 月 July	27,648,000	12,179,659	12,171,738	7,921
8 月 Aug.	28,203,000	15,108,148	15,018,521	89,627
9 月 Sep.	65,891,000	7,102,337	25,378,976	- 18,276,639
10 月 Oct.	230,515,000	474,202,972	474,046,047	156,925
11 月 Nov.	13,918,511,000	28,249,483,553	28,248,962,228	521,325
12 月 Dec.	14,233,690,000	734,246,452	738,966,625	- 4,720,173

Table 2. Budget Amount, Audited Amount and Actual Collection
in Recent Years (Cont. 2)

(II) Revenues from Taxes

2. Land Value Tax

Unit : N.T.\$1

實徵數 Actual Collection			退還以前年度 歲入款 Tax Income Returned (4)	實徵淨額 Net Actual Collection (1-4=5)	實徵淨額 占預算數 % Net Actual Collection /Budge Amount (5/A)×100
合計 Total (2+3=1)	本年度 Current FY (2)	以前年度 Previous FY (3)			
19,336,852,287	18,205,651,270	1,131,201,017	148,458,460	19,188,393,827	109.0
18,836,109,030	18,029,123,615	806,985,415	133,715,429	18,702,393,601	105.1
20,332,765,697	19,623,815,795	708,949,902	41,724,158	20,291,041,539	112.7
20,534,137,009	19,743,790,367	790,346,642	28,928,504	20,505,208,505	111.4
20,748,021,644	20,243,111,064	504,910,580	77,497,739	20,670,523,905	106.0
22,143,481,947	21,644,233,803	499,248,144	57,150,883	22,086,331,064	100.9
22,520,360,611	22,125,335,251	395,025,360	72,405,760	22,447,954,851	105.9
22,089,792,483	21,715,846,880	373,945,603	49,642,280	22,040,150,203	101.1
29,519,660,662	29,085,483,331	434,177,331	24,121,082	29,495,539,580	110.3
29,837,828,096	29,173,528,221	664,299,875	41,814,851	29,796,013,245	103.5
188,544,383	10,637,703	177,906,680	13,495,273	175,049,110	188.8
174,104,965	1,612,183	172,492,782	3,673,504	170,431,461	645.5
260,612,636	170,125,073	90,487,563	4,170,748	256,441,888	623.0
106,916,390	12,101,041	94,815,349	1,683,705	105,232,685	215.1
68,505,033	34,496,398	34,008,635	1,267,246	67,237,787	214.6
33,511,937	14,023,258	19,488,679	1,241,520	32,270,417	82.7
33,252,664	13,932,060	19,320,604	260,584	32,992,080	119.3
30,323,661	14,450,583	15,873,078	4,246,569	26,077,092	92.5
32,821,038	23,527,794	9,293,244	3,150,417	29,670,621	45.0
488,741,141	479,849,608	8,891,533	828,783	487,912,358	211.7
15,522,806,188	15,512,987,109	9,819,079	4,007,037	15,518,799,151	111.5
12,897,688,060	12,885,785,411	11,902,649	3,789,465	12,893,898,595	90.6

表 2 歷年各項稅捐預算數、查定數與實徵數 (續3)

(二)稅課收入

3. 土地增值稅

單位：新臺幣元

年度(月)別 Fiscal Year (Month)	預算數 Budget Amount (A)	查定數 Audited Amount		
		合計 Total	本年度 Current FY	以前年度 Previous FY
97 年度 FY 2008	14,400,000,000	15,838,196,306	14,501,930,736	1,336,265,570
98 年度 FY 2009	13,500,000,000	16,754,143,332	14,953,917,653	1,800,225,679
99 年度 FY 2010	12,000,000,000	18,231,273,864	17,212,755,478	1,018,518,386
100 年度 FY 2011	15,000,000,000	18,530,330,855	17,550,051,311	980,279,544
101 年度 FY 2012	17,000,000,000	17,566,789,041	16,633,841,191	932,947,850
102 年度 FY 2013	14,200,000,000	20,013,739,423	19,214,772,442	798,966,981
103 年度 FY 2014	17,000,000,000	20,373,582,528	19,505,216,701	868,365,827
104 年度 FY 2015	17,600,000,000	26,935,057,700	25,913,549,898	1,021,507,802
105 年度 FY 2016	18,200,000,000	17,991,803,151	17,041,289,028	950,514,123
106 年度 FY 2017	18,600,000,000	16,891,442,654	16,105,230,681	786,211,973
1 月 Jan.	1,737,240,000	2,731,264,835	1,839,410,024	891,854,811
2 月 Feb.	1,084,380,000	1,081,474,039	1,107,211,977	- 25,737,938
3 月 Mar.	1,670,280,000	1,313,688,777	1,333,489,918	- 19,801,141
4 月 Apr.	1,073,220,000	1,221,908,225	1,221,461,846	446,379
5 月 May	1,454,520,000	1,339,816,573	1,404,873,679	- 65,057,106
6 月 June	1,300,140,000	1,245,590,770	1,249,576,439	- 3,985,669
7 月 July	1,342,920,000	1,108,364,782	1,108,364,782	—
8 月 Aug.	1,731,660,000	1,375,736,149	1,369,611,807	6,124,342
9 月 Sep.	1,242,480,000	1,192,948,221	1,190,272,846	2,675,375
10 月 Oct.	1,421,040,000	1,088,852,068	1,088,036,319	815,749
11 月 Nov.	1,733,520,000	1,771,462,263	1,771,683,047	- 220,784
12 月 Dec.	2,808,600,000	1,420,335,952	1,421,237,997	-902,045

Table 2. Budget Amount, Audited Amount and Actual Collection
in Recent Years (Cont. 3)

(II) Revenues from Taxes

3. Land Value Increment Tax

Unit : N.T.\$1

實徵數 Actual Collection			退還以前年度 歲入款 Tax Income Returned (4)	實徵淨額 Net Actual Collection (1-4=5)	實徵淨額 占預算數 % Net Actual Collection /Budge Amount (5/A)×100
合計 Total (2+3=1)	本年度 Current FY (2)	以前年度 Previous FY (3)			
13,943,736,263	13,477,042,093	466,694,170	394,326,670	13,549,409,593	94.1
15,609,940,194	14,555,621,276	1,054,318,918	196,024,352	15,413,915,842	114.2
17,088,982,865	16,718,462,793	370,520,072	204,092,581	16,884,890,284	140.7
17,528,534,334	16,992,903,207	535,631,127	121,268,101	17,407,266,233	116.0
16,674,777,843	16,137,848,941	536,928,902	277,563,791	16,397,214,052	96.5
19,103,840,213	18,728,768,054	375,072,159	131,046,359	18,972,793,854	133.6
19,303,115,028	19,066,215,194	236,899,834	236,107,832	19,067,007,196	112.2
26,011,486,168	25,568,874,128	442,612,040	243,621,242	25,767,864,926	146.4
17,030,416,543	16,552,918,087	477,498,456	261,093,403	16,769,323,140	92.1
15,868,966,932	15,458,249,801	410,717,131	252,906,867	15,616,060,065	84.0
1,798,045,617	1,486,663,226	311,382,391	117,681,067	1,680,364,550	96.7
1,116,558,091	1,095,084,993	21,473,098	21,567,040	1,094,991,051	101.0
1,410,688,203	1,395,124,540	15,563,663	20,434,427	1,390,253,776	83.2
1,177,971,600	1,161,410,796	16,560,804	13,555,447	1,164,416,153	108.5
1,283,341,756	1,279,893,272	3,448,484	16,189,126	1,267,152,630	87.1
1,355,826,222	1,344,165,912	11,660,310	14,205,156	1,341,621,066	103.2
1,070,539,677	1,069,524,547	1,015,130	7,108,956	1,063,430,721	79.2
1,339,513,538	1,335,263,598	4,249,940	5,377,721	1,334,135,817	77.0
1,337,253,879	1,332,337,702	4,916,177	16,165,247	1,321,088,632	106.3
1,075,364,311	1,070,524,882	4,839,429	6,647,829	1,068,716,482	75.2
1,394,231,437	1,383,874,258	10,357,179	4,281,640	1,389,949,797	80.2
1,509,632,601	1,504,382,075	5,250,526	9,693,211	1,499,939,390	53.4

表 2 歷年各項稅捐預算數、查定數與實徵數 (續4)

(二)稅課收入

4. 房屋稅

單位：新臺幣元

年度(月)別 Fiscal Year (Month)	預算數 Budget Amount (A)	查定數 Audited Amount		
		合計 Total	本年度 Current FY	以前年度 Previous FY
97 年度 FY 2008	9,800,000,000	11,078,405,809	10,126,254,227	952,151,582
98 年度 FY 2009	9,900,000,000	11,165,748,863	10,287,985,782	877,763,081
99 年度 FY 2010	10,000,000,000	11,216,744,220	10,584,535,806	632,208,414
100 年度 FY 2011	10,268,260,000	11,195,589,644	10,724,497,031	471,092,613
101 年度 FY 2012	11,400,000,000	12,145,931,799	11,853,364,805	292,566,994
102 年度 FY 2013	11,600,000,000	12,242,328,975	11,981,068,357	261,260,618
103 年度 FY 2014	12,000,000,000	12,425,932,774	12,183,993,065	241,939,709
104 年度 FY 2015	12,600,000,000	14,438,403,941	14,239,602,056	198,801,885
105 年度 FY 2016	13,400,000,000	15,548,887,181	15,318,647,735	230,239,446
106 年度 FY 2017	13,900,000,000	15,878,783,473	15,669,043,618	209,739,855
1 月 Jan.	26,410,000	240,178,332	19,991,620	220,186,712
2 月 Feb.	12,510,000	18,269,946	18,404,297	- 134,351
3 月 Mar.	25,020,000	43,113,991	43,156,612	- 42,621
4 月 Apr.	301,630,000	353,785,093	353,813,433	- 28,340
5 月 May	8,565,180,000	14,808,711,559	14,808,789,664	- 78,105
6 月 June	4,681,520,000	342,714,147	343,236,066	- 521,919
7 月 July	55,600,000	460,433	461,941	- 1,508
8 月 Aug.	55,600,000	13,419,131	13,384,208	34,923
9 月 Sep.	56,990,000	-3,434,454	3,122,200	- 6,556,654
10 月 Oct.	77,840,000	23,235,249	23,144,750	90,499
11 月 Nov.	26,410,000	25,087,249	25,229,613	- 142,364
12 月 Dec.	15,290,000	13,242,797	16,309,214	- 3,066,417

Table 2. Budget Amount, Audited Amount and Actual Collection
in Recent Years (Cont. 4)

(II) Revenues from Taxes

4. House Tax

Unit : N.T.\$1

實徵數 Actual Collection			退還以前年度 歲入款 Tax Income Returned (4)	實徵淨額 Net Actual Collection (1-4=5)	實徵淨額 占預算數 % Net Actual Collection /Budge Amount (5/A)×100
合計 Total (2+3=1)	本年度 Current FY (2)	以前年度 Previous FY (3)			
10,147,929,725	9,971,769,272	176,160,453	7,309,474	10,140,620,251	103.5
10,307,459,162	10,167,653,129	139,806,033	11,972,825	10,295,486,337	104.0
10,627,295,631	10,486,926,494	140,369,137	126,758,102	10,500,537,529	105.0
10,873,867,433	10,640,949,149	232,918,284	8,744,070	10,865,123,363	105.8
11,869,544,305	11,765,750,542	103,793,763	9,609,521	11,859,934,784	104.0
11,997,380,436	11,884,758,971	112,621,465	21,333,121	11,976,047,315	103.2
12,221,541,822	12,093,853,815	127,688,007	4,407,746	12,217,134,076	101.8
14,203,137,405	14,137,990,927	65,146,478	8,028,056	14,195,109,349	112.7
15,328,339,244	15,236,454,042	91,885,202	55,785,281	15,272,553,963	114.0
15,687,184,947	15,592,900,040	94,284,907	61,577,451	15,625,607,496	112.4
32,135,564	15,419,141	16,716,423	9,765,373	22,370,191	84.7
22,169,383	16,079,703	6,089,680	3,920,628	18,248,755	145.9
46,528,902	42,278,619	4,250,283	1,949,718	44,579,184	178.2
357,988,979	354,576,898	3,412,081	1,815,811	356,173,168	118.1
8,589,430,006	8,587,252,082	2,177,924	41,877,933	8,547,552,073	99.8
6,275,829,833	6,250,646,047	25,183,786	599,170	6,275,230,663	134.0
106,307,233	103,912,700	2,394,533	366,066	105,941,167	190.5
49,814,192	47,325,220	2,488,972	106,415	49,707,777	89.4
53,653,690	52,269,261	1,384,429	198,231	53,455,459	93.8
64,398,976	62,779,498	1,619,478	403,862	63,995,114	82.2
36,893,339	35,144,819	1,748,520	426,367	36,466,972	138.1
52,034,850	25,216,052	26,818,798	147,877	51,886,973	339.4

表 2 歷年各項稅捐預算數、查定數與實徵數 (續5)

(二)稅課收入

5. 使用牌照稅

單位：新臺幣元

年度(月)別 Fiscal Year (Month)	預算數 Budget Amount (A)	查定數 Audited Amount		
		合計 Total	本年度 Current FY	以前年度 Previous FY
97 年度 FY 2008	6,592,000,000	7,146,127,212	6,566,865,409	579,261,803
98 年度 FY 2009	6,500,000,000	7,003,421,917	6,486,376,074	517,045,843
99 年度 FY 2010	6,300,000,000	7,057,513,192	6,557,727,685	499,785,507
100 年度 FY 2011	6,400,000,000	7,172,227,550	6,720,258,884	451,968,666
101 年度 FY 2012	6,450,000,000	7,210,013,827	6,833,694,476	376,319,351
102 年度 FY 2013	6,600,000,000	7,286,652,627	6,966,480,016	320,172,611
103 年度 FY 2014	6,600,000,000	7,407,801,179	7,137,466,677	270,334,502
104 年度 FY 2015	6,800,000,000	7,689,616,970	7,436,140,040	253,476,930
105 年度 FY 2016	6,900,000,000	7,810,668,145	7,525,219,941	285,448,204
106 年度 FY 2017	7,300,000,000	7,859,805,423	7,542,552,703	317,252,720
1 月 Jan.	116,130,000	438,416,411	112,057,499	326,358,912
2 月 Feb.	79,378,000	80,764,920	80,418,403	346,517
3 月 Mar.	425,245,000	467,686,478	467,653,050	33,428
4 月 Apr.	3,331,420,000	5,997,702,826	5,998,758,857	- 1,056,031
5 月 May	2,560,072,000	418,880,905	427,576,263	- 8,695,358
6 月 June	97,853,000	5,082,964	5,827,023	- 744,059
7 月 July	104,189,000	21,599,911	21,579,353	20,558
8 月 Aug.	90,264,000	20,502,572	20,437,059	65,513
9 月 Sep.	38,925,000	10,979,574	10,851,159	128,415
10 月 Oct.	116,219,000	384,134,528	383,634,511	500,017
11 月 Nov.	315,956,000	13,076,005	12,926,573	149,432
12 月 Dec.	24,349,000	978,329	832,953	145,376

Table 2. Budget Amount, Audited Amount and Actual Collection
in Recent Years (Cont. 5)

(II) Revenues from Taxes

5. Vehicle License Tax

Unit : N.T.\$1

實徵數 Actual Collection			退還以前年度 歲入款 Tax Income Returned	實徵淨額 Net Actual Collection	實徵淨額 占預算數 % Net Actual Collection /Budge Amount (5/A)×100
合計 Total (2+3=1)	本年度 Current FY (2)	以前年度 Previous FY (3)			
6,557,721,371	6,391,932,046	165,789,325	21,283,375	6,536,437,996	99.2
6,471,544,379	6,327,495,599	144,048,780	9,534,915	6,462,009,464	99.4
6,555,896,936	6,423,796,664	132,100,272	13,827,036	6,542,069,900	103.8
6,734,678,663	6,623,516,937	111,161,726	7,912,188	6,726,766,475	105.1
6,833,177,948	6,746,233,733	86,944,215	5,451,652	6,827,726,296	105.9
6,955,441,436	6,877,052,975	78,388,461	5,347,283	6,950,094,153	105.3
7,118,817,681	7,040,294,793	78,522,888	4,939,003	7,113,878,678	107.8
7,403,407,388	7,323,486,127	79,921,261	3,706,191	7,399,701,197	108.8
7,484,074,599	7,402,428,814	81,645,785	3,914,641	7,480,159,958	108.4
7,509,640,047	7,420,360,586	89,279,461	3,868,134	7,505,771,913	102.8
116,539,529	103,546,225	12,993,304	1,512,689	115,026,840	99.1
90,441,992	79,321,514	11,120,478	125,477	90,316,515	113.8
477,741,174	465,936,614	11,804,560	134,601	477,606,573	112.3
3,204,750,679	3,196,943,158	7,807,521	1,144,180	3,203,606,499	96.2
2,811,062,111	2,802,920,418	8,141,693	100,168	2,810,961,943	109.8
106,062,876	98,234,866	7,828,010	134,823	105,928,053	108.3
112,429,756	104,221,740	8,208,016	188,945	112,240,811	107.7
97,073,323	91,759,658	5,313,665	76,252	96,997,071	107.5
42,636,810	37,681,977	4,954,833	110,565	42,526,245	109.3
95,090,226	91,108,565	3,981,661	228,113	94,862,113	81.6
335,653,887	331,615,610	4,038,277	40,766	335,613,121	106.2
20,157,684	17,070,241	3,087,443	71,555	20,086,129	82.5

表 2 歷年各項稅捐預算數、查定數與實徵數 (續6)

(二)稅課收入

6. 契稅

單位：新臺幣元

年度(月)別 Fiscal Year (Month)	預算數 Budget Amount (A)	查定數 Audited Amount		
		合計 Total	本年度 Current FY	以前年度 Previous FY
97 年度 FY 2008	1,700,000,000	2,400,691,064	2,376,222,441	24,468,623
98 年度 FY 2009	1,800,000,000	2,387,423,390	2,370,494,063	16,929,327
99 年度 FY 2010	1,900,000,000	2,354,950,169	2,335,370,733	19,579,436
100 年度 FY 2011	2,000,000,000	2,024,703,077	2,004,885,156	19,817,921
101 年度 FY 2012	2,400,000,000	1,801,127,687	1,789,084,593	12,043,094
102 年度 FY 2013	1,800,000,000	1,734,852,208	1,715,325,749	19,526,459
103 年度 FY 2014	1,800,000,000	1,681,135,183	1,666,281,819	14,853,364
104 年度 FY 2015	1,800,000,000	2,635,476,618	2,615,259,099	20,217,519
105 年度 FY 2016	1,800,000,000	1,610,624,175	1,605,091,654	5,532,521
106 年度 FY 2017	1,800,000,000	1,540,948,039	1,518,313,118	22,634,921
1 月 Jan.	131,865,000	173,109,352	149,061,180	24,048,172
2 月 Feb.	92,063,000	79,454,935	79,961,935	- 507,000
3 月 Mar.	148,157,000	158,701,750	159,263,738	- 561,988
4 月 Apr.	93,987,000	150,630,738	150,680,766	- 50,028
5 月 May	117,431,000	151,345,378	151,336,156	9,222
6 月 June	150,697,000	141,647,290	141,639,358	7,932
7 月 July	141,699,000	98,193,165	98,190,747	2,418
8 月 Aug.	152,373,000	116,435,569	116,435,569	—
9 月 Sep.	137,982,000	108,041,951	108,054,383	- 12,432
10 月 Oct.	147,111,000	93,394,190	93,696,986	- 302,796
11 月 Nov.	191,748,000	156,444,309	156,443,800	509
12 月 Dec.	294,887,000	113,549,412	113,548,500	912

Table 2. Budget Amount, Audited Amount and Actual Collection
in Recent Years (Cont. 6)

(II) Revenues from Taxes

6.Deed Tax

Unit : N.T.\$1

實徵數 Actual Collection			退還以前年度 歲入款 Tax Income Returned	實徵淨額 Net Actual Collection	實徵淨額 占預算數 % Net Actual Collection /Budge Amount (5/A)×100
合計 Total (2+3=1)	本年度 Current FY (2)	以前年度 Previous FY (3)			
2,373,419,350	2,355,450,922	17,968,428	4,332,477	2,369,086,873	139.4
2,362,740,281	2,349,557,652	13,182,629	5,738,532	2,357,001,749	130.9
2,331,574,422	2,314,250,777	17,323,645	4,427,193	2,327,147,229	122.5
2,009,354,997	1,990,445,604	18,909,393	5,023,858	2,004,331,139	100.2
1,779,320,448	1,767,832,856	11,487,592	48,554,638	1,730,765,810	72.1
1,718,308,296	1,699,547,000	18,761,296	3,357,047	1,714,951,249	95.3
1,656,050,355	1,641,731,846	14,318,509	5,414,521	1,650,635,834	91.7
2,619,757,703	2,599,963,241	19,794,462	6,636,420	2,613,121,283	145.2
1,582,985,477	1,577,826,873	5,158,604	10,726,625	1,572,258,852	87.3
1,514,720,163	1,492,438,414	22,281,749	4,214,800	1,510,505,363	83.9
143,777,315	121,810,816	21,966,499	855,677	142,921,638	108.4
89,172,006	88,886,119	285,887	243,416	88,928,590	96.6
164,729,003	165,062,077	- 333,074	2,204,566	162,524,437	109.7
130,520,793	130,564,296	-43,503	348,102	130,172,691	138.5
157,520,643	157,510,941	9,702	224,800	157,295,843	133.9
132,921,623	132,816,185	105,438	5,583	132,916,040	88.2
114,305,648	114,256,381	49,267	86,688	114,218,960	80.6
118,976,269	118,970,551	5,718	41,028	118,935,241	78.1
100,069,016	99,967,498	101,518	47,316	100,021,700	72.5
92,433,053	92,361,095	71,958	53,142	92,379,911	62.8
155,115,793	155,056,381	59,412	104,466	155,011,327	80.8
115,179,001	115,176,074	2,927	16	115,178,985	39.1

表 2 歷年各項稅捐預算數、查定數與實徵數 (續7)

(二)稅課收入

7. 印花稅

單位：新臺幣元

年度(月)別 Fiscal Year (Month)	預算數 Budget Amount (A)	查定數 Audited Amount		
		合計 Total	本年度 Current FY	以前年度 Previous FY
97 年度 FY 2008	3,700,000,000	4,609,282,181	4,588,774,708	20,507,473
98 年度 FY 2009	3,800,000,000	3,925,051,668	3,906,121,491	18,930,177
99 年度 FY 2010	4,300,000,000	4,104,312,940	4,082,135,308	22,177,632
100 年度 FY 2011	4,000,000,000	4,276,000,815	4,256,320,858	19,679,957
101 年度 FY 2012	4,100,000,000	4,528,289,507	4,503,633,420	24,656,087
102 年度 FY 2013	4,100,000,000	4,450,816,446	4,420,195,497	30,620,949
103 年度 FY 2014	4,260,000,000	4,582,705,985	4,517,168,088	65,537,897
104 年度 FY 2015	4,260,000,000	4,564,573,534	4,544,318,777	20,254,757
105 年度 FY 2016	4,300,000,000	4,525,491,724	4,500,617,981	24,873,743
106 年度 FY 2017	4,400,000,000	4,608,481,500	4,518,125,272	90,356,228
1 月 Jan.	648,293,000	693,017,960	664,555,047	28,462,913
2 月 Feb.	68,389,000	76,943,453	77,170,730	- 227,277
3 月 Mar.	590,032,000	633,187,572	633,029,129	158,443
4 月 Apr.	76,170,000	77,033,308	76,342,660	690,648
5 月 May	625,780,000	652,603,741	650,385,449	2,218,292
6 月 June	114,105,000	112,205,863	99,944,776	12,261,087
7 月 July	682,856,000	733,955,305	711,329,906	22,625,399
8 月 Aug.	127,887,000	130,074,258	116,839,901	13,234,357
9 月 Sep.	653,671,000	663,567,566	660,728,446	2,839,120
10 月 Oct.	88,250,000	96,161,812	93,857,955	2,303,857
11 月 Nov.	595,952,000	635,169,039	633,852,846	1,316,193
12 月 Dec.	128,615,000	104,561,623	100,088,427	4,473,196

Table 2. Budget Amount, Audited Amount and Actual Collection
in Recent Years (Cont. 7)

(II) Revenues from Taxes

7. Stamp Tax

Unit : N.T.\$1

實徵數 Actual Collection			退還以前年度 歲入款 Tax Income Returned	實徵淨額 Net Actual Collection	實徵淨額 占預算數 % Net Actual Collection /Budge Amount (5/A)×100
合計 Total (2+3=1)	本年度 Current FY (2)	以前年度 Previous FY (3)			
4,575,045,907	4,555,749,565	19,296,342	1,704,717	4,573,341,190	123.6
3,908,255,404	3,890,354,445	17,900,959	2,724,686	3,905,530,718	102.8
4,082,809,119	4,061,562,012	21,247,107	492,895	4,082,316,224	94.9
4,251,545,414	4,232,189,023	19,356,391	4,783,867	4,246,761,547	106.2
4,490,891,015	4,466,449,592	24,441,423	12,319,234	4,478,571,781	109.2
4,383,222,779	4,352,816,494	30,406,285	1,721,851	4,381,500,928	106.9
4,561,138,863	4,495,847,841	65,291,022	1,542,838	4,559,596,025	107.0
4,536,481,104	4,516,226,347	20,254,757	7,140,578	4,529,340,526	106.3
4,494,834,400	4,470,080,858	24,753,542	805,052	4,494,029,348	104.5
4,582,909,637	4,492,881,740	90,027,897	4,189,004	4,578,720,633	104.1
673,508,198	647,111,680	26,396,518	503,840	673,004,358	103.8
73,646,361	72,452,218	1,194,143	89,651	73,556,710	107.6
636,923,092	636,592,067	331,025	33,098	636,889,994	107.9
72,948,073	72,027,656	920,417	113,926	72,834,147	95.6
651,997,639	650,731,566	1,266,073	19,503	651,978,136	104.2
112,480,059	100,822,472	11,657,587	—	112,480,059	98.6
729,981,280	706,277,533	23,703,747	3,001	729,978,279	106.9
125,228,251	112,440,934	12,787,317	13,448	125,214,803	97.9
678,821,886	675,544,976	3,276,910	87,581	678,734,305	103.8
90,366,314	87,527,139	2,839,175	283,765	90,082,549	102.1
629,152,293	627,904,527	1,247,766	2,978,995	626,173,298	105.1
107,856,191	103,448,972	4,407,219	62,196	107,793,995	83.8

表 2 歷年各項稅捐預算數、查定數與實徵數 (續8)

(二)稅課收入

8. 娛樂稅

單位：新臺幣元

年度(月)別 Fiscal Year (Month)	預算數 Budget Amount (A)	查定數 Audited Amount		
		合計 Total	本年度 Current FY	以前年度 Previous FY
97 年度 FY 2008	242,000,000	268,489,788	224,280,384	44,209,404
98 年度 FY 2009	220,000,000	242,229,432	212,177,330	30,052,102
99 年度 FY 2010	210,000,000	248,327,528	228,981,000	19,346,528
100 年度 FY 2011	200,000,000	259,975,890	245,430,367	14,545,523
101 年度 FY 2012	200,000,000	239,594,695	227,269,673	12,325,022
102 年度 FY 2013	230,000,000	241,617,104	228,753,147	12,863,957
103 年度 FY 2014	215,000,000	247,274,144	236,576,455	10,697,689
104 年度 FY 2015	215,000,000	289,194,798	278,172,233	11,022,565
105 年度 FY 2016	215,000,000	251,001,805	239,938,199	11,063,606
106 年度 FY 2017	230,000,000	270,417,166	257,361,771	13,055,395
1 月 Jan.	14,553,000	38,057,411	25,020,578	13,036,833
2 月 Feb.	18,052,000	19,988,302	19,979,394	8,908
3 月 Mar.	23,070,000	25,645,617	25,628,432	17,185
4 月 Apr.	15,590,000	17,972,448	17,980,783	- 8,335
5 月 May	20,862,000	19,475,889	19,476,017	- 128
6 月 June	19,664,000	17,285,758	17,285,890	- 132
7 月 July	17,367,000	21,046,898	21,046,508	390
8 月 Aug.	19,974,000	26,041,335	26,039,432	1,903
9 月 Sep.	21,756,000	19,924,266	19,929,865	- 5,599
10 月 Oct.	15,502,000	25,981,368	25,976,998	4,370
11 月 Nov.	19,051,000	20,058,189	20,058,189	—
12 月 Dec.	24,559,000	18,939,685	18,939,685	—

Table 2. Budget Amount, Audited Amount and Actual Collection
in Recent Years (Cont. 8)

(II) Revenues from Taxes

8. Amusement Tax

Unit : N.T.\$1

實徵數 Actual Collection			退還以前年度 歲入款 Tax Income Returned (4)	實徵淨額 Net Actual Collection (1-4=5)	實徵淨額 占預算數 % Net Actual Collection /Budget Amount (5/A)×100
合計 Total (2+3=1)	本年度 Current FY (2)	以前年度 Previous FY (3)			
221,995,693	218,593,813	3,401,880	9,506,701	212,488,992	87.8
210,098,246	207,121,900	2,976,346	75,284	210,022,962	95.5
226,941,170	224,986,040	1,955,130	68,614	226,872,556	108.0
244,111,111	242,285,021	1,826,090	303,664	243,807,447	121.9
224,615,319	222,583,805	2,031,514	477,451	224,137,868	112.1
228,951,423	225,358,394	3,593,029	24,053	228,927,370	99.5
235,077,518	232,633,550	2,443,968	202,710	234,874,808	109.2
278,102,890	275,790,845	2,312,045	24,607	278,078,283	129.3
237,963,515	237,032,164	931,351	20,582	237,942,933	110.7
256,668,370	255,409,001	1,259,369	487,028	256,181,342	111.4
18,273,280	17,565,813	707,467	482,517	17,790,763	122.2
27,046,706	26,925,750	120,956	—	27,046,706	149.8
25,359,964	25,285,080	74,884	59	25,359,905	109.9
17,396,125	17,339,243	56,882	110	17,396,015	111.6
19,440,556	19,363,098	77,458	—	19,440,556	93.2
17,204,714	17,148,353	56,361	—	17,204,714	87.5
20,746,549	20,688,288	58,261	1,952	20,744,597	119.4
25,712,134	25,673,851	38,283	—	25,712,134	128.7
18,466,578	18,463,340	3,238	—	18,466,578	84.9
23,987,253	23,972,449	14,804	—	23,987,253	154.7
23,334,153	23,325,649	8,504	—	23,334,153	122.5
19,700,358	19,658,087	42,271	2,390	19,697,968	80.2

表 2 歷年各項稅捐預算數、查定數與實徵數 (續9)

(二)稅課收入

9. 九年國民義務教育附徵教育捐

單位：新臺幣元

(1)小計

年度(月)別 Fiscal Year (Month)	預算數 Budget Amount (A)	查定數 Audited Amount		
		合計 Total	本年度 Current FY	以前年度 Previous FY
97 年度 FY 2008	—	12,539,866	—	12,539,866
98 年度 FY 2009	—	8,274,576	—	8,274,576
99 年度 FY 2010	—	4,999,750	—	4,999,750
100 年度 FY 2011	—	2,226,710	—	2,226,710
101 年度 FY 2012	—	1,200,781	—	1,200,781
102 年度 FY 2013	—	745,571	—	745,571
103 年度 FY 2014	—	424,665	—	424,665
104 年度 FY 2015	—	342,998	—	342,998
105 年度 FY 2016	—	345,398	—	345,398
106 年度 FY 2017	—	57,776	—	57,776
1 月 Jan.	—	341,960	—	341,960
2 月 Feb.	—	—	—	—
3 月 Mar.	—	—	—	—
4 月 Apr.	—	—	—	—
5 月 May	—	—	—	—
6 月 June	—	—	—	—
7 月 July	—	-2,400	—	-2,400
8 月 Aug.	—	—	—	—
9 月 Sep.	—	-212,113	—	-212,113
10 月 Oct.	—	—	—	—
11 月 Nov.	—	-69,671	—	-69,671
12 月 Dec.	—	—	—	—

表 2 歷年各項稅捐預算數、查定數與實徵數 (續10)

(二)稅課收入

9. 九年國民義務教育附徵教育捐

單位：新臺幣元

(2)房屋稅

年度(月)別 Fiscal Year (Month)	預算數 Budget Amount (A)	查定數 Audited Amount		
		合計 Total	本年度 Current FY	以前年度 Previous FY
97 年度 FY 2008	—	10,259,504	—	10,259,504
98 年度 FY 2009	—	7,692,721	—	7,692,721
99 年度 FY 2010	—	4,894,676	—	4,894,676
100 年度 FY 2011	—	2,213,603	—	2,213,603
101 年度 FY 2012	—	1,200,781	—	1,200,781
102 年度 FY 2013	—	745,571	—	745,571
103 年度 FY 2014	—	424,665	—	424,665
104 年度 FY 2015	—	342,998	—	342,998
105 年度 FY 2016	—	345,398	—	345,398
106 年度 FY 2017	—	57,776	—	57,776
1 月 Jan.	—	341,960	—	341,960
2 月 Feb.	—	—	—	—
3 月 Mar.	—	—	—	—
4 月 Apr.	—	—	—	—
5 月 May	—	—	—	—
6 月 June	—	—	—	—
7 月 July	—	-2,400	—	-2,400
8 月 Aug.	—	—	—	—
9 月 Sep.	—	-212,113	—	-212,113
10 月 Oct.	—	—	—	—
11 月 Nov.	—	-69,671	—	-69,671
12 月 Dec.	—	—	—	—

表 2 歷年各項稅捐預算數、查定數與實徵數 (續11)

(二)稅課收入

9. 九年國民義務教育附徵教育捐

單位：新臺幣元

(3)娛樂稅

年度(月)別 Fiscal Year (Month)	預算數 Budget Amount (A)	查定數 Audited Amount		
		合計 Total	本年度 Current FY	以前年度 Previous FY
97 年度 FY 2008	—	2,280,362	—	2,280,362
98 年度 FY 2009	—	581,855	—	581,855
99 年度 FY 2010	—	105,074	—	105,074
100 年度 FY 2011	—	13,107	—	13,107
101 年度 FY 2012	—	—	—	—
102 年度 FY 2013	—	—	—	—
103 年度 FY 2014	—	—	—	—
104 年度 FY 2015	—	—	—	—
105 年度 FY 2016	—	—	—	—
106 年度 FY 2017	—	—	—	—
1 月 Jan.	—	—	—	—
2 月 Feb.	—	—	—	—
3 月 Mar.	—	—	—	—
4 月 Apr.	—	—	—	—
5 月 May	—	—	—	—
6 月 June	—	—	—	—
7 月 July	—	—	—	—
8 月 Aug.	—	—	—	—
9 月 Sep.	—	—	—	—
10 月 Oct.	—	—	—	—
11 月 Nov.	—	—	—	—
12 月 Dec.	—	—	—	—

表 2 歷年各項稅捐預算數、查定數與實徵數 (續12)

(三)工程受益費

單位：新臺幣元

年度(月)別 Fiscal Year (Month)	預算數 Budget Amount (A)	查定數 Audited Amount		
		合計 Total	本年度 Current FY	以前年度 Previous FY
97 年度 FY 2008	—	—	—	—
98 年度 FY 2009	—	—	—	—
99 年度 FY 2010	—	—	—	—
100 年度 FY 2011	—	42,197	—	42,197
101 年度 FY 2012	—	—	—	—
102 年度 FY 2013	—	—	—	—
103 年度 FY 2014	—	—	—	—
104 年度 FY 2015	—	—	—	—
105 年度 FY 2016	—	—	—	—
106 年度 FY 2017	—	—	—	—
1 月 Jan.	—	—	—	—
2 月 Feb.	—	—	—	—
3 月 Mar.	—	—	—	—
4 月 Apr.	—	—	—	—
5 月 May	—	—	—	—
6 月 June	—	—	—	—
7 月 July	—	—	—	—
8 月 Aug.	—	—	—	—
9 月 Sep.	—	—	—	—
10 月 Oct.	—	—	—	—
11 月 Nov.	—	—	—	—
12 月 Dec.	—	—	—	—

表 2 歷年各項稅捐預算數、查定數與實徵數 (續13)

(四)罰鍰收入

單位：新臺幣元

年度(月)別 Fiscal Year (Month)	預算數 Budget Amount (A)	查定數 Audited Amount		
		合計 Total	本年度 Current FY	以前年度 Previous FY
97年度 FY 2008	204,000,000	475,339,022	162,206,174	313,132,848
98年度 FY 2009	201,000,000	494,714,768	157,439,459	337,275,309
99年度 FY 2010	155,000,000	547,722,155	204,193,586	343,528,569
100年度 FY 2011	154,000,000	563,414,313	133,481,505	429,932,808
101年度 FY 2012	135,000,000	496,099,434	98,656,201	397,443,233
102年度 FY 2013	131,000,000	493,644,600	101,500,747	392,143,853
103年度 FY 2014	104,000,000	428,292,564	74,173,335	354,119,229
104年度 FY 2015	114,000,000	356,237,931	61,313,858	294,924,073
105年度 FY 2016	105,000,000	358,998,037	73,060,845	285,937,192
106年度 FY 2017	98,000,000	389,999,844	82,298,247	307,701,597
1月 Jan.	9,361,000	273,511,773	2,919,023	270,592,750
2月 Feb.	5,659,000	10,598,543	1,877,476	8,721,067
3月 Mar.	8,732,000	6,932,153	3,335,415	3,596,738
4月 Apr.	4,760,000	8,459,880	6,626,154	1,833,726
5月 May	9,578,000	13,578,917	6,668,927	6,909,990
6月 June	9,977,000	12,676,544	9,110,430	3,566,114
7月 July	8,113,000	17,314,839	13,701,017	3,613,822
8月 Aug.	8,126,000	6,668,942	4,463,313	2,205,629
9月 Sep.	4,702,000	4,474,754	3,309,599	1,165,155
10月 Oct.	6,935,000	7,945,921	6,499,560	1,446,361
11月 Nov.	8,811,000	10,627,940	9,440,068	1,187,872
12月 Dec.	13,246,000	17,209,638	14,347,265	2,862,373

Table 2. Budget Amount, Audited Amount and Actual Collection
in Recent Years (Cont. 13)

(IV) Punitive Fine Revenue

Unit : N.T.\$1

實徵數 Actual Collection			退還以前年度 歲入款 Tax Income Returned (4)	實徵淨額 Net Actual Collection (1-4=5)	實徵淨額 占預算數 % Net Actual Collection /Budge Amount (5/A)×100
合計 Total (2+3=1)	本年度 Current FY (2)	以前年度 Previous FY (3)			
191,887,419	64,189,183	127,698,236	8,921,665	182,965,754	89.7
199,652,733	58,490,467	141,162,266	47,262,251	152,390,482	75.8
165,963,949	62,178,322	103,785,627	105,644,011	60,319,938	38.9
188,127,746	59,663,707	128,464,039	27,995,613	160,132,133	104.0
130,740,906	43,159,508	87,581,398	12,973,313	117,767,593	87.2
143,182,097	55,284,547	87,897,550	13,370,440	129,811,657	99.1
105,643,689	41,076,486	64,567,203	3,757,801	101,885,888	98.0
101,262,895	42,028,868	59,234,027	6,209,105	95,053,790	83.4
92,477,328	43,892,444	48,584,884	4,628,089	87,849,239	83.7
110,585,410	53,531,282	57,054,128	7,192,558	103,392,852	105.5
7,137,935	1,568,337	5,569,598	600,255	6,537,680	69.8
11,057,264	1,221,249	9,836,015	247,185	10,810,079	191.0
5,982,162	990,647	4,991,515	844,610	5,137,552	58.8
4,590,326	1,784,117	2,806,209	610,727	3,979,599	83.6
12,868,941	4,620,768	8,248,173	1,427,669	11,441,272	119.5
12,333,039	6,958,474	5,374,565	198,966	12,134,073	121.6
11,352,943	6,071,420	5,281,523	234,541	11,118,402	137.0
6,804,008	2,899,884	3,904,124	907,032	5,896,976	72.6
5,857,997	3,256,318	2,601,679	369,991	5,488,006	116.7
5,954,085	3,634,560	2,319,525	811,321	5,142,764	74.2
6,833,038	4,616,428	2,216,610	568,699	6,264,339	71.1
19,813,672	15,909,080	3,904,592	371,562	19,442,110	146.8

表 2 歷年各項稅捐預算數、查定數與實徵數 (續14完)

(五)規費收入

單位：新臺幣元

監證費

年度(月)別 Fiscal Year (Month)	預算數 Budget Amount (A)	查定數 Audited Amount		
		合計 Total	本年度 Current FY	以前年度 Previous FY
97 年度 FY 2008	—	—	—	—
98 年度 FY 2009	—	149,080	—	149,080
99 年度 FY 2010	—	—	—	—
100 年度 FY 2011	—	—	—	—
101 年度 FY 2012	—	—	—	—
102 年度 FY 2013	—	—	—	—
103 年度 FY 2014	—	—	—	—
104 年度 FY 2015	—	—	—	—
105 年度 FY 2016	—	—	—	—
106 年度 FY 2017	—	—	—	—
1 月 Jan.	—	—	—	—
2 月 Feb.	—	—	—	—
3 月 Mar.	—	—	—	—
4 月 Apr.	—	—	—	—
5 月 May	—	—	—	—
6 月 June	—	—	—	—
7 月 July	—	—	—	—
8 月 Aug.	—	—	—	—
9 月 Sep.	—	—	—	—
10 月 Oct.	—	—	—	—
11 月 Nov.	—	—	—	—
12 月 Dec.	—	—	—	—

Table 2. Budget Amount, Audited Amount and Actual Collection
in Recent Years (Cont. 14 End)

(V) Fees Revenue

實徵數 Actual Collection			Fees		
合計 Total (2+3=1)	Actual Collection		退還以前年度 歲入款 Tax Income Returned (4)	實徵淨額 Net Actual Collection (1-4=5)	實徵淨額 占預算數 % Net Actual Collection /Budge Amount (5/A)×100
	本年度 Current FY (2)	以前年度 Previous FY (3)			
—	—	—	—	—	--
149,080	—	149,080	—	149,080	--
—	—	—	—	—	--
—	—	—	—	—	--
—	—	—	—	—	--
—	—	—	—	—	--
—	—	—	—	—	--
—	—	—	—	—	--
—	—	—	—	—	--
—	—	—	—	—	--
—	—	—	—	—	--
—	—	—	—	—	--
—	—	—	—	—	--
—	—	—	—	—	--
—	—	—	—	—	--
—	—	—	—	—	--
—	—	—	—	—	--
—	—	—	—	—	--
—	—	—	—	—	--
—	—	—	—	—	--
—	—	—	—	—	--
—	—	—	—	—	--
—	—	—	—	—	--

Unit : N.T.\$1

表 3 各項稅捐納庫數

(一)歷年別

單位：新臺幣元

年 度 (月) 別 Fiscal Year (Month)	實 徵 數 ① Actual Collection	納 庫 數	
		合 計 Total	國 庫 Nation Treasury
97 年 度 FY 2008 ③	57,349,343,608	57,349,343,608	—
98 年 度 FY 2009	57,906,303,509	57,906,010,169	—
99 年 度 FY 2010 ④	61,412,898,686	61,412,898,686	—
100 年 度 FY 2011	62,364,742,945	62,364,742,945	—
101 年 度 FY 2012 ⑤	62,751,393,789	62,751,393,789	—
102 年 度 FY 2013 ⑥	66,673,882,137	66,673,882,137	—
103 年 度 FY 2014	67,721,827,234	67,721,827,234	—
104 年 度 FY 2015 ⑦	77,243,428,036	77,243,428,036	—
105 年 度 FY 2016 ⑧	75,770,755,206	75,770,755,206	—
106 年 度 FY 2017 ⑨	75,368,503,602	75,368,503,602	—
1 月 Jan.	2,977,961,821	2,745,739,827	—
2 月 Feb.	1,604,196,768	1,578,613,383	—
3 月 Mar.	3,028,565,136	2,519,778,989	—
4 月 Apr.	5,073,082,965	4,619,440,355	—
5 月 May	13,594,166,685	11,815,268,563	—
6 月 June	8,046,170,303	10,678,723,929	—
7 月 July	2,198,915,750	2,357,646,683	—
8 月 Aug.	1,793,445,376	1,691,589,680	—
9 月 Sep.	2,269,580,894	2,279,712,572	—
10 月 Oct.	1,936,335,359	1,690,498,494	—
11 月 Nov.	18,104,020,128	13,984,016,312	—
12 月 Dec.	14,742,062,417	19,407,474,815	—

資料來源：依據徵課會計報告編製。

附 註：①自99年度起實徵數未含實物抵繳稅款(以遞延收入入帳)。

②年度之未納庫數係歷年實物抵繳稅款累計數。

③以前年度實物抵繳469元於97年度變賣納庫。

④以前年度實物抵繳34,323元於99年度變賣納庫。

Table 3. Taxation Forwarded to Treasury

(I) Fiscal Year

Unit : N.T.\$1

Pay to Treasury			未納庫數 Unpay to ② Treasury
中央統籌專戶 Distribution of Central Gov't	重建基金庫 Reconstruction Fund	市庫 The Municipal Treasury	
—	—	57,349,343,608	58,886,859
—	—	57,906,010,169	59,180,199
—	—	61,412,898,686	59,145,876
—	—	62,364,742,945	59,145,876
—	—	62,751,393,789	59,489,460
—	—	66,673,882,137	59,451,157
—	—	67,721,827,234	59,451,157
—	—	77,243,428,036	59,396,611
—	—	75,770,755,206	60,060,477
—	—	75,368,503,602	60,040,250
—	—	2,745,739,827	232,221,994
—	—	1,578,613,383	257,805,379
—	—	2,519,778,989	766,591,526
—	—	4,619,440,355	1,220,234,136
—	—	11,815,268,563	2,999,132,258
—	—	10,678,723,929	366,578,632
—	—	2,357,646,683	207,847,699
—	—	1,691,589,680	309,703,395
—	—	2,279,712,572	299,571,717
—	—	1,690,498,494	545,408,582
—	—	13,984,016,312	4,665,412,398
—	—	19,407,474,815	—

⑤101年度未納庫數含實物抵繳343,584元。

⑥以前年度實物抵繳38,303元於102年度變賣納庫。

⑦以前年度實物抵繳54,546元於104年度變賣納庫。

⑧105年度未納庫數含實物抵繳663,866元。

⑨以前年度實物抵繳20,227元於106年度註銷。

表 3 各項稅捐納庫數(續)

(二)稅目別
106年度

單位：新臺幣元

稅目別 Item of Tax	實徵數 Actual Collection	納庫數 Pay to Treasury			
		合計 Total	國庫 The Nation Treasury	中央統籌專戶 Distribution of Central Gov't	重建基金庫 Reconstruction Fund
總計 Grand Total	75,368,503,602	75,368,503,602	—	—	—
地價稅 Land Value Tax	29,837,828,096	29,837,828,096	—	—	—
土地增值稅 Land value Increment Tax	15,868,966,932	15,868,966,932	—	—	—
房屋稅 House Tax	15,687,184,947	15,687,184,947	—	—	—
使用牌照稅 Vehicle License Tax	7,509,640,047	7,509,640,047	—	—	—
契稅 Deed Tax	1,514,720,163	1,514,720,163	—	—	—
印花稅 Stamp Tax	4,582,909,637	4,582,909,637	—	—	—
娛樂稅 Amusement Tax	256,668,370	256,668,370	—	—	—
教育捐 Education Surtax	—	—	—	—	—
工程受益費 Construction Benefit Fee	—	—	—	—	—
罰鍰收入 Punitive Fine Revenue	110,585,410	110,585,410	—	—	—
規費收入 Fees Revenue	—	—	—	—	—

Table 3. Taxation Forwarded to Treasury (Cont.)

(II) Item of Tax				
FY 2017				
Unit : N.T.\$1				
退還以前年度歲入款 Tax Income Returned				
市 庫 The Municipal Treasury	合 計 Total	國 庫 The Nation Treasury	中央統籌專戶 Distribution of Central Gov't	市 庫 The Municipal Treasury
75,368,503,602	376,250,693	—	—	376,250,693
29,837,828,096	41,814,851	—	—	41,814,851
15,868,966,932	252,906,867	—	—	252,906,867
15,687,184,947	61,577,451	—	—	61,577,451
7,509,640,047	3,868,134	—	—	3,868,134
1,514,720,163	4,214,800	—	—	4,214,800
4,582,909,637	4,189,004	—	—	4,189,004
256,668,370	487,028	—	—	487,028
—	—	—	—	—
—	—	—	—	—
110,585,410	7,192,558	—	—	7,192,558
—	—	—	—	—

表 4 歷年各項稅捐實徵淨額及指數

基 比：105年度=100

環 比：上年度=100

分 配 比：各年度總計=100

單位：新臺幣千元

稅 目 別 Item of Tax	97年度 FY2008	98年度 FY2009			99年度	
	實徵淨額 Net Actual Collection	實徵淨額 Net Actual Collection	指數 Index		分配比 Shares	實徵淨額 Net Actual Collection
			基 比 Fixed Index	環 比 Link Index		
總 計 Grand Total	56,753,478	57,498,023	76.2	101.3	100.0	60,905,235
稅 課 收 入 Revenues from Taxes	56,570,534	57,345,484	76.1	101.4	99.7	60,844,915
地 價 稅 Land Value Tax	19,188,394	18,702,394	63.4	97.5	32.5	20,291,042
土地增值稅 Land Value Increment Tax	13,549,409	15,413,916	91.9	113.8	26.8	16,884,890
房 屋 稅 House Tax	10,140,620	10,295,486	67.4	101.5	17.9	10,500,537
使用牌照稅 Vehicle License Tax	6,536,438	6,462,009	86.4	98.9	11.2	6,542,070
契 稅 Deed Tax	2,369,087	2,357,002	149.9	99.5	4.1	2,327,147
印 花 稅 Stamp Tax	4,573,341	3,905,531	86.9	85.4	6.8	4,082,316
娛 樂 稅 Amusement Tax	212,489	210,023	88.3	98.8	0.4	226,873
教 育 捐 Education Surtax	756	-877	--	--	- 0.0	-9,960
工 程 受 益 費 Construction Benefit Fee	-22	--	--	--	--	--
罰 鍰 收 入 Punitive Fine Revenue	182,966	152,390	173.5	83.3	0.3	60,320
規 費 收 入 Fees Revenue	--	149	--	--	0.0	--
契稅監證費 Fees	--	149	--	--	0.0	--

資料來源：依據徵課會計報告編製。

表 5 本處各項稅捐稽徵成本①②

Table 5. Cost of Tax Levying ①②

年度及稅目別 Fiscal Year & Item of Tax	實徵淨額 (千元) Net Actual Collection (N.T.\$1000) (1)	實支經費 (元) Expense (N.T.\$1) (2)	每千元成本 (元) Cost of \$1,000 (2)/(1)
97 年度 FY 2008	56,570,534	894,798,178	15.8174
98 年度 FY 2009	57,345,484	894,489,263	15.5983
99 年度 FY 2010	60,844,915	899,839,885	14.7891
100 年度 FY 2011	61,999,268	888,513,303	14.3310
101 年度 FY 2012	62,189,138	893,122,419	14.3614
102 年度 FY 2013	66,310,719	904,340,532	13.6379
103 年度 FY 2014	67,291,124	915,806,028	13.6096
104 年度 FY 2015	76,823,364	915,744,460	11.9201
105 年度 FY 2016	75,321,811	909,238,030	12.0714
106 年度 FY 2017	74,888,860	909,823,616	12.1490
地價稅 Land Value Tax	29,796,013	261,032,579	8.7607
土地增值稅 Land Value Increment Tax	15,616,060	198,428,311	12.7067
房屋稅 House Tax	15,625,607	240,255,221	15.3757
使用牌照稅 Vehicle License Tax	7,505,772	100,076,099	13.3332
契稅 Deed Tax	1,510,505	44,548,834	29.4927
印花稅 Stamp Tax	4,578,721	37,290,368	8.1443
娛樂稅 Amusement Tax	256,181	28,192,204	110.0478

資料來源：根據本處會計室資料編製。

附註：①依據財政部賦稅署擬訂之各稅稽徵成本計算方式一致性規定說明書之編算原則核計。

②房屋稅與娛樂稅實徵淨額含九年國民義務教育附徵教育捐。

參、稅源及其他

III . Tax Sources and Others

表 6 地價稅稅源

單位 { 面積：公頃
金額：新臺幣千元

年別及稅地種類別		戶數	筆數
Year & Classification		No. of House	Plots
102	年 2013	867,911	1,917,506
103	年 2014	875,372	1,941,736
104	年 2015	881,734	1,960,793
105	年 2016	889,256	1,982,838
106	年 2017	894,347	2,002,314
公	有 Public	515	137,370
一般土地	Regular Land	485	123,754
自用住宅用地	Self-use Residence Land	13	167
工礦業等用地	Specific Business Land	—	150
公共設施保留地	Land Reserved for Public Facilities	17	13,299
私	有 Private	893,832	1,864,944
一般土地	Regular Land	382,794	838,318
第一級	Level 1	379,344	798,051
第二級	Level 2	3,005	27,597
第三級	Level 3	215	2,697
第四級	Level 4	82	1,225
第五級	Level 5	41	600
第六級	Level 6	107	8,148
自用住宅用地	Self-use Residence Land	508,213	946,084
都市土地	Urban Land	508,213	946,084
非都市土地	Non-Urban Land	—	—
工礦業等用地	Specific Business Land	24	2,043
公共設施保留地	Land Reserved for Public Facilities	2,801	78,499

資料來源：依據本處財產稅科資料編製。

Table 6. Sources of Land Value Tax

Unit: { Area : Hectare Amount : N.T.\$1,000		
課 稅 面 積 Taxed Area	課 稅 地 價 Taxed Land Value	地 價 稅 額 Land Value Tax
4,951.7003	2,247,409,509	22,164,453
4,971.4676	2,253,998,074	22,260,505
4,952.6736	2,242,518,610	22,048,902
4,957.1873	2,999,585,466	29,681,879
4,976.3728	3,006,897,174	29,221,409
324.9699	239,746,264	2,325,966
300.4587	229,355,865	2,293,559
19.6370	7,630,117	15,260
0.2149	146,301	1,463
4.6593	2,613,981	15,684
4,651.4028	2,767,150,910	26,895,443
2,334.3142	1,379,621,601	23,576,155
1,544.7673	835,405,879	8,354,048
373.7003	208,048,715	2,595,680
76.2639	52,629,760	880,186
46.7674	38,951,307	842,780
30.6207	24,712,647	656,001
262.1946	219,873,293	10,247,461
2,121.5136	1,308,946,681	2,617,864
2,121.5136	1,308,946,681	2,617,864
—	—	—
91.8399	57,482,369	574,824
103.7351	21,100,258	126,600

表 7 土地增值稅稅源

單位 { 面積：公頃
金額：新臺幣千元

年度及稅率別 Fiscal Year & Rate of Tax	筆數 Plots	面積 Area	移轉現值 Present Value of Transfer	調整後原地價 Originally Declared Value After Adjustment
97 年 度 FY2008	134,635	513.1119	418,194,495	299,218,322
98 年 度 FY2009	124,589	415.3626	411,747,421	286,607,620
99 年 度 FY2010	138,294	509.0032	440,310,323	305,753,138
100 年 度 FY2011	127,170	436.1678	382,853,776	252,580,246
101 年 度 FY2012	102,169	334.1813	321,992,197	193,999,469
102 年 度 FY2013	105,050	324.0251	353,553,228	200,038,953
103 年 度 FY2014	96,178	301.5794	325,747,728	167,132,088
104 年 度 FY2015	88,557	286.3694	387,856,294	203,230,575
105 年 度 FY2016	65,045	236.5065	279,654,799	133,872,812
106 年 度 FY2017	71,049	198.6735	281,709,632	151,960,124
自用住宅用地 Self-use Residence Land	9,419	18.8750	51,574,697	20,964,802
一般用地 Regular Land	35,706	55.0384	132,591,335	74,369,580
稅率20% Rate 20%	25,556	36.4644	88,724,869	62,463,418
稅率30% Rate 30%	4,988	6.6396	20,251,053	8,896,876
稅率40% Rate 40%	5,153	11.9344	23,615,413	3,009,286
其他 Others	9	—	—	—
免稅地 Exempt Land	25,924	124.7601	97,543,601	56,625,742
公有土地 Public Land	791	1.1536	6,439,735	1,080,165
私有土地 Private Land	25,133	123.6064	91,103,865	55,545,577

資料來源：依據本處財產稅科資料編製。

附註：①102年度起含免稅地相關資料。

Table 7. Sources of Land Value Increment Tax

 Unit: { Area : Hectare
 Amount : N.T.\$1,000

改良土地費用 Land Improvement Cost	漲價總數額 Cross Amount of Land Value Increment	查定稅額① Assessment Tax	增繳地價稅① Supplemental Payment of Land Value Tax	減徵稅額① Reduction	應納稅額 Tax Payable
1,266,847	117,709,326	16,157,946	611,854	428,479	15,117,613
2,003,969	123,135,832	17,240,793	684,454	709,141	15,847,198
1,429,814	133,127,371	19,232,065	773,734	861,337	17,596,994
659,623	129,613,907	18,695,238	727,894	646,878	17,320,466
261,858	127,730,870	17,406,309	705,764	550,475	16,150,070
335,014	157,067,733	38,289,539	817,989	441,657	20,368,311
1,607,913	159,997,437	38,641,701	949,642	1,379,617	20,962,675
345,072	186,858,703	43,430,844	1,086,187	5,124,784	25,848,413
146,513	147,350,302	34,705,263	899,960	4,026,857	19,311,984
1,461,131	131,041,097	29,631,748	797,583	3,304,118	16,097,535
8,192	30,601,702	3,060,166	142,133	34,434	2,881,902
186,662	58,035,092	14,039,429	557,433	1,210,044	13,215,633
7,375	26,254,077	5,252,120	170,154	3,048	5,071,579
4,705	11,349,471	2,507,889	97,761	28,793	2,371,309
174,582	20,431,544	6,279,211	289,519	1,178,203	5,772,536
—	—	208	—	—	208
1,266,277	42,404,302	12,532,153	98,016	2,059,640	—
—	5,371,389	1,639,110	9,700	314,953	—
1,266,277	37,032,913	10,893,043	88,316	1,744,688	—

表 8 房 屋 稅 稅 源

單位 { 面積：平方公尺
金額：新臺幣千元

年度別、構造及使用別 Fiscal Year & Structure & Use				合計 Total		
				戶數 Number of House	面積 Area	現值 Value
102	年	度	FY2013	1,105,979	184,555,387	846,250,956
103	年	度	FY2014	1,112,554	187,129,628	860,003,225
104	年	度	FY2015	1,144,671	194,102,485	967,614,468
105	年	度	FY2016	1,151,272	196,212,276	1,008,671,546
106	年	度	FY2017	1,160,099	217,697,937	1,052,151,144
住	家	用	Residence	775,848	83,695,138	396,299,176
營	業	用	Business	154,095	34,805,926	278,778,487
非住家	非營業	用	Non-Residence、Non-Business	50,430	16,926,788	113,030,271
全部免稅及部份免稅 Exempt House				179,726	82,270,085	264,043,209
鋼骨混凝土造 Steeled Concrete				37,972	26,699,986	372,798,658
住	家	用	Residence	18,826	3,618,312	95,418,055
營	業	用	Business	10,095	8,738,939	138,137,090
非住家	非營業	用	Non-Residence、Non-Business	5,722	4,857,370	52,706,545
全部免稅及部份免稅 Exempt House				3,329	9,485,365	86,536,967
鋼筋混凝土及預鑄造 Concrete&Reinforced Prefabricated				967,523	173,582,429	658,921,647
住	家	用	Residence	707,143	73,093,349	291,983,735
營	業	用	Business	119,823	22,994,322	136,446,012
非住家	非營業	用	Non-Residence、Non-Business	42,155	11,607,429	59,704,163
全部免稅及部份免稅 Exempt House				98,402	65,887,329	170,787,736
鋼筋混凝土加強磚造 Ferroconcrete Brick				107,409	12,726,607	15,748,494
住	家	用	Residence	42,313	5,890,991	7,544,643
營	業	用	Business	16,706	2,076,932	3,000,742
非住家	非營業	用	Non-Residence、Non-Business	1,658	294,423	410,641
全部免稅及部份免稅 Exempt House				46,732	4,464,261	4,792,468
鋼 鐵 造 Metal				7,671	1,515,272	2,031,848
住	家	用	Residence	2,747	421,222	576,859
營	業	用	Business	2,077	575,602	780,867
非住家	非營業	用	Non-Residence、Non-Business	383	95,832	129,142
全部免稅及部份免稅 Exempt House				2,464	422,616	544,980

資料來源：依據本處財產稅科資料編製。

Table 8. Sources of House Tax

 Unit: $\begin{cases} \text{Area : m}^2 \\ \text{Amount : N.T. \$1,000} \end{cases}$

公有 Public			私有 Private		
戶數 Number of House	面積 Area	現值 Value	戶數 Number of House	面積 Area	現值 Value
25,082	24,155,256	102,135,487	1,080,897	160,400,131	744,115,469
22,095	24,565,303	103,075,967	1,090,459	162,564,325	756,927,258
23,165	25,083,249	104,999,438	1,121,506	169,019,236	862,615,030
23,043	25,770,665	113,535,160	1,128,229	170,441,611	895,136,387
22,958	25,931,035	114,339,119	1,137,141	191,766,902	937,812,025
3,562	386,719	1,827,301	772,286	83,308,419	394,471,876
1,297	1,376,568	9,111,371	152,798	33,429,357	269,667,117
488	1,870,745	6,039,893	49,942	15,056,043	106,990,379
17,611	22,297,003	97,360,555	162,115	59,973,082	166,682,654
673	4,628,633	38,121,026	37,299	22,071,353	334,677,632
23	5,225	36,571	18,803	3,613,087	95,381,483
167	363,387	3,294,326	9,928	8,375,552	134,842,765
65	356,139	1,559,212	5,657	4,501,231	51,147,333
418	3,903,882	33,230,916	2,911	5,581,484	53,306,051
15,211	19,926,035	74,535,509	952,312	153,656,395	584,386,138
3,481	372,364	1,777,515	703,662	72,720,985	290,206,220
911	960,514	5,735,304	118,912	22,033,808	130,710,708
388	1,505,043	4,467,448	41,767	10,102,386	55,236,715
10,431	17,088,113	62,555,241	87,971	48,799,215	108,232,494
2,179	700,573	989,430	105,230	12,026,033	14,759,064
33	6,544	9,179	42,280	5,884,447	7,535,464
98	31,542	52,874	16,608	2,045,390	2,947,868
20	4,652	5,107	1,638	289,771	405,534
2,028	657,835	922,271	44,704	3,806,425	3,870,197
220	134,607	251,374	7,451	1,380,665	1,780,474
1	213	281	2,746	421,009	576,578
20	5,126	10,865	2,057	570,476	770,003
5	1,803	3,828	378	94,029	125,314
194	127,465	236,401	2,270	295,151	308,580

表 8 房 屋 稅 稅 源 (續)

單位 { 面積：平方公尺
金額：新臺幣千元

年度別、構造及使用別 Fiscal Year & Structure & Use	合 計 Total		
	戶 數 Number of House	面 積 Area	現 值 Value
磚 石 造 Brick	28,672	2,481,230	2,260,883
住 家 用 Residence	4,551	627,093	732,140
營 業 用 Business	4,091	337,002	351,123
非 住 家 非 營 業 用 Non-Residence、Non-Business	418	62,651	73,678
全部免稅及部份免稅 Exempt House	19,612	1,454,484	1,103,942
啫 咕 石 造 Lo-Ko Stone	441	25,770	15,721
住 家 用 Residence	18	1,986	1,797
營 業 用 Business	80	3,510	2,778
非 住 家 非 營 業 用 Non-Residence、Non-Business	8	1,015	660
全部免稅及部份免稅 Exempt House	335	19,259	10,485
卵 石 混 凝 土 造 Concrete & Pebble	47	4,894	4,055
住 家 用 Residence	10	1,840	1,860
營 業 用 Business	1	227	126
非 住 家 非 營 業 用 Non-Residence、Non-Business	1	139	145
全部免稅及部份免稅 Exempt House	35	2,689	1,925
木 造 Wood	8,799	562,713	363,753
住 家 用 Residence	232	38,965	39,022
營 業 用 Business	1,206	76,192	59,276
非 住 家 非 營 業 用 Non-Residence、Non-Business	85	7,930	5,297
全部免稅及部份免稅 Exempt House	7,276	439,626	260,159
土 磚 造 Earthen Brick	1,372	91,052	5,460
住 家 用 Residence	8	1,380	1,065
營 業 用 Business	9	1,251	200
非 住 家 非 營 業 用 Non-Residence、Non-Business	—	—	—
全部免稅及部份免稅 Exempt House	1,355	88,422	4,194
竹 造 Bamboo	193	7,984	626
住 家 用 Residence	—	—	—
營 業 用 Business	7	1,949	272
非 住 家 非 營 業 用 Non-Residence、Non-Business	—	—	—
全部免稅及部份免稅 Exempt House	186	6,035	354

Table 8. Sources of House Tax (Cont.)

 Unit: $\begin{cases} \text{Area : m}^2 \\ \text{Amount : N.T. \$1,000} \end{cases}$

公有 Public			私有 Private		
戶數 Number of House	面積 Area	現值 Value	戶數 Number of House	面積 Area	現值 Value
2,325	348,042	321,255	26,347	2,133,188	1,939,629
23	2,247	3,585	4,528	624,846	728,555
56	11,644	14,565	4,035	325,359	336,558
8	2,865	4,185	410	59,786	69,493
2,238	331,286	298,920	17,374	1,123,197	805,022
21	1,250	723	420	24,520	14,997
—	—	—	18	1,986	1,797
—	—	—	80	3,510	2,778
—	—	—	8	1,015	660
21	1,250	723	314	18,009	9,762
1	136	58	46	4,758	3,998
—	—	—	10	1,840	1,860
—	—	—	1	227	126
—	—	—	1	139	145
1	136	58	34	2,553	1,867
2,308	190,910	119,716	6,491	371,803	244,037
1	125	169	231	38,840	38,852
45	4,355	3,438	1,161	71,836	55,838
2	244	113	83	7,686	5,184
2,260	186,185	115,996	5,016	253,441	144,162
14	595	19	1,358	90,457	5,441
—	—	—	8	1,380	1,065
—	—	—	9	1,251	200
—	—	—	—	—	—
14	595	19	1,341	87,827	4,175
6	255	10	187	7,729	616
—	—	—	—	—	—
—	—	—	7	1,949	272
—	—	—	—	—	—
6	255	10	180	5,780	344

表 9 使用牌照稅稅源 ① ②

單位：件數

年 度 (月) 別 Fiscal Year (Month)			合 計 Grand Total		小客車③ Sedan	
			應 稅 Taxable	免 稅 Exempt	應 稅 Taxable	免 稅 Exempt
97	年 度	FY2008	746,054	16,177	644,206	15,696
98	年 度	FY2009	740,831	17,330	638,594	16,937
99	年 度	FY2010	760,699	17,301	654,886	16,779
100	年 度	FY2011	785,192	14,007	675,588	13,311
101	年 度	FY2012	807,716	17,117	693,474	16,256
102	年 度	FY2013	830,876	17,321	711,151	16,698
103	年 度	FY2014	879,372	16,690	746,060	15,827
104	年 度	FY2015	917,529	16,843	777,147	16,216
105	年 度	FY2016	933,409	16,994	787,565	16,421
106	年 度	FY2017	944,399	16,610	791,710	16,206
1	月	Jan.	16,358	1,180	13,947	1,162
2	月	Feb.	15,800	948	13,271	930
3	月	Mar.	59,413	1,816	49,323	1,788
4	月	Apr.	325,409	1,632	278,656	1,607
5	月	May	334,891	1,450	286,420	1,414
6	月	June	13,037	1,382	11,117	1,368
7	月	July	18,132	1,414	15,080	1,390
8	月	Aug.	18,756	1,413	15,575	1,377
9	月	Sep.	11,220	1,343	8,658	1,303
10	月	Oct.	24,537	1,242	17,477	1,230
11	月	Nov.	101,867	1,428	78,529	1,331
12	月	Dec.	4,979	1,362	3,657	1,306

資料來源：依據本處機會稅科資料編製。

附 註：①本表臨時牌照、試車牌照及外賓車輛不予計列。

②102年以前件數為本年度實徵件數，103年起件數為本年度實徵件數+以前年度實徵件數。

③小客車、大客車、貨車中均分為自用與營業用，自用全年開徵1次。營業用分兩期開徵，表列數字均依照年度結束累計數填列。

Table 9. Sources of Vehicle License Tax ① ②

Unit : Case

大客車③ Bus		貨車③ Truck		機器腳踏車 Motorcycle	
應 稅 Taxable	免 稅 Exempt	應 稅 Taxable	免 稅 Exempt	應 稅 Taxable	免 稅 Exempt
6,582	257	87,197	220	8,069	4
6,682	213	86,878	168	8,677	12
7,535	318	88,809	171	9,469	33
7,961	520	90,583	154	11,060	22
8,237	643	92,732	197	13,273	21
8,485	423	93,267	164	17,973	36
9,161	528	100,464	311	23,687	24
9,871	155	101,822	437	28,689	35
9,742	178	102,994	365	33,108	30
9,559	158	103,195	217	39,935	29
254	4	1,258	13	899	1
131	—	1,401	18	997	—
386	13	4,899	8	4,805	7
1,913	17	28,918	2	15,922	6
2,320	21	36,132	13	10,019	2
93	10	572	2	1,255	2
151	8	1,461	14	1,440	2
121	30	1,703	5	1,357	1
210	33	1,339	6	1,013	1
1,869	—	4,434	7	757	5
1,803	—	20,795	96	740	1
308	22	283	33	731	1

表 10 契 稅 稅 源

金額單位：新臺幣千元

年 度 別 Fiscal Year		合 計 Total		買 賣 契 Sale		典 權 契 Mortgage	
		件 數 Cases	契 價 Deed Value	件 數 Cases	契 價 Deed Value	件 數 Cases	契 價 Deed Value
97	年 度 FY2008	75,310	41,816,490	67,242	38,369,514	—	—
98	年 度 FY2009	74,931	41,053,558	66,802	38,260,775	1	486
99	年 度 FY2010	75,298	40,464,169	66,392	37,287,407	1	0
100	年 度 FY2011	61,336	35,197,097	51,816	31,575,261	1	133
101	年 度 FY2012	51,933	31,062,867	41,217	27,193,643	—	—
102	年 度 FY2013	51,550	29,279,464	41,398	25,134,588	1	513
103	年 度 FY2014	43,604	29,226,966	32,877	25,239,643	—	—
104	年 度 FY2015	41,172	50,288,879	29,966	36,035,849	—	—
105	年 度 FY2016	31,325	27,820,341	23,458	23,474,523	—	—
106	年 度 FY2017	33,465	28,339,512	25,328	23,640,584	1	34
1月至3月	Cumulative Jan.-Mar.	8,566	7,282,828	5,708	5,897,689	—	—
1月至6月	Cumulative Jan.-June	17,190	15,912,661	12,473	12,858,731	1	34
1月至9月	Cumulative Jan.-Sep.	25,160	22,203,153	18,784	18,019,357	1	34
1月至12月	Cumulative Jan.-Dec.	33,465	28,339,512	25,328	23,640,584	1	34

資料來源：依據本處財產稅科資料編製。

附 註：本表件數含應稅與免稅。

Table 10. Sources of Deed Tax

Unit : N.T.\$1,000

交換契 Exchange		贈與契 Donation		分割契 Division		占有契 Staking	
件數 Cases	契價 Deed Value	件數 Cases	契價 Deed Value	件數 Cases	契價 Deed Value	件數 Cases	契價 Deed Value
1,308	1,306,651	6,590	1,721,469	170	418,856	—	—
1,013	911,399	7,015	1,854,852	100	26,046	—	—
894	815,303	7,914	2,207,685	97	153,774	—	—
1,117	1,120,083	8,350	2,490,558	52	11,062	—	—
1,178	1,079,514	9,474	2,771,281	64	18,429	—	—
864	1,283,123	9,215	2,783,729	72	77,512	—	—
779	1,050,449	9,818	2,815,271	130	121,602	—	—
1,271	10,627,430	9,856	3,313,263	79	312,337	—	—
846	2,121,748	6,937	2,189,943	84	34,126	—	—
814	2,373,479	7,285	2,317,342	36	8,059	1	13
212	691,242	2,631	692,540	15	1,358	—	—
397	1,532,061	4,295	1,518,848	24	2,988	—	—
636	2,050,796	5,712	2,128,294	26	4,660	1	13
814	2,373,479	7,285	2,317,342	36	8,059	1	13

表 11 印花稅稅源 ①

單位：新臺幣千元

年度別 Fiscal Year	合計① Total	出售印 花稅票 Taxes Stamps	總	
			金融業 Finance	保險業 Insurance
97 年 度 FY2008	4,555,750	755,125	1,398,692	896,879
98 年 度 FY2009	3,890,354	568,107	1,093,360	634,146
99 年 度 FY2010	4,061,562	565,080	1,138,041	575,952
100 年 度 FY2011	4,232,189	514,547	1,175,596	616,064
101 年 度 FY2012	4,466,450	477,820	1,182,223	684,628
102 年 度 FY2013	4,381,501	448,112	1,223,112	706,812
103 年 度 FY2014	4,559,596	481,664	1,294,717	747,219
104 年 度 FY2015	4,529,341	462,108	1,336,906	784,326
年度別 Fiscal Year	合計① Total	出售印 花稅票 Taxes Stamps	金融業 Finance	保險業 Insurance
105 年 度 FY2016	4,494,029	457,681	1,350,707	811,200
106 年 度 FY2017	4,458,982	391,169	1,388,677	848,806
1月至3月 Cumulative Jan.-Mar.	1,342,519	88,751	440,283	284,855
1月至6月 Cumulative Jan.-June	2,157,677	179,991	676,301	422,808
1月至9月 Cumulative Jan.-Sep.	3,653,272	317,564	1,150,798	716,640
1月至12月 Cumulative Jan.-Dec.	4,458,982	391,169	1,388,677	848,806

資料來源：依據本處機會稅科資料編製。

附註：①102年至105年為本年度實徵淨額，其餘年度為本年度實徵數。

Table 11. Sources of Stamp Tax ①

Unit : N.T.\$1,000

繳					Total Payment	違章補繳 Payment on Tax Evasion
傳播業 Broadcasting	公用事業 Utilities	承攬契據 Construction agreements	財產契據 Real Estate Deed	其他 Others		
2,451	14,085	451,229	265,633	771,592	65	
2,067	19,497	384,248	279,449	909,358	122	
2,035	22,504	391,806	330,777	1,035,364	3	
1,978	23,682	500,736	315,310	1,084,271	5	
1,926	23,304	629,040	283,867	1,183,611	31	
1,815	26,789	537,595	324,602	1,112,238	427	
1,837	16,084	609,806	309,045	1,098,995	230	
1,781	19,936	429,019	421,329	1,073,594	342	

醫療業 Medical Industry	傳播業 Broadcasting	營建業 Construction	公用事業 Utilities	承攬契據 Construction agreements	財產契據 Real Estate Deed	其他 Others
165,500	1,714	33,683	28,150	457,769	322,703	864,923
172,347	1,604	33,412	34,452	488,171	312,498	787,846
56,163	532	10,402	10,468	122,186	77,943	250,936
84,358	838	16,705	15,017	220,615	152,537	388,506
143,259	1,406	27,032	29,469	367,039	231,059	669,006
172,347	1,604	33,412	34,452	488,171	312,498	787,846

表 12 娛 樂 稅 稅 源

單位：家、件數

年 度 (月) 別 Fiscal Year (Month)			合 計 Total	電 影 Movies	歌 廳 Sing Halls	撞 球 場 Billiards Halls	保 齡 球 Bowling Alleys
97	年 度	FY2008	1,781	37	1	—	—
98	年 度	FY2009	1,718	33	1	—	—
99	年 度	FY2010	1,671	36	1	—	—
100	年 度	FY2011	1,677	36	1	—	—
101	年 度	FY2012	1,624	37	1	—	—
102	年 度	FY2013	1,615	37	1	—	—
103	年 度	FY2014	1,549	37	2	—	—
104	年 度	FY2015	1,490	36	2	—	—
105	年 度	FY2016	1,545	37	2	—	—
106	年 度	FY2017	1,883	38	2	—	—
1	月	Jan.	1,543	38	2	—	—
2	月	Feb.	1,483	38	2	—	—
3	月	Mar.	1,457	38	2	—	—
4	月	Apr.	1,476	38	2	—	—
5	月	May	1,534	38	2	—	—
6	月	June	1,568	38	2	—	—
7	月	July	1,576	38	2	—	—
8	月	Aug.	1,637	38	2	—	—
9	月	Sep.	1,649	38	2	—	—
10	月	Oct.	1,900	38	2	—	—
11	月	Nov.	1,830	38	2	—	—
12	月	Dec.	1,883	38	2	—	—

資料來源：依據本處機會稅科資料編製。

Table 12. Sources of Amusement Tax

Unit : Case

高爾夫球練習場 Golf	舞廳 (場) Dance Halls	電子遊戲機 Electric Toys	有節目餐飲業 Entertainment Restaurants	MTV等視聽業 MTV Audiovisual Services	臨時公演 Temp. Public Shows	其他 Others
14	32	78	29	1,243	70	277
14	27	78	31	1,184	76	274
14	28	70	37	1,143	73	269
14	26	68	36	1,158	78	260
16	21	65	37	1,102	89	256
19	22	53	41	1,065	127	250
17	22	54	42	1,009	120	246
14	22	54	45	951	122	244
12	21	56	48	916	172	281
12	21	62	46	885	289	528
13	21	55	47	915	172	280
13	21	57	47	912	102	291
13	22	58	45	905	77	297
13	21	59	46	902	96	299
13	21	59	44	901	145	311
13	23	60	47	890	177	318
13	22	65	46	892	151	347
13	22	65	47	886	170	394
13	22	62	48	888	129	447
13	20	61	47	885	348	486
13	21	62	46	889	252	507
12	21	62	46	885	289	528

表 13 違章漏稅案件處理及財務罰鍰執行情形

單位 { 件數：件
金額：新臺幣千元

年度及稅目別 Fiscal Year & Item of Tax	受理情形 No. of Cases Accepted			本期審理情形	
	合計 Total	上期未 結件數 Unclosed Cases of Last Term	本期受 理件數 Cases Accepted in this Term	依法免 議件數 Cases Not Indictable	依法免 罰件數 Fine Free Cases
97 年 度 FY2008	6,799	143	6,656	368	36
98 年 度 FY2009	7,725	37	7,688	398	186
99 年 度 FY2010	14,445	147	14,298	576	2,976
100 年 度 FY2011	7,936	260	7,676	542	1,034
101 年 度 FY2012	6,042	72	5,970	382	726
102 年 度 FY2013	5,635	44	5,591	289	387
103 年 度 FY2014	3,597	61	3,536	221	268
104 年 度 FY2015	6,958	28	6,930	193	559
105 年 度 FY2016	9,103	119	8,984	204	1,761
106 年 度 FY2017	17,677	118	17,559	204	4,732
土 地 稅 Land Tax	5	—	5	1	—
房 屋 稅 House Tax	—	—	—	—	—
使 用 牌 照 稅 Vehicle License Tax	17,602	118	17,484	201	4,714
契 稅 Deed Tax	1	—	1	1	—
印 花 稅 Stamp Tax	32	—	32	—	1
娛 樂 稅 Amusement Tax	37	—	37	1	17

資料來源：依據本處稅務管理科資料編製。

Table 13. The Management of Cases of Tax Evasion Against Law
and Execution Status of Fine

Unit: { Case
N.T.\$1,000

Cases Interrogated in This Term			本期繳納及移送情形 Cases of Find Paid and Transferred to Law Court in This Term					
處罰 Cases Fined		未結 件數 Cases Unclosed	合計 Total		自行繳納 Paid		移送執行 Transferred to Law Court	
件數 Cases	金額 Amount		件數 Cases	金額 Amount	件數 Cases	金額 Amount	件數 Cases	金額 Amount
6,358	187,241	37	6,649	141,108	3,567	56,162	3,082	84,946
6,994	142,501	147	9,527	177,289	2,991	56,029	6,536	121,260
10,633	230,263	260	13,542	253,119	4,703	42,138	8,839	210,981
6,288	101,053	72	13,282	213,703	4,897	31,559	8,385	182,144
4,890	81,560	44	11,727	178,053	4,092	23,740	7,635	154,313
4,898	68,455	61	11,152	162,532	3,543	27,326	7,609	135,206
3,080	49,005	28	7,755	131,268	1,671	11,301	6,084	119,967
6,087	40,910	119	5,805	85,539	796	3,118	5,009	82,421
7,020	43,564	118	7,440	93,590	1,007	1,670	6,433	91,920
12,692	64,583	49	6,740	61,607	1,346	1,248	5,394	60,359
4	5,966	—	—	—	—	—	—	—
—	—	—	—	—	—	—	—	—
12,640	57,918	47	6,703	60,994	1,312	791	5,391	60,203
—	—	—	—	—	—	—	—	—
31	295	—	21	162	19	156	2	6
17	404	2	16	450	15	301	1	149

表 13 違章漏稅案件處理及財務罰鍰執行情形 (續)

單位 { 件數：件
金額：新臺幣千元

年度及稅目別 Fiscal Year & Item of Tax	更正註銷案件 Case of Revising or Cancelling		本 期	
			合計 Total	
	件 數 Cases	金 額 Amount	件 數 Cases	金 額 Amount
97 年 度 FY2008	- 908	30,551	2,576	59,340
98 年 度 FY2009	-1,399	24,282	4,341	118,649
99 年 度 FY2010	-1,745	15,011	6,478	148,069
100 年 度 FY2011	-1,890	38,177	9,270	219,195
101 年 度 FY2012	-3,553	1,865	6,560	150,690
102 年 度 FY2013	6	33,485	6,996	136,684
103 年 度 FY2014	1,783	35,519	6,881	127,183
104 年 度 FY2015	2,093	57,071	5,540	118,027
105 年 度 FY2016	15	419	5,360	80,991
106 年 度 FY2017	11	158	4,971	72,232
土 地 稅 Land Tax	—	—	1	10,823
房 屋 稅 House Tax	—	—	—	—
使 用 牌 照 稅 Vehicle License Tax	11	158	4,969	61,260
契 稅 Deed Tax	—	—	—	—
印 花 稅 Stamp Tax	—	—	—	0
娛 樂 稅 Amusement Tax	—	—	1	149

Table 13. The Management of Cases of Tax Evasion Against Law and Execution Status of Fine (Cont.)

Unit: { Case
N.T.\$1,000

執行情形 Cases Executed in This Term						截至本期未執行案件 Cases Unexecuted	
移送繳納 Fined Paid		發給執行憑證 Giving Executive Evidence		移送駁回或撤回 Cases of Withdrawn or Rejected			
件數 Cases	金額 Amount	件數 Cases	金額 Amount	件數 Cases	金額 Amount	件數 Cases	金額 Amount
813	17,424	1,695	39,871	68	2,045	3,249	638,025
1,405	26,010	2,829	90,581	107	2,058	5,444	640,636
1,750	31,268	4,584	113,901	144	2,900	7,805	703,548
2,118	41,503	7,019	173,858	133	3,834	5,866	180,815
1,816	32,995	4,616	114,427	128	3,268	6,941	184,438
1,938	29,024	4,976	105,960	82	1,700	7,554	182,960
1,877	28,647	4,927	97,115	77	1,421	6,304	165,557
1,376	21,416	4,129	95,819	35	792	5,673	126,496
1,560	16,011	3,763	64,543	37	437	6,756	136,855
1,677	12,953	3,184	58,151	110	1,128	7,140	124,357
—	—	1	10,823	—	—	—	—
—	—	—	—	—	—	—	—
1,677	12,953	3,182	47,179	110	1,128	7,133	105,139
—	—	—	—	—	—	—	—
—	0	—	—	—	—	5	19,053
—	—	1	149	—	—	2	164

表 14 各項稅捐滯納案件移送執行情形

金額單位：新臺幣元

年度及稅目別 Fiscal Year & Item of Tax	移送執行數① Executed cases		執行徵起數(1) Executive Levied Tax		掣發債權憑證數(2) Giving Executive Evidence	
	件數 Cases	金額 Amount	件數 Cases	金額 Amount	件數 Cases	金額 Amount
97 年度 FY2008	76,381	1,024,567,477	39,497	611,348,255	50,078	439,371,016
98 年度 FY2009	86,642	1,070,882,804	38,327	667,009,679	51,666	481,404,542
99 年度 FY2010	80,769	842,479,642	35,215	573,963,337	54,967	843,341,510
100 年度 FY2011	59,383	727,698,688	32,371	714,712,214	53,687	823,659,132
101 年度 FY2012	55,501	546,330,038	26,548	438,195,809	25,761	262,966,626
102 年度 FY2013	46,641	420,820,836	26,114	331,664,615	23,141	176,463,048
103 年度 FY2014	44,654	411,498,960	25,496	288,609,636	20,152	162,299,899
104 年度 FY2015	43,075	428,150,709	26,151	300,982,249	17,003	180,861,988
105 年度 FY2016	48,613	683,536,545	29,212	333,979,945	15,495	298,700,331
106 年度 FY2017	46,480	573,372,660	29,353	377,759,399	12,038	100,871,148
地 價 稅 Land Value Tax	11,209	150,144,429	8,199	135,486,472	1,951	17,761,742
土 地 增 值 稅 Land Value Increment Tax	38	49,129,138	14	30,116,151	1	649,108
房 屋 稅 House Tax	8,342	92,601,250	6,657	40,205,740	613	14,047,661
使 用 牌 照 稅 Vehicle License Tax	25,086	198,495,979	14,159	124,874,226	8,092	52,800,470
契 稅 Deed Tax	17	867,205	14	504,366	4	27,936
印 花 稅 Stamp Tax	—	—	—	—	—	—
娛 樂 稅 Amusement Tax	1,788	4,135,596	310	893,340	1,377	2,908,532
罰 鍰② Fine	—	77,999,063	—	45,679,104	—	12,675,699

資料來源：依據本處稅務管理科資料編製。

附 註：①包括以前年度移送未執行結轉數。

②罰鍰係指本稅以外之短估金、滯(怠)報金、滯納金及加計利息等之合計數，為附加稅，故不計件數。

③101年度以前係指結案數。

Table 14. The Status of Delayed Case Transferred to Execution

Unit : N.T.\$1

撤退案數(3)		稅捐處清理數③(1+2+3=4)		移送尚未執行數	
Cases of Withdrawn		Closed Cases		Unexecuted Cases	
件數 Cases	金額 Amount	件數 Cases	金額 Amount	件數 Cases	金額 Amount
2,338	104,810,618	91,913	1,155,529,889	92,189	3,380,106,899
1,977	35,843,492	91,970	1,184,257,713	83,718	3,209,836,714
1,851	24,838,280	92,033	1,442,143,127	70,335	2,560,047,010
933	15,260,562	86,991	1,553,631,908	41,370	1,603,167,185
1,017	14,761,965	53,326	715,924,400	42,845	1,395,183,086
520	6,656,743	49,775	514,784,406	4,307	151,801,244
318	3,398,005	45,966	454,307,540	36,989	1,234,841,497
221	6,775,138	43,375	488,619,375	35,932	1,162,575,765
249	5,579,121	44,956	638,259,397	38,910	1,171,977,797
236	4,888,263	41,627	483,518,810	42,884	1,240,273,298
95	1,911,818	10,245	155,160,032	10,002	391,238,569
2	1,222,632	17	31,987,891	48	368,807,837
38	169,599	7,308	54,423,000	6,786	113,801,840
89	894,735	22,340	178,569,431	24,231	177,990,220
—	—	18	532,302	5	200,823
—	—	—	—	11	130,038
12	26,220	1,699	3,828,092	1,801	8,164,969
—	663,259	—	59,018,062	—	179,939,002

表 15 查(核)定開徵數及未徵數情形

單位 { 件數：件
金額：新臺幣千元

一. 本年度

年度及稅目別 Fiscal Year & Item of Tax	查(核)定開徵數 Opening Collection for Assessed(Verified) (1)		實徵數 Tax Collected (2)		減免註銷數 Cancelled (3)		逾徵收 期間數 Overdue (4)	
	件數 Cases	金額 Amount	件數 Cases	金額 Amount	件數 Cases	金額 Amount	件數 Cases	金額 Amount
	102 年度 FY2013	3,061,761	68,463,016	2,974,908	64,981,290	25,022	2,069,634	—
103 年度 FY2014	3,098,137	70,702,817	3,005,973	66,230,222	32,645	3,324,245	—	—
104 年度 FY2015	3,177,942	81,454,591	3,087,289	75,689,692	26,624	4,651,618	—	—
105 年度 FY2016	3,169,683	79,294,537	3,077,997	74,121,987	26,016	3,536,979	—	—
106 年度 FY2017	3,203,560	78,253,380	3,103,387	73,520,588	27,261	3,204,568	—	—
地價稅 Land Value Tax	907,959	30,145,544	871,899	29,173,528	2,437	371,215	—	—
土地增值稅 Land Value Increment Tax	48,616	18,426,905	43,718	15,458,250	3,627	2,321,674	—	—
房屋稅 House Tax	1,064,960	15,746,277	1,051,713	15,592,900	4,975	77,035	—	—
使用牌照稅 Vehicle License Tax	1,016,672	7,814,600	987,226	7,420,361	9,058	272,003	—	—
契稅 Deed Tax	35,356	1,620,121	32,914	1,492,438	1,855	101,808	—	—
印花稅 Stamp Tax	99,145	4,178,908	91,226	4,102,084	4,783	51,562	—	—
娛樂稅 Amusement Tax	20,044	258,869	18,922	255,409	333	1,502	—	—
罰鍰 Fine	10,808	62,156	5,769	25,618	193	7,768	—	—

資料來源：依據本處稅務管理科資料編製。

附註：1.本表以開徵始日為統計基礎。

2.實徵數之件數及金額未包含實徵當查定部分。

Table 15. The Management of Opening Collection for Assessed (Verified) and of Tax Not Collected

Unit: { Case
N.T.\$1,000

1. Current Year

逾核課期間數 Excess Assessment (5)		未徵數餘額 Balance of Tax Not Collected					
		合計 Total (6)=(1)-(2)-(3)-(4)-(5)		繳款書未送達 未徵數 Have Not Been Served the Payment Notice		未逾限繳日 未徵數 Have Not Exceeded the Deadline of Payment	
件數 Cases	金額 Amount	件數 Cases	金額 Amount	件數 Cases	金額 Amount	件數 Cases	金額 Amount
13	58	61,818	1,412,034	28,370	668,134	15,015	430,539
9	141	59,510	1,148,209	27,334	299,768	14,530	499,542
7	101	64,022	1,113,179	28,309	222,583	16,100	595,051
4	30	65,666	1,635,541	26,180	360,430	17,003	842,333
8	47	72,904	1,528,177	28,953	394,475	19,543	660,822
—	—	33,623	600,801	26,270	194,833	5,760	122,337
—	—	1,271	646,981	599	180,518	669	465,643
—	—	8,272	76,342	807	3,565	2,503	11,269
7	44	20,381	122,192	734	3,257	5,713	15,342
—	—	587	25,875	158	9,244	426	16,430
—	—	3,136	25,262	137	2,044	2,998	23,196
—	—	789	1,958	162	565	150	334
1	3	4,845	28,767	86	448	1,324	6,272

表 15 查(核)定開徵數及未徵數情形 (續1)

單位 { 件數：件
金額：新臺幣千元

一.本年度

年度及稅目別 Fiscal Year & Item of Tax	未徵數餘額							
	行政救濟 未徵數 Administrative Remedies		分期繳納 未徵數 Pay by Stages		特殊原因 未徵數 Special Reason		欠 小計 Subtotal	
	件數 Cases	金額 Amount	件數 Cases	金額 Amount	件數 Cases	金額 Amount	件數 Cases	金額 Amount
102 年度 FY2013	96	70,784	—	—	232	124	18,105	242,454
103 年度 FY2014	89	115,982	—	—	231	230	17,326	232,689
104 年度 FY2015	164	123,635	—	—	257	105	19,192	171,805
105 年度 FY2016	189	116,744	46	28,311	178	155	22,070	287,570
106 年度 FY2017	159	240,328	4	648	211	250	24,034	231,654
地 價 稅 Land Value Tax	61	206,565	4	648	11	2	1,517	76,415
土 地 增 值 稅 Land Value Increment Tax	1	230	—	—	—	—	2	590
房 屋 稅 House Tax	82	33,288	—	—	131	30	4,749	28,190
使 用 牌 照 稅 Vehicle License Tax	10	136	—	—	65	204	13,859	103,253
契 稅 Deed Tax	—	—	—	—	—	—	3	200
印 花 稅 Stamp Tax	—	—	—	—	—	—	1	22
娛 樂 稅 Amusement Tax	—	—	—	—	2	0	475	1,058
罰 鍰 Fine	5	109	—	—	2	13	3,428	21,925

Table 15. The Management of Opening Collection for Assessed (Verified) and of Tax Not Collected (Cont.1)

Unit: { Case
N.T.\$1,000

1. Current Year

Balance of Tax Not Collected							
稅 數				Pending Tax Arrears			
送達未逾滯納期 Service of Notice Has Not Exceeded Delinquency Period		移送執行未結 Transferred to Law Court Not Yet Closed		執行憑證數 Executive Evidence		其 他 Others	
件 數 Cases	金 額 Amount	件 數 Cases	金 額 Amount	件 數 Cases	金 額 Amount	件 數 Cases	金 額 Amount
2,021	16,523	11,911	104,187	603	5,041	3,570	116,703
1,909	71,693	12,504	111,676	1,007	9,670	1,906	39,649
4,480	37,935	11,249	84,569	563	4,158	2,900	45,142
3,964	36,760	14,143	111,609	910	7,207	3,053	131,993
5,018	43,173	15,026	110,325	783	4,151	3,207	74,005
417	15,574	251	1,843	—	—	849	58,998
2	590	—	—	—	—	—	—
498	2,298	3,648	22,989	3	7	600	2,896
3,054	19,963	9,049	72,160	434	2,043	1,322	9,088
—	—	3	200	—	—	—	—
—	—	—	—	—	—	1	22
76	116	310	776	56	117	33	49
971	4,632	1,765	12,356	290	1,985	402	2,952

表 15 查(核)定開徵數及未徵數情形 (續2)

單位 { 件數：件
金額：新臺幣千元

二. 以前年度

年度及稅目別 Fiscal Year & Item of Tax	查(核)定開徵數①		實徵數		減免註銷數		逾徵收 期間數	
	Opening Collection for Assessed(Verified) (1)		Tax Collected (2)		Cancelled (3)		Overdue (4)	
	件數 Cases	金額 Amount	件數 Cases	金額 Amount	件數 Cases	金額 Amount	件數 Cases	金額 Amount
102 年度 FY2013	168,974	3,016,747	76,703	1,146,773	478	75,169	13,596	117,944
103 年度 FY2014	149,916	2,911,044	69,114	947,241	-861	81,493	14,123	120,263
104 年度 FY2015	137,313	2,840,678	67,316	1,027,413	-523	25,530	9,820	101,197
105 年度 FY2016	134,592	2,793,072	67,836	1,132,222	-6	62,161	795	1,480
106 年度 FY2017	142,332	3,222,246	70,997	1,385,485	-2,281	180,311	554	31,584
地 價 稅 Land Value Tax	49,866	1,383,743	32,727	664,300	76	57,032	230	20,138
土 地 增 值 稅 Land Value Increment Tax	1,160	953,544	947	410,717	141	166,315	1	1,017
房 屋 稅 House Tax	13,450	221,124	8,234	94,285	82	1,126	158	10,252
使 用 牌 照 稅 Vehicle License Tax	54,513	327,293	19,159	89,279	166	9,522	150	103
契 稅 Deed Tax	465	26,893	383	22,282	69	4,246	1	12
印 花 稅 Stamp Tax	3,440	30,565	6,400	90,058	-2,980	-59,821	—	—
娛 樂 稅 Amusement Tax	3,916	13,047	532	1,259	-33	-17	7	9
罰 鍰 Fine	15,522	266,036	2,615	13,304	198	1,907	7	52

資料來源：根據本處稅務管理科資料編製。

附 註：①係原開徵始日在上年度12月31日以前之查(核)定開徵稅款，未逾徵收期間而仍未徵起者。

Table 15. The Management of Opening Collection for Assessed (Verified) and of Tax Not Collected (Cont.2)

2. Previous Year

Unit: { Case
N.T.\$1,000

逾核課期間數 Excess Assessment (5)		未徵數餘額 Balance of Tax Not Collected					
		合計 Total (6)=(1)-(2)-(3)-(4)-(5)		繳款書未送達 未徵數 Have Not Been Served the Payment Notice		未逾限繳日 未徵數 Have Not Exceeded the Deadline of Payment	
件數 Cases	金額 Amount	件數 Cases	金額 Amount	件數 Cases	金額 Amount	件數 Cases	金額 Amount
295	4,124	77,902	1,672,737	672	63,134	157	2,656
282	10,341	67,258	1,751,706	721	47,788	275	234,801
313	7,896	60,387	1,678,641	638	19,240	342	298,214
267	3,703	65,700	1,593,507	660	21,573	106	2,880
238	3,198	72,824	1,621,669	698	16,285	316	17,514
205	2,963	16,628	639,310	535	10,168	30	855
—	—	71	375,495	16	5,096	1	261
3	1	4,973	115,459	24	384	140	15,628
27	130	35,011	228,257	110	403	130	632
—	—	12	353	—	—	2	1
—	—	20	328	6	198	—	—
—	—	3,410	11,796	—	—	—	—
3	103	12,699	250,670	7	35	13	137

表 15 查(核)定開徵數及未徵數情形 (續3完)

單位 { 件數：件
金額：新臺幣千元

二.以前年度

年度及稅目別 Fiscal Year & Item of Tax	未徵數餘額							
	行政救濟 未徵數 Administrative Remedies		分期繳納 未徵數 Pay by Stages		特殊原因 未徵數 Special Reason		欠	
							小計	
	件數 Cases	金額 Amount	件數 Cases	金額 Amount	件數 Cases	金額 Amount	件數 Cases	金額 Amount
102 年度 FY2013	206	64,554	—	—	4,512	24,114	72,264	1,517,626
103 年度 FY2014	197	37,379	—	—	3,713	20,956	62,352	1,410,783
104 年度 FY2015	28	61,213	—	—	3,049	20,599	56,330	1,279,375
105 年度 FY2016	112	158,663	—	—	2,054	4,056	62,768	1,406,336
106 年度 FY2017	56	157,365	—	—	1,707	3,933	70,047	1,426,572
地 價 稅 Land Value Tax	33	156,420	—	—	1,119	2,921	14,911	468,944
土 地 增 值 稅 Land Value Increment Tax	3	679	—	—	—	—	51	369,460
房 屋 稅 House Tax	7	0	—	—	244	51	4,558	99,397
使 用 牌 照 稅 Vehicle License Tax	11	237	—	—	315	805	34,445	226,180
契 稅 Deed Tax	—	—	—	—	—	—	10	352
印 花 稅 Stamp Tax	—	—	—	—	3	0	11	130
娛 樂 稅 Amusement Tax	—	—	—	—	9	2	3,401	11,794
罰 鍰 Fine	2	29	—	—	17	154	12,660	250,315

Table 15. The Management of Opening Collection for Assessed (Verified) and of Tax Not Collected (Cont.3 End)

2. Previous Year

Unit: { Case
N.T.\$1,000

Balance of Tax Not Collected							
Pending Tax Arrears							
稅 數		移送執行未結		執行憑證數		其 他	
送達未逾滯納期 Service of Notice Has Not Exceeded Delinquency Period		Transferred to Law Court Not Yet Closed		Executive Evidence		Others	
件 數 Cases	金 額 Amount	件 數 Cases	金 額 Amount	件 數 Cases	金 額 Amount	件 數 Cases	金 額 Amount
30	364	14,025	952,511	58,119	563,693	181	1,711
66	584	13,012	912,598	49,093	496,408	181	1,193
94	2,095	12,404	856,384	43,632	416,342	200	4,553
63	365	14,706	849,014	47,807	555,974	192	982
71	490	18,948	870,600	50,818	553,061	210	2,421
21	267	7,263	353,493	7,518	113,517	109	1,668
—	—	45	368,518	4	939	2	3
—	—	2,107	45,061	2,415	53,930	36	405
49	199	7,019	52,823	27,322	172,831	55	326
—	—	2	0	8	352	—	—
—	—	11	130	—	—	—	—
—	—	476	4,537	2,925	7,257	—	—
1	24	2,025	46,036	10,626	204,235	8	20

表 16 各項稅捐現行稅率表

稅別	課 徵 標 的 及 稅 率			
地 價 稅	地價稅累進起點地價，以本市土地 7 公畝之平均地價為準。但不包括工業用地、礦業用地、農業用地及免稅土地在內。			
	土地類別	級別	累 進 地 價 級 距	稅 率
	私 有 一 般 土 地	1	未超過累進起點地價部分	10 ‰
		2	超過累進起點地價未達 5 倍者，其超過部分	15 ‰
		3	超過累進起點地價 5 倍至 10 倍者，其超過部分	25 ‰
		4	超過累進起點地價 10 倍至 15 倍者，其超過部分	35 ‰
		5	超過累進起點地價 15 倍至 20 倍者，其超過部分	45 ‰
		6	超過累進起點地價 20 倍以上者，其超過部分	55 ‰
	公 有 土 地			10 ‰
	工業用地、加油站、停車場等事業直接使用之土地等			10 ‰
公 共 設 施 保 留 地			6 ‰	
自用住宅、國民住宅及勞工宿舍用地			2 ‰	

表 16 各項稅捐現行稅率表（續 1）

稅別	稅級別	計 算 公 式
土 地 增 值 稅	第一級	應徵稅額＝土地漲價總數額〔超過原規定地價或前次移轉時申報現值（按臺灣地區消費者物價總指數調整後）未達百分之一百者〕×稅率（20%）。
	第二級	<p>應徵稅額＝土地漲價總數額【超過原規定地價或前次移轉時申報現值（按臺灣地區消費者物價總指數調整後）在百分之一百以上未達百分之二百者】×【稅率（30%）－〔（30%－20%）×減徵率〕】－累進差額（按臺灣地區消費者物價總指數調整後之原規定地價或前次移轉現值×A）。</p> <p>註：持有土地年限未超過 20 年者，無減徵，A 為 0.10。 持有土地年限超過 20 年以上者，減徵率為 20%，A 為 0.08。 持有土地年限超過 30 年以上者，減徵率為 30%，A 為 0.07。 持有土地年限超過 40 年以上者，減徵率為 40%，A 為 0.06。</p>
	第三級	<p>應徵稅額＝土地漲價總數額【超過原規定地價或前次移轉時申報現值（按臺灣地區消費者物價總指數調整後）在百分之二百以上者】×【稅率（40%）－〔（40%－20%）×減徵率〕】－累進差額（按臺灣地區消費者物價總指數調整後之原規定地價或前次移轉現值×B）。</p> <p>註：持有土地年限未超過 20 年者，無減徵，B 為 0.30。 持有土地年限超過 20 年以上者，減徵率為 20%，B 為 0.24。 持有土地年限超過 30 年以上者，減徵率為 30%，B 為 0.21。 持有土地年限超過 40 年以上者，減徵率為 40%，B 為 0.18。</p>
自用住宅用地稅率一律 10%		

表 16 各項稅捐現行稅率表 (續 2)

稅別	課 徵 標 的	稅 率
房 屋 稅	一、住家用房屋：	
	(一)供自住或公益出租人出租使用，按其房屋現值課徵。	1.2 %
	(二)持有本市非自住之其他住家用房屋在 2 戶以下者，按其房屋現值課徵。	2.4 %
	(三)持有本市非自住之其他住家用房屋在 3 戶以上者，按其房屋現值課徵。	3.6 %
	(四)下列房屋除法規另有規定外，採單一稅率，不納入前 2 項戶數計算：	
	1.公有房屋供住家使用，按其房屋現值課徵。	1.5 %
	2.出租供符合本市社會住宅承租資格者使用，且持有主管機關核發之出租人核定函者，按其房屋現值課徵。	1.5 %
	3.經勞工主管機關核發證明文件之勞工宿舍者，按其房屋現值課徵。	1.5 %
	4.公立學校之學生宿舍，由民間機構與主辦機關簽訂投資契約，投資興建並租與該校學生作宿舍使用，且約定於營運期間屆滿後，移轉該宿舍之所有權予政府者，按其房屋現值課徵。	1.5 %
	5.共同共有者，除共有人符合自住者，其潛在應有部分外，按其房屋現值課徵。	2.4 %
	二、非住家用房屋：	
(一)供營業、私人醫院、診所或自由職業事務所使用，按其房屋現值課徵。	3 %	
(二)供人民團體及其他性質可認定為非供營業用，按其房屋現值課徵。	2 %	

表 16 各項稅捐現行稅率表 (續 4)

稅別	稅額 (元) 總排量 (立方公分)	車輛 種類	小客車		大客車	貨車	機車
			自用	營業	全年	全年	全年
			全年	全年			
使 用 牌 照 稅	150 以下		—	—	—	—	0
	151~ 250		—	—	—	—	800
	251~ 500		1,620	900	—	900	1,620
	501~ 600		2,160	1,260	1,080	1,080	2,160
	601~ 1,200		4,320	2,160	1,800	1,800	4,320
	1,201~ 1,800		7,120	3,060	2,700	2,700	7,120
	1,801~ 2,400		11,230	6,480	3,600	3,600	(1801c.c.以上)11,230
	2,401~ 3,000		15,210	9,900	4,500	4,500	
	3,001~ 3,600	}	28,220	16,380	5,400	5,400	
	3,601~ 4,200				6,300	6,300	
	4,201~ 4,800	}	46,170	24,300	7,200	7,200	
	4,801~ 5,400				8,100	8,100	
	5,401~ 6,000	}	69,690	33,660	9,000	9,000	
	6,001~ 6,600				9,900	9,900	
	6,601~ 7,200	}	117,000	44,460	10,800	10,800	
	7,201~ 7,800				11,700	11,700	
	7,801~ 8,400	}	151,200	56,700	12,600	12,600	
	8,401~ 9,000				13,500	13,500	
	9,001~ 9,600				14,400	14,400	
9,601~ 10,200				15,300	15,300		
10,201 以上				16,200	16,200		

臨時牌照	
車別	每日稅額
小客車	41
大客車	23
貨車	22
曳引車	28
機車	5

試車牌照	
車別	每日稅額
小客車	414
機車	30

附註：1. 曳引車之稅額按貨車稅額加徵 30%。

2. 小客貨兩用車之稅額按自用小客車之稅額課徵。

3. 自用車全年 1 期，營業車全年分上、下 2 期課徵。

表 16 各項稅捐現行稅率表 (續 5)

稅別	車輛種類	稅額 (元)		用途	
		馬達最大馬力		自用	營業
		英制馬力(HP)	公制馬力(PS)		
使 用 牌	完全以電能為動力之電動小客車 (每車乘人座位 9 人以下者)	38 以下	38.6 以下	1,620	900
		38.1~ 56	38.7~ 56.8	2,160	1,260
		56.1~ 83	56.9~ 84.2	4,320	2,160
		83.1~182	84.3~184.7	7,120	3,060
		182.1~262	184.8~265.9	11,230	6,480
		262.1~322	266.0~326.8	15,210	9,900
		322.1~414	326.9~420.2	28,220	16,380
		414.1~469	420.3~476.0	46,170	24,300
		469.1~509	476.1~516.6	69,690	33,660
		509.1 以上	516.7 以上	117,000	44,460
照 稅	完全以電能為動力之 電動大客車及貨車	138 以下	140.1 以下		4,500
		138.1~200	140.2~203.0		6,300
		200.1~247	203.1~250.7		8,100
		247.1~286	250.8~290.3		9,900
		286.1~336	290.4~341.0		11,700
		336.1~361	341.1~366.4		13,500
		361.1 以上	366.5 以上		15,300
完全以電能為動力 之電動機車	12 以下	12.2 以下		0	
	12.1-20	12.3-20.3		800	
	20.1-45	20.4-45.7		1,620	

附註：臺北市政府於 104 年 3 月 3 日公告，本市完全以電能為動力之電動汽車，自 101 年 1 月 6 日起至 107 年 1 月 5 日止免徵使用牌照稅。

表 16 各項稅捐現行稅率表 (續 6)

稅別	課 徵 標 的	稅 率
娛 樂 稅	一、舞廳、舞場	25 %
	二、電影	
	1. 外國語片 { (1)市區繁榮地帶	2.5 %
	(2)市區偏僻地帶	1.5 %
	(3)郊區	1 %
	2. 本國語片 { (1)市區繁榮地帶	1 %
	(2)市區偏僻地帶	1 %
	(3)郊區	1 %
	三、高爾夫球練習場	2.5 %
	四、職業性歌唱、舞蹈、馬戲、魔術、技藝表演及夜總會之各種表演。	5 %
五、各種競技比賽及其他提供娛樂設施供人娛樂者。	2.5 %	
六、說書、戲劇、音樂演奏及非職業性歌唱、舞蹈等表演。	1.25 %	
契 稅	一、買賣契按契價	6 %
	二、典權契按契價	4 %
	三、交換契按契價	2 %
	四、贈與契按契價	6 %
	五、分割契按契價	2 %
	六、占有契按契價	6 %

表 16 各項稅捐現行稅率表（續 7 完）

稅別	應 稅 憑 證	稅 率 或 稅 額
印花稅	一、銀錢收據： 指收到銀錢所立之單據、簿、摺。	1. 每件按金額 4‰ 計貼。 2. 收受或領回押標金收據 每件按金額 1‰ 計貼。
	二、承攬契據： 指一方為他方完成一定工作之契據。	每件按金額 1‰ 計貼。
	三、典賣、讓受及分割不動產契據： 指設定典權及買賣、交換、贈與、分割不動產所立向主管機關申請物權登記之契據。	每件按金額 1‰ 計貼。
	四、買賣動產契據： 指買賣動產所立之契據。	每件稅額新臺幣 12 元。

附註：銀錢收據，如係收到票據(支票、匯票、本票)於收據上載明票據名稱及號碼者，免納印花稅。

表 17 各項稅捐劃解分配率

106 年度

單位：百分比

稅目	繳庫別	
	國	庫
地價稅	—	100
土地增值稅	—	100
房屋稅	—	100
使用牌照稅	—	100
契稅	—	100
印花稅	—	100
娛樂稅	—	100

表 18 本處各項稅捐稽徵工作流程圖

(一)地 價 稅



表 18 本處各項稅捐稽徵工作流程圖 (續 1)
(二)土地增值稅



表 18 本處各項稅捐稽徵工作流程圖 (續 2)

(三)房 屋 稅

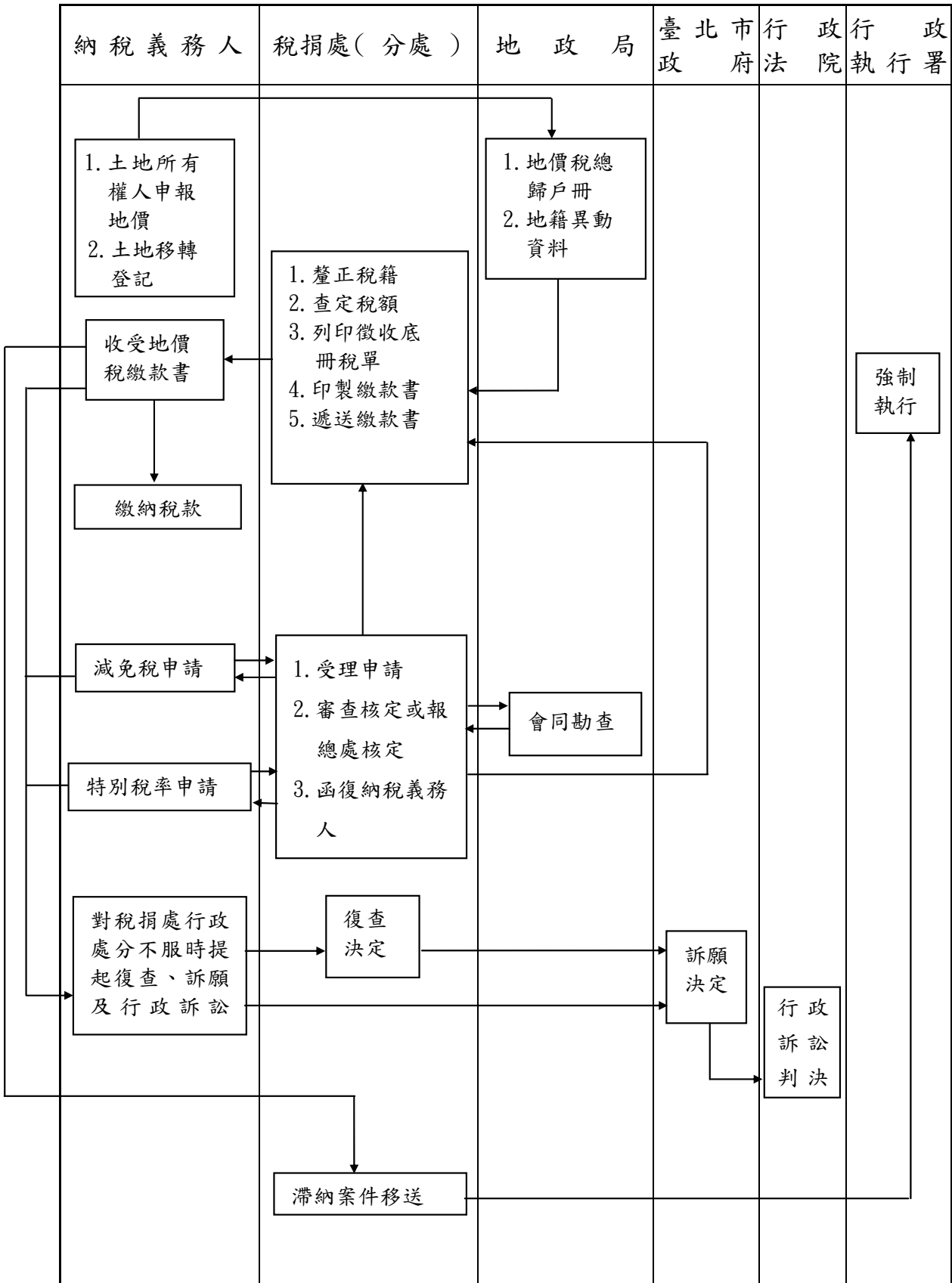

表 18 本處各項稅捐稽徵工作流程圖（續 3）

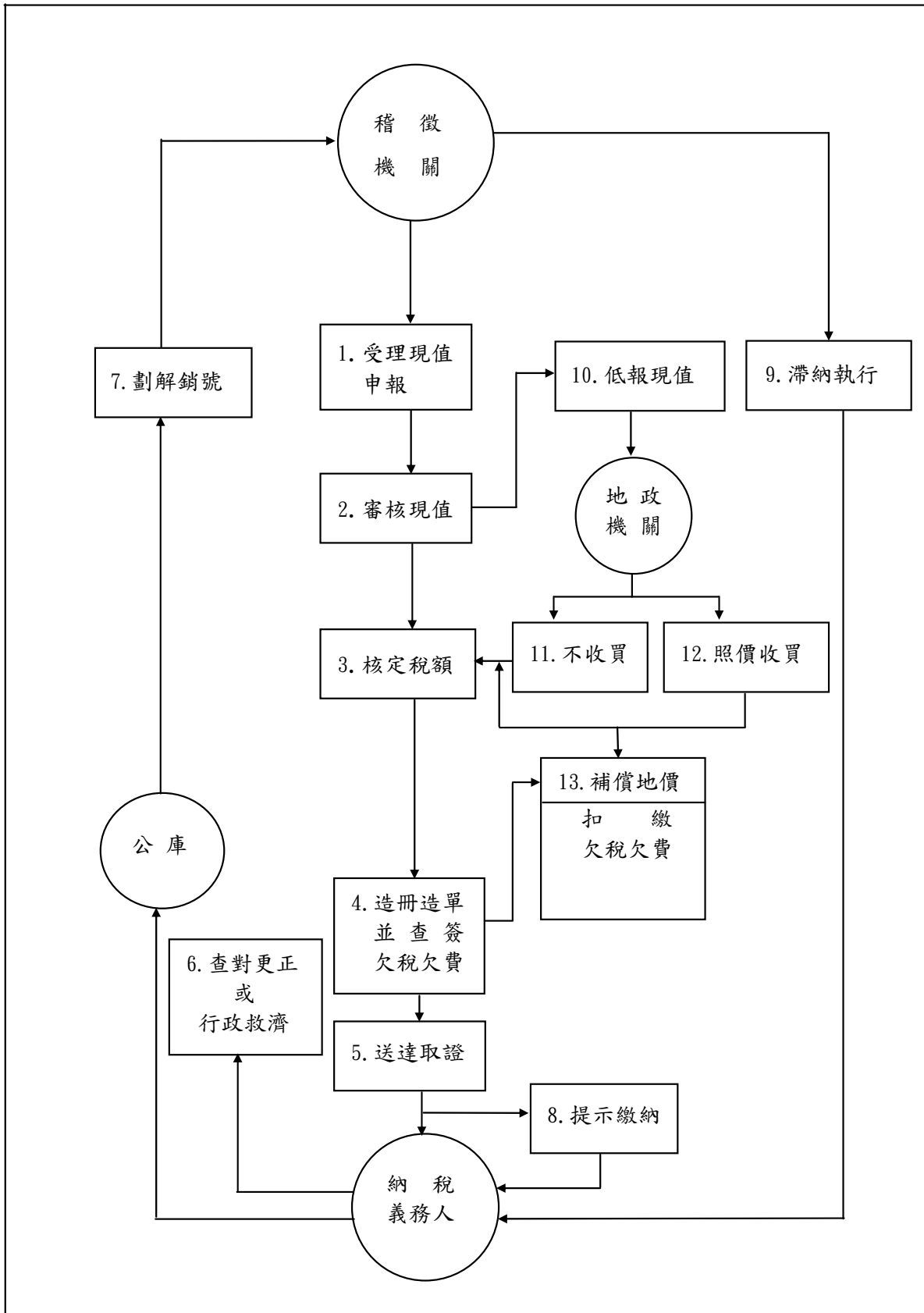
(四)使用牌照稅

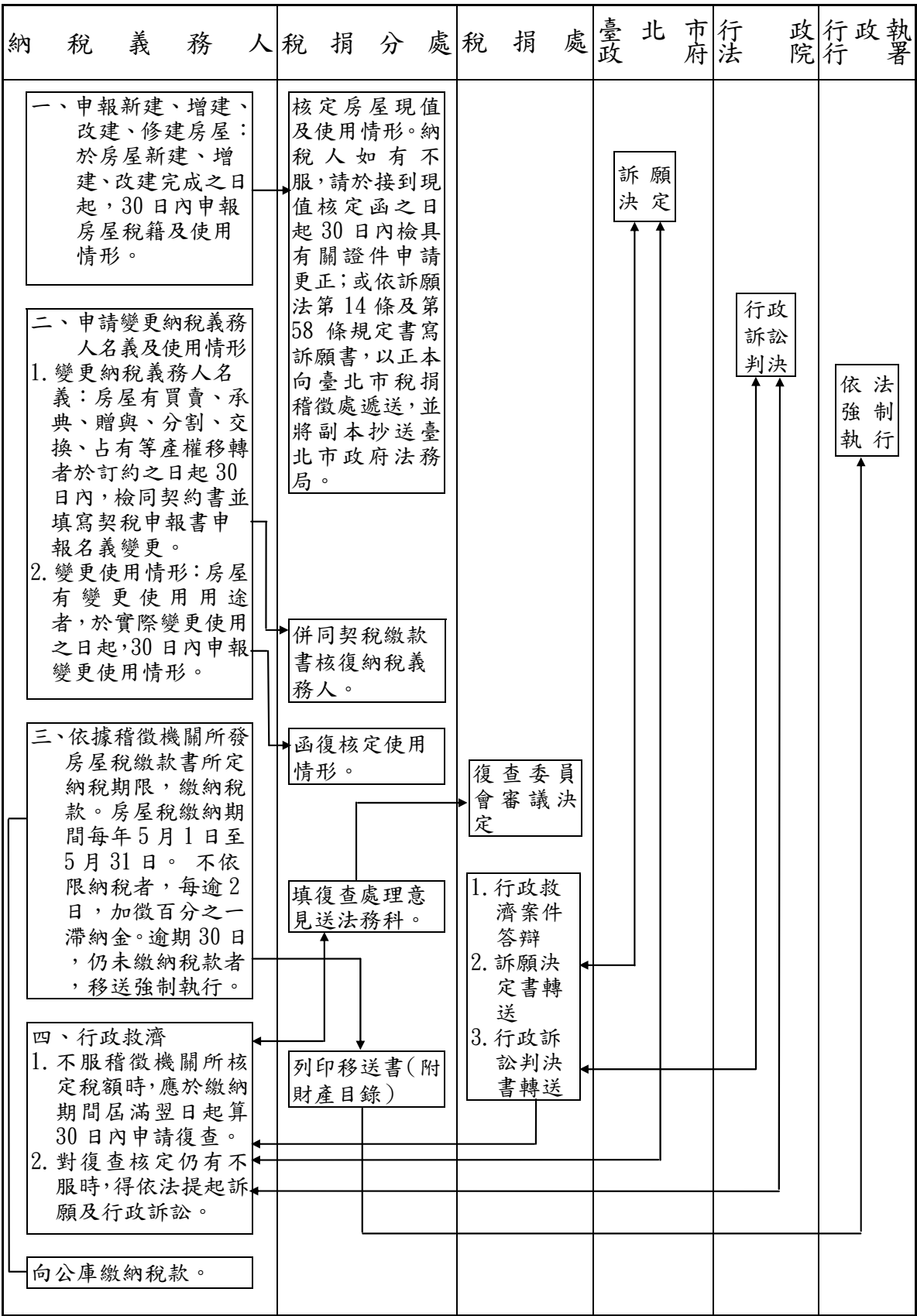

表 18 本處各項稅捐稽徵工作流程圖 (續 4)
(五)契 稅

納 稅 義 務 人	稅 捐 分 處	地 事 務 所	政 務 所 行 政 執 行 署	
<p>不動產所有權移轉契約成立之日起30日內申報契稅</p> <p>↓</p> <p>1. 公定格式契約書 2. 契稅申報書 3. 有關證件 4. 委託代理人申報者應在申報書內加蓋代理人印章</p> <p>↓</p> <p>向公庫繳納稅款後，將繳納通知書第5聯黏貼於買賣等契約書副本隨登記書表送地政機關存查</p> <p>↓</p> <p>未依限繳納稅款，每逾2日，加徵應納稅額百分之一滯納金，逾期30日仍不繳納者移送法院強制執行。</p>	<p>1. 審查契價 2. 核算稅額 3. 編冊造單 4. 遞送稅單</p> <p>↓</p> <p>列印財產目錄及移送書</p>	<p>產 權 變 更 登 記</p>	<p>強制執行</p>	
行 政 救 濟	稅 捐 處	臺 北 市 政 府	臺 北 高 等 行 政 法 院	最 高 行 政 法 院
<p>對核定稅額不服，應於繳納期間屆滿翌日起算30日內，申請復查。</p> <p>↓</p> <p>對復查決定不服</p> <p>↓</p> <p>提 起 訴 願</p> <p>↓</p> <p>行 政 訴 訟</p> <p>↓</p> <p>上 訴</p>	<p>復 查 決 定</p> <p>↓</p> <p>對復查決定不服</p>	<p>訴 願 決 定</p> <p>↓</p> <p>提 起 訴 願</p>	<p>判 決</p> <p>↓</p> <p>行 政 訴 訟</p>	<p>判 決</p> <p>↓</p> <p>上 訴</p>

表 18 本處各項稅捐稽徵工作流程圖 (續 5)
(六)印 花 稅

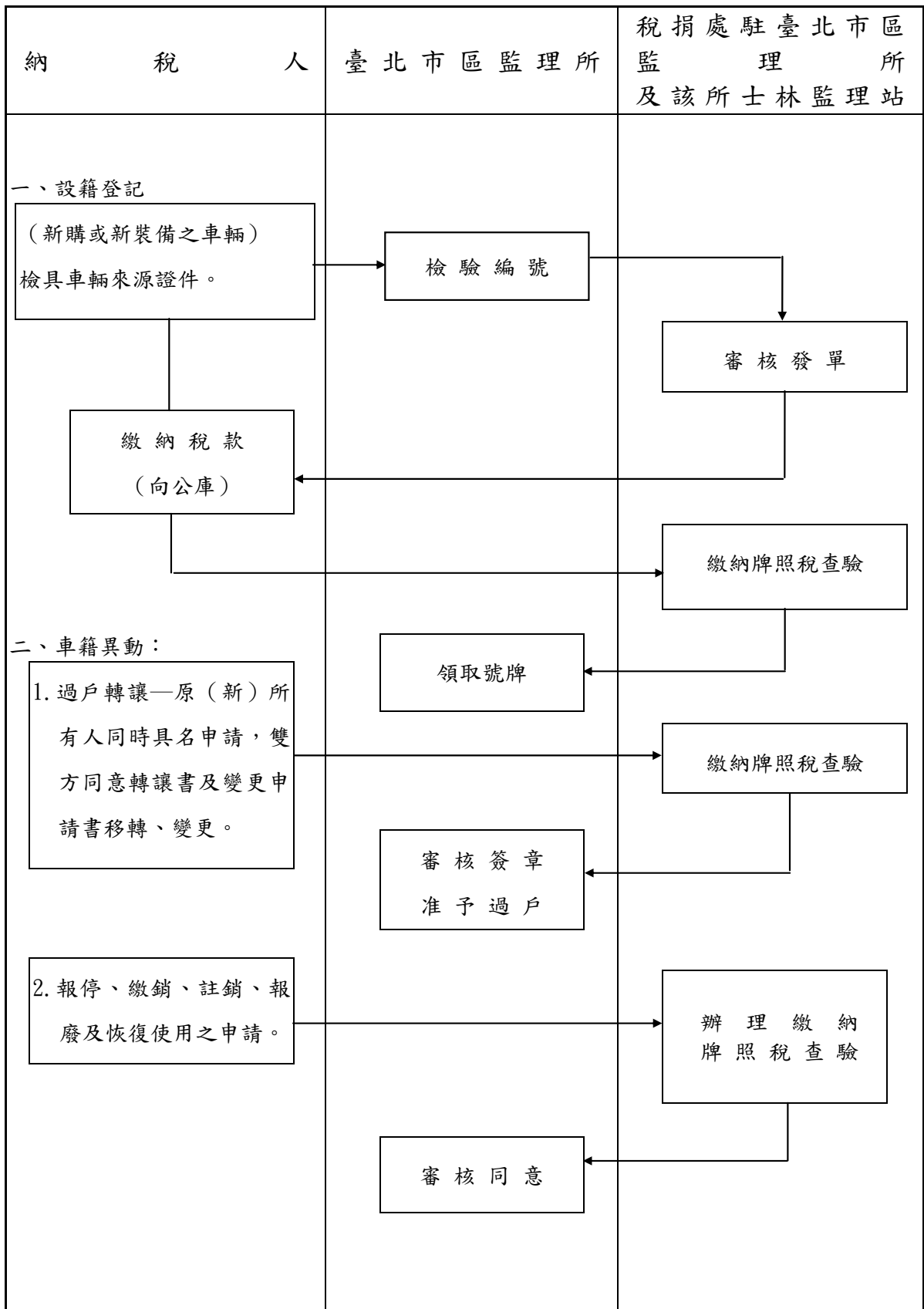

表 18 本處各項稅捐稽徵工作流程圖 (續 6)

(七) 娛樂稅



表 18 本處各項稅捐稽徵工作流程圖 (續 7 完)
(八) 支票退稅

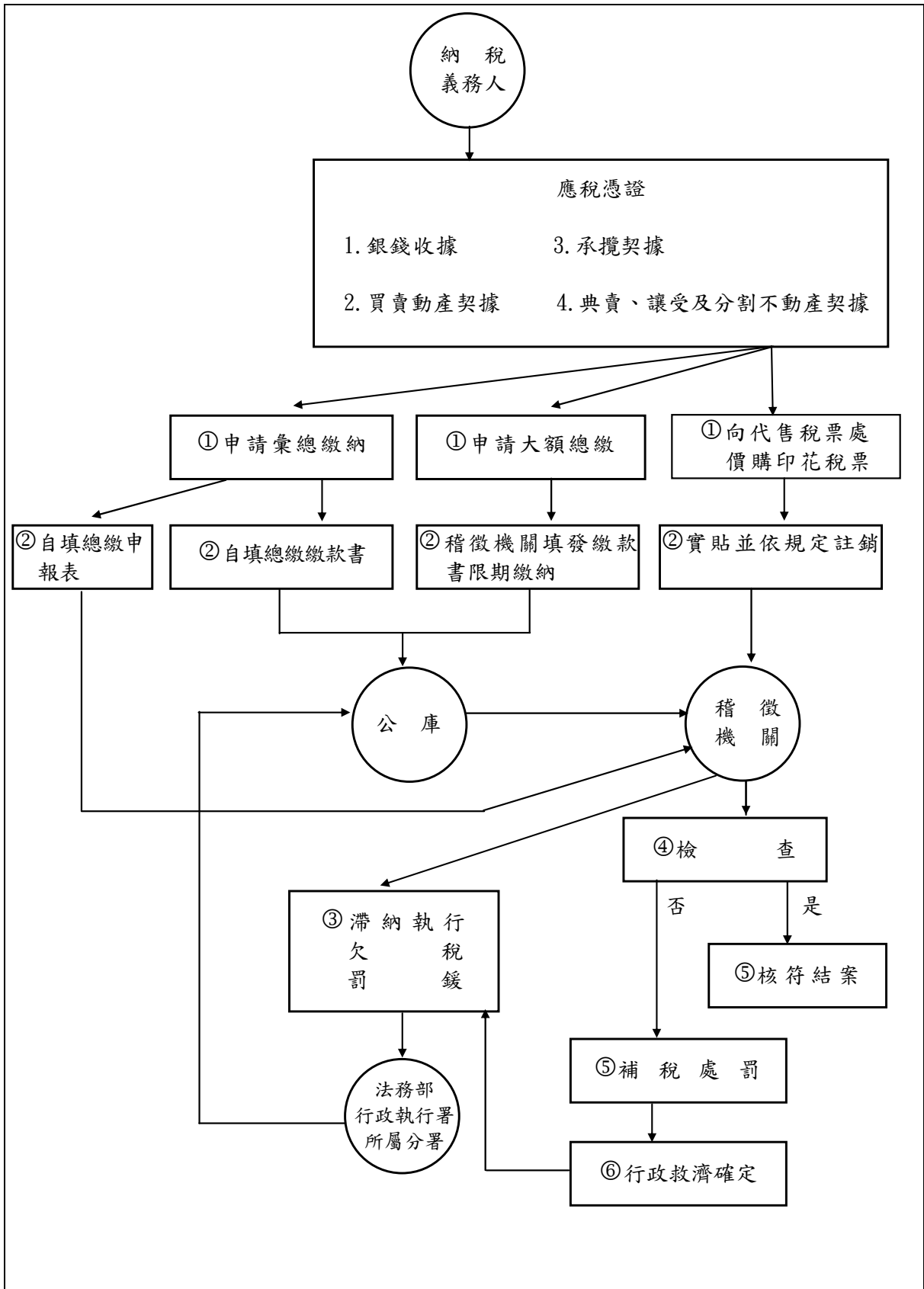

肆、行政組織

IV . Administrative Organization

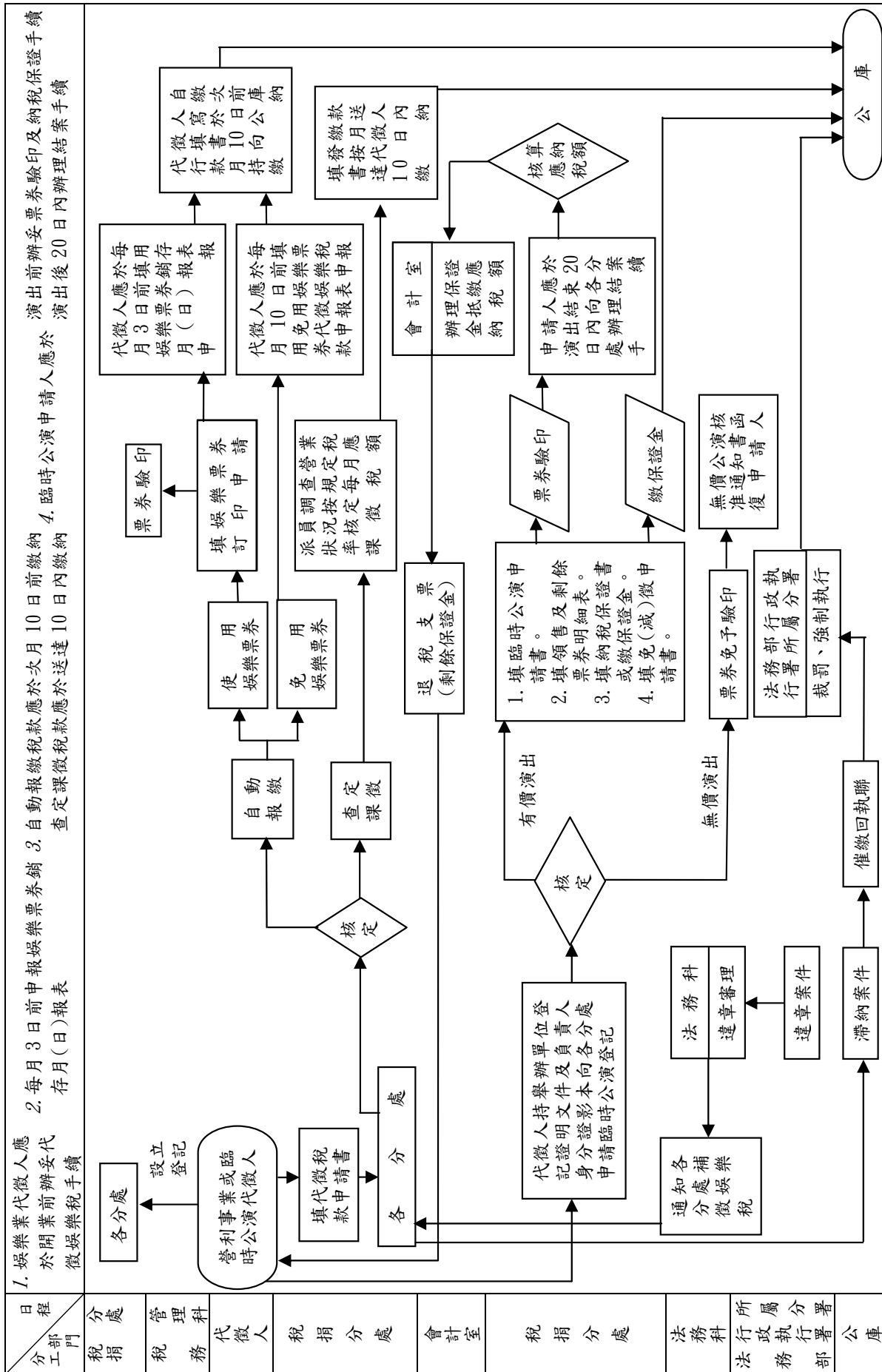
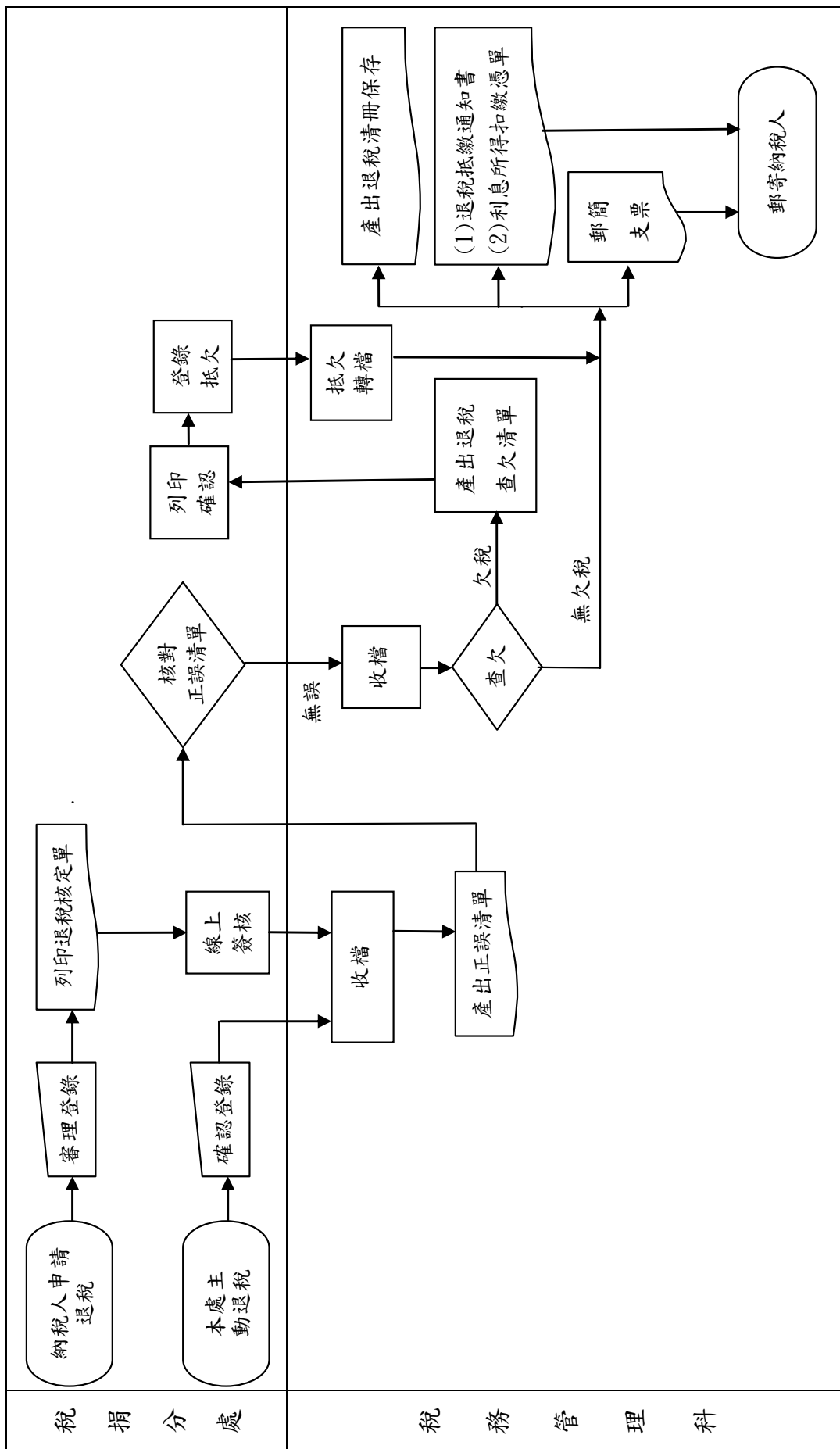
一、沿革

民國 34 年全省實施統一稽徵制度，臺北市設第一、第二稅務稽徵所管轄本市稅捐稽徵業務，民國 36 年 1 月合併成立臺北市稅捐稽徵處，下設 6 課及城中、中山、延平、萬華、古亭、松山等分處，掌理國、省、地方稅捐稽徵事宜，在系統上隸屬於臺北市政府而受臺灣省政府財政廳指揮監督。

民國 56 年 7 月臺北市改制為直轄市，財政部同時成立臺北市國稅局（102 年更名為財政部臺北國稅局）負責國稅之徵收，本處負責直轄市稅捐稽徵，並同時增設建成分處。民國 57 年 7 月，將市郊景美、木柵、南港、內湖及陽明山管理局之士林、北投等 6 鄉鎮正式劃入為臺北市管轄，除士林、北投另成立為陽明山管理局稅捐稽徵處外，景美、木柵 2 區成立景美分處，南港、內湖 2 區成立南港分處，隸屬於本處。民國 60 年 7 月，因大安區發展迅速，為加強便民服務，由古亭分處撥出成立大安分處。民國 63 年 1 月，原陽明山管理局稅捐稽徵處改隸本處，改設為士林分處。民國 75 年 1 月建成分處併入延平分處，士林分處劃出成立北投分處。民國 77 年 6 月增設內湖及大同 2 個分處。

民國 80 年 7 月，配合臺北市行政區調整為 12 區，本處按行政區域及業務情況設置 13 個分處，分別為中正（城中、古亭合併）、中北、中南（中山分出）、北投、萬華、信義（松山分出）、大安、松山、南港、文山（景美更名）、士林、內湖、大同（延平併入）等分處，就近為市民提供最便捷的納稅服務。

民國 88 年營業稅改制為國稅，仍由本處代徵，10 月為落實組織精簡，提升組織效能，實施組織重整並彈性調整各分處內部架構，業務量較大之大安、中南、中北、松山 4 個分處改設 5 個股，業務量較小之北投、內湖、南港、文山 4 個分處改設 3 個股，其餘大同、中正、信義、萬華、士林等 5 分處仍設 4 個股，並將娛樂稅、印花稅稽徵業務改由分處辦理。

民國 92 年 1 月營業稅移撥由財政部臺北市國稅局稽徵。本處負責房屋稅、地價稅、土地增值稅、契稅、使用牌照稅、娛樂稅、印花稅等地方稅及工程受益費之稽徵。同時重新訂定組織架構，將總處調整為 5 科 5 室，分處仍維持不變，除大安分處設置 4 個股外，其餘分處設置 3 個股。為因應業務需要增設第 2 位副處長職位，於 94 年 1 月正式派任。

民國 95 年 1 月為擴增服務據點，使用牌照稅業務比照其他稅目，將稽徵作業之執行改由分處辦理，人員配合移撥分處。松山分處因牌照稅業務量及員額配置較多，專設 1 股辦理該項業務，改置為 4 個股，至民國 100 年 9 月為配合使用牌照稅稽徵業務回歸機會稅科管理，復調整為 3 個股。民國 104 年士林分處因業務量及員額配置增加，改置 4 個股。民國 105 年 12 月 12 日配合南門市場改建工程，中正分處遷移至總處。

臺北市稅捐稽徵處暨所屬各分處稽徵區域圖

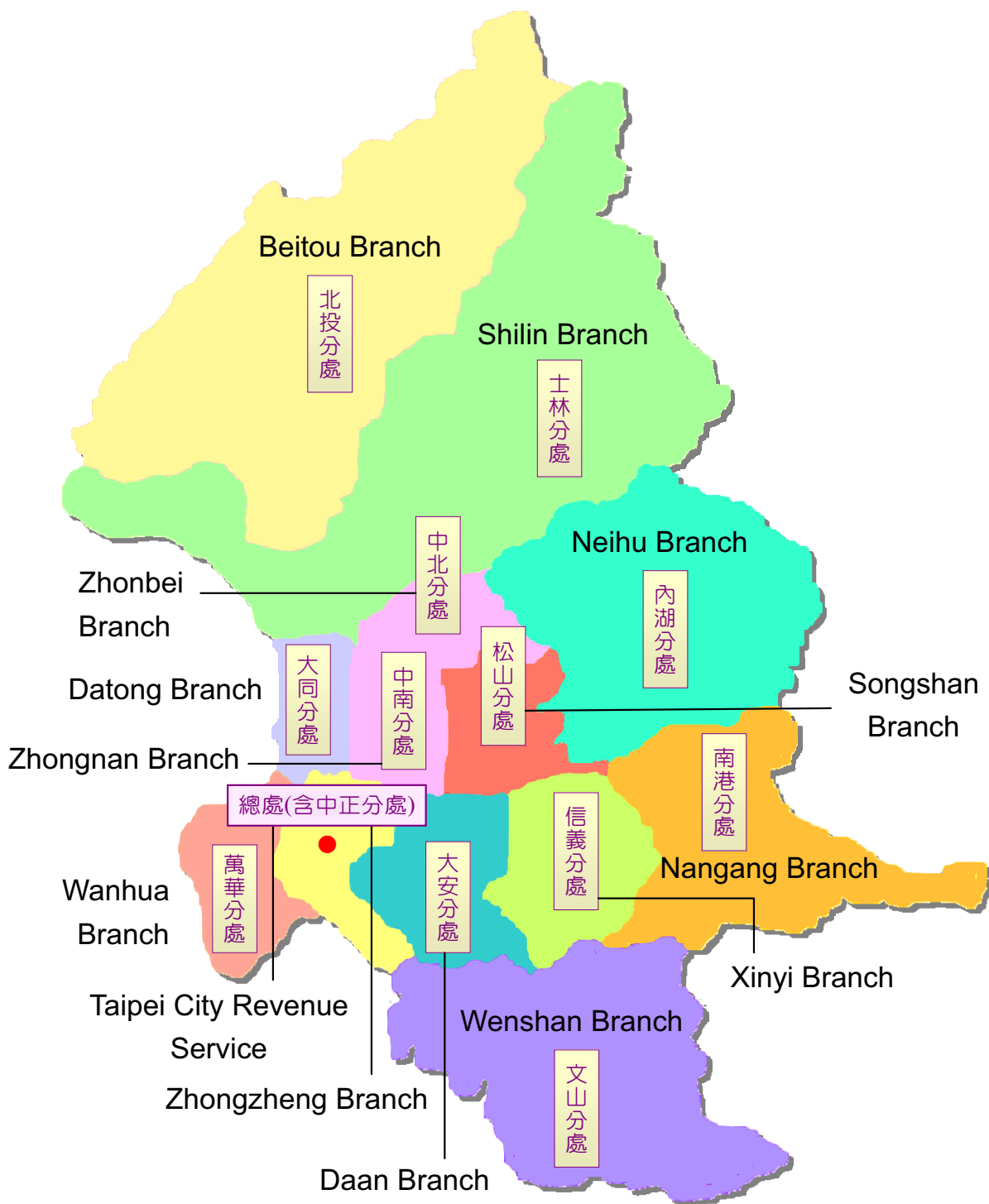

二、組織

本處組織：

依據臺北市政府 93 年 7 月 30 日府法三字第 09312725300 號令核定「臺北市稅捐稽徵處組織規程」，本處隸屬於臺北市政府財政局，置處長 1 人，綜理處務，並置副處長 2 人襄理處務，下設 5 科 5 室及 13 個分處掌理各項地方稅捐稽徵業務。

臺北市稅捐稽徵處組織圖

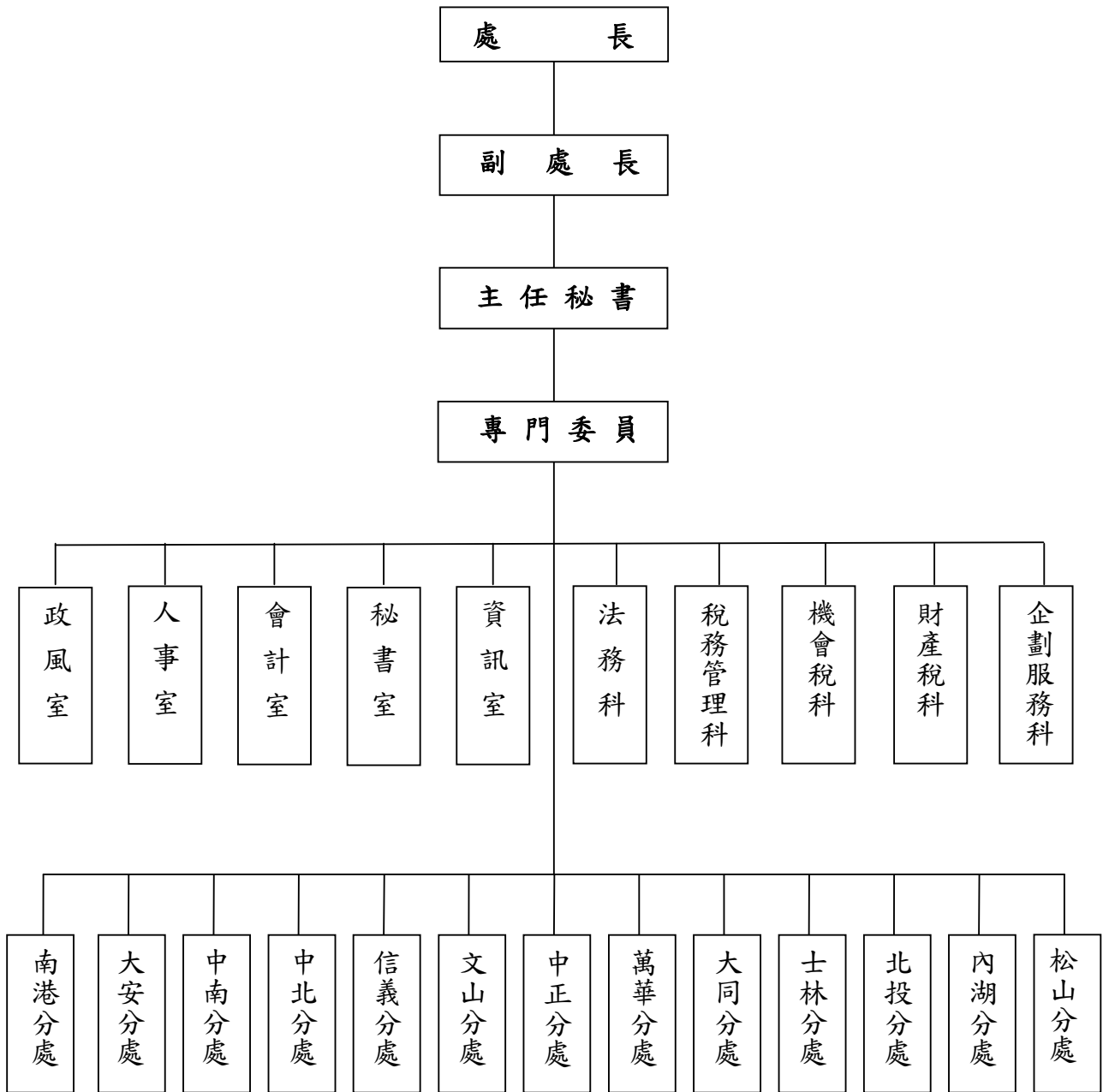

三、人事

本處編制員額 846 人，民國 106 年 12 月底現有職員 731 人。現有人員按學歷別分析，研究所畢業者 78 人占 10.7%，大專畢業者 615 人占 84.1%，高中(職)畢業者 37 人占 5.1%，國中畢業者 1 人占 0.1%；按考試及格別來看，其中高等考試及格者 208 人占 28.5%，普通考試及格者 77 人占 10.5%，特種考試及格者 297 人占 40.6%，升等考試及格者 94 人占 12.9%，初等考試及格者 47 人占 6.4%，其他考試及格者 7 人占 1.0%，依其他法令進用者 1 人占 0.1%；按年齡別分，20 歲至 29 歲 95 人占 13.0%，30 歲至 39 歲 198 人占 27.1%，40 歲至 49 歲 199 人占 27.2%，50 歲至 59 歲 196 人占 26.8%，60 歲以上 43 人占 5.9%，平均年齡為 43.1 歲。

現職人員年齡別
106年12月底

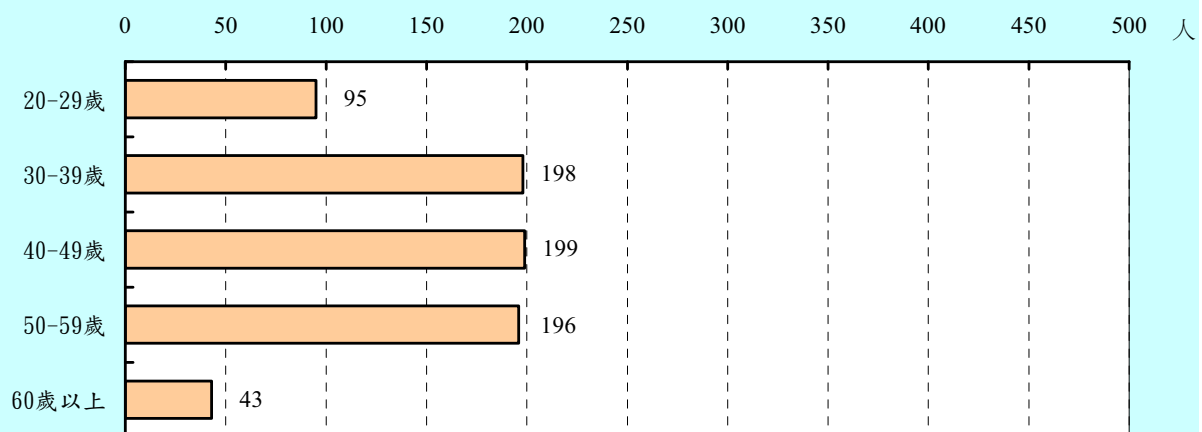

現職人員學歷別
106年12月底



表 19 本處人事概況
(一)法定員額與現有員額
106年12月底

單位：人

職 稱 Position	法定員額 Budget Staff		現有員額 Actual Staff	備 註	
	職 等	員 額			
總 計 Total		846	731	本表法定員額係奉 臺北市政府 93 年 7 月 30 日府法三字第 09312725300 號令核 定之員額。	
處 長 Director	第 十 一 職 等	1	1		
副 處 長 Deputy Director	第 十 職 等	2	2		
主 任 秘 書 Chief Secretary	第 九 職 等	1	1		
專 門 委 員 Senior Specialist	第 九 職 等	2	2		
科 長 Section Chief	第 八 職 等	5	5		
分 處 主 任 Manager, Branch	第 八 至 九 職 等	13	13		
主 任 Chief	第 八 職 等	2	2		
秘 書 Secretary	第 七 至 八 職 等	3	2		
督 導 Inspector	第 七 至 八 職 等	3	1		
審 核 員 Revenue Assessor	第 七 至 八 職 等	19	19		
專 員 Specialist	第 七 至 八 職 等	1	1		
股 長 Sub-section Chief	第 七 職 等	62	60		
分 析 師 Systems Analyst	第 七 職 等	2	2		
設 計 師 Systems Designer	第 五 或 六 至 七 職 等	14	14		
管 理 師 Systems Coordinator	第 五 或 六 至 七 職 等	4	4		
助 理 設 計 師 Assistant Systems Designer	第 三 至 五 職 等	6	2		
助 理 管 理 師 Assistant Systems Coordinator	第 三 至 五 職 等	1	1		
稅 務 員 Revenue Officer	第 五 或 六 至 七 職 等	344	323		
助 理 稅 務 員 Revenue Assistant	第 三 至 五 職 等	167	144		
科 員 Section Assistant	第 五 或 六 至 七 職 等	6	5		
辦 事 員 Senior Clerk	第 三 至 五 職 等	19	18		
書 記 Clerk	第 一 至 三 職 等	124	68		(內 2 人俟雇員出 缺後改置)

續下頁

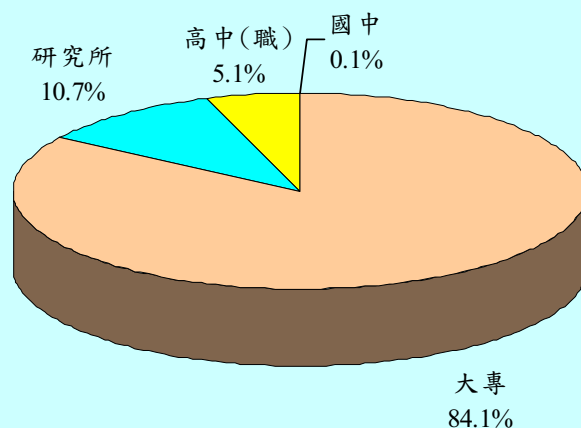
表 19 本處人事概況(續 1)

(一)法定員額與現有員額

106年12月底

單位：人

職 稱 Position	法定員額 Budget Staff		現有員額 Actual Staff	備 註	
	職 等	員 額			
會計室 Accounting office	會計主任 Chief Accounting Officer	第 八 職 等	1	1	
	專員 Specialist	第 七 至 八 職 等	1	1	
	股長 Sub- section Chief	第 七 職 等	4	4	
	科員 Section Assistant	第 五 或 六 至 七 職 等	11	11	
	辦事員 Senior Clerk	第 三 至 五 職 等	1	1	
	書記 Clerk	第 一 至 三 職 等	2	1	
	人 事 室 Personnel Office	主任 Chief Personnel Officer	第 八 職 等	1	1
專員 Specialist		第 七 至 八 職 等	1	1	
股長 Sub- section Chief		第 七 職 等	3	3	
科員 Section Assistant		第 五 或 六 至 七 職 等	8	7	
助理員 Assistant		第 四 至 五 職 等	2	2	(內 1 人得列 薦任)
書記 Clerk		第 一 至 三 職 等	1	—	
政 風 室 Government Ethics Office		主任 Chief Government Ethics Officer	第 八 職 等	1	1
	股長 Sub- section Chief	第 七 職 等	2	2	
	科員 Section Assistant	第 五 或 六 至 七 職 等	4	4	
	辦事員 Senior Clerk	第 三 至 五 職 等	1	1	
	書記 Clerk	第 一 至 三 職 等	1	—	

資料來源：依據本處人事室資料編製。

表 19 本處人事概況(續 2)

(二) 年齡與職等、性別

106 年 12 月底

單位：人

年 齡 age	官 等 Official Classes					性 別 Sex		
	共 計 Total	10-14 職等 Selected Appointment	6-9 職等 Recommended Appointment	1-5 職等 Delegated Appointment	雇 員 Assistant Clerk	共 計 Total	男 Male	女 Female
總 計 Grand Total	731	3	418	308	2	731	146	585
20 歲 - 29 歲	95	—	47	48	—	95	16	79
30 歲 - 39 歲	198	—	98	100	—	198	51	147
40 歲 - 49 歲	199	—	120	79	—	199	36	163
50 歲 - 59 歲	196	1	135	59	1	196	34	162
60 歲 以 上	43	2	18	22	1	43	9	34

(三) 學歷及考試

106 年 12 月底

單位：人

學 歷 及 考 試 別 Educational & Examination	共 計 Total	10-14 職等 Selected Appointment	6-9 職等 Recommended Appointment	1-5 職等 Delegated Appointment	雇 員 Assistant Clerk
(1) 學 歷 Education	731	3	418	308	2
研 究 所 Graduate School	78	1	58	19	—
大 專 Junior College	615	2	355	257	1
高 中 (職) Senior High School	37	—	5	31	1
國 (初) 中 及 以 下 Junior High School and Under	1	—	—	1	—
(2) 考 試 Examination	731	3	418	308	2
高 等 考 試 Senior Civil Service Exam.	208	1	195	12	—
普 通 考 試 Junior Civil Service Exam.	77	—	25	52	—
特 種 考 試 Special Civil Service Exam.	297	1	126	170	—
升 等 考 試 Rank Promotion Service Exam.	94	1	64	29	—
初 等 考 試 Elementary Civil Service Exam.	47	—	6	41	—
其 他 考 試 Other Civil Service Exam.	7	—	2	3	2
依 其 他 法 令 進 用 By Other Means	1	—	—	1	—

表 19 本處人事概況(續 3 完)

(四)年 資

106 年 12 月底

單位：人

年 資 Seniority	共 計 Total	10—14 職等 Selected Appointment	6—9 職等 Recommended Appointment	1—5 職等 Delegated Appointment	雇 員 Assistant Clerk
總 計 Grand Total	731	3	418	308	2
5 年 以 下	257	—	123	134	—
6 年— 9 年	98	—	43	55	—
10 年—14 年	65	—	30	35	—
15 年—19 年	66	—	42	24	—
20 年—24 年	151	—	102	47	2
25 年—29 年	50	1	40	9	—
30 年 以 上	44	2	38	4	—

(五)工 作 類 別

106 年 12 月底

單位：人

工 作 類 別 Job	共 計 Total	10—14 職等 Selected Appointment	6—9 職等 Recommended Appointment	1—5 職等 Delegated Appointment	雇 員 Assistant Clerk
總 計 Grand Total	731	3	418	308	2
行 政	66	—	9	57	—
財 政	595	3	362	230	—
人 事	14	—	10	4	—
會 計	19	—	15	4	—
雇 員	2	—	—	—	2
資 訊 處 理	27	—	16	11	—
政 風	8	—	6	2	—
安 全 保 防	—	—	—	—	—

表 20 本處歲出預決算數

單位：新臺幣元

年度及科目別	預 算		決 算		決算數 占預算數 之比率 % (2/1)×100
	金 額 (1)	%	金 額 (2)	%	
97 年 度	923,887,755	100.0	895,044,198	100.0	96.9
98 年 度	925,665,198	100.0	898,324,537	100.0	97.0
99 年 度	910,138,102	100.0	898,108,142	100.0	98.7
100 年 度	924,158,185	100.0	915,283,662	100.0	99.0
101 年 度	926,239,026	100.0	898,931,066	100.0	97.1
102 年 度	937,691,092	100.0	916,073,419	100.0	97.7
103 年 度	928,468,874	100.0	918,028,505	100.0	98.9
104 年 度	974,283,556	100.0	949,010,297	100.0	97.4
105 年 度	924,717,371	100.0	910,775,252	100.0	98.5
106 年 度	923,301,505	100.0	909,997,555	100.0	98.6
一般行政	169,900,316	18.4	166,206,651	18.3	97.8
行政管理	169,900,316	18.4	166,206,651	18.3	97.8
稅捐稽徵業務	739,078,743	80.0	731,599,781	80.4	99.0
財產稅稽徵	366,574,266	39.7	365,892,888	40.2	99.8
機會稅稽徵	65,530,039	7.1	61,087,763	6.7	93.2
稅務管理	217,651,431	23.6	215,885,887	23.7	99.2
違章及行政救濟	16,215,442	1.8	15,855,979	1.7	97.8
電子處理資料	73,107,565	7.9	72,877,264	8.0	99.7
建築及設備	14,322,446	1.6	12,191,123	1.3	85.1
土地購置	100,000	0.0	—	--	--
營建工程	11,155,307	1.2	9,257,707	1.0	83.0
交通及運輸設備	95,000	0.0	95,000	0.0	100.0
其他設備	2,972,139	0.3	2,838,416	0.3	95.5

資料來源：依據審計部臺北市審計處審核決算審定書編製。

附註：1. 本表未包括統籌科目。

2. 106年度決算數尚未經審計部臺北市審計處審定。

中華民國 106 年度
臺北市稅捐統計年報

出版機關：臺北市稅捐稽徵處

發行人：蘇鈞堅

編輯：臺北市稅捐稽徵處會計室

地址：臺北市中正區北平東路 7 之 2 號

電話：(02)23949211 分機 341

網址：www.tpctax.gov.taipei

創刊日期：中華民國 42 年 2 月

出版日期：中華民國 107 年 3 月

出刊頻率：年刊

本刊登載於本處網站

依法納稅是義務

合法節稅是權利

主動退稅是責任

