

中華民國110年度
臺北市稅捐統計年報

YEARBOOK OF MUNICIPAL TAX
STATISTICS OF TAIPEI CITY
2021



臺北市稅捐稽徵處
TAIPEI CITY REVENUE SERVICE
111年5月編製

編 製 說 明

- 一、本刊之編製，旨在提供本處稽徵業務執行與成果資料，以為公務計畫、執行、考核及財務管理上之參考。
- 二、本刊資料內容包括提要分析、稅收、稅源及其他、行政組織等 4 大項。
- 三、本刊所稱「年度」係指政府會計年度，採曆年制(當年 1 月 1 日至同年 12 月 31 日)。
- 四、本刊數字因尾數四捨五入，故部分總數與細項之間，或有未能吻合情事，計算時仍以原始數據計算。
- 五、本刊所有符號「—」表示無數值，「--」表示無意義數值，「…」表示數值不明或尚未產生資料，「0」表示有數值而不及半單位，數字前加(-)者表示退稅或減免數，(+)者表示增加數，「(r)」表示修正數。
- 六、本刊自 110 年度版起，依據財政部統計處 110 年 12 月 14 日財統發字第 11011916310 號函「地方稅統計年報一致化格式參考範本」編製，本刊資料如與前期刊物有出入者，以本刊所列數字為準。

目 次

壹、提要分析

一、110 年度稅收概況	2
二、近 10 年稅收	3
三、地價稅	4
四、土地增值稅	5
五、房屋稅	6
六、使用牌照稅	7
七、契稅	8
八、印花稅	9
九、娛樂稅	10

貳、稅收

表 2-1 各項稅捐預算數、查定數與實徵數	12
總計	12
一、稅捐收入	14
(一)地價稅	16
(二)土地增值稅	18
(三)房屋稅	20
(四)使用牌照稅	22
(五)契稅	24
(六)印花稅	26
(七)娛樂稅	28
(八)教育捐	30
二、罰鍰收入	32
(一)財務罰鍰	34
(二)罰金罰鍰	36
表 2-2 各項稅捐實徵淨額與結構比	38
表 2-3 各項稅捐繳付公庫數	42
總計	42
一、本年度	44
二、以前年度	46
三、收回以前年度繳付數	48
表 2-4 各項稅捐徵績比較	50

CONTENTS

I. Summary Analysis

A. Tax Revenues in 2021	2
B. Tax Revenues in Nearly 10 Years	3
C. Land Value Tax	4
D. Land Value Increment Tax	5
E. House Tax	6
F. Vehicle License Tax	7
G. Deed Tax	8
H. Stamp Tax	9
I. Amusement Tax	10

II. Tax Revenues

Table 2-1 Budget Amount, Audited Amount and Actual Collection	12
Grand Total	12
A. Collections of Taxes and Surtaxes	14
1. Land Value Tax	16
2. Land Value Increment Tax	18
3. House Tax	20
4. Vehicle License Tax	22
5. Deed Tax	24
6. Stamp Tax	26
7. Amusement Tax	28
8. Education Surtax	30
B. Punitive Fine Revenue	32
1. Financial Penalty	34
2. Belated Surcharge	36
Table 2-2 Net Actual Collection and Structure Ratio in Recent Year	38
Table 2-3 Taxation Forwarded to Treasury	42
Grand Total	42
A. Current Fiscal Year	44
B. Previous Fiscal Year	46
C. Tax Refund for Previous Year	48
Table 2-4 Net Tax Revenues Compare	50

參、稅源及其他

表 3-1 地價稅稅源	54
一、稅地種類分析	54
二、減免稅地概況	56
表 3-2 土地增值稅稅源	58
一、按稅率別分	58
二、按移轉原因別分	60
表 3-3 房屋稅稅源	64
表 3-4 使用牌照稅稅源及稽徵	80
一、稅源	80
二、稽徵	82
表 3-5 契稅稅源	84
表 3-6 印花稅稅源	88
表 3-7 娛樂稅稅源	92
表 3-8 各項稅捐劃解百分率一覽表	96
表 3-9 各項稅捐現行稅率	98
表 3-10 查(核)定開徵數、未徵數情形	108
總計	108
一、本年度	114
二、以前年度	120
表 3-11 違章漏稅案件處理及財務罰鍰執行情形	126
表 3-12 各項稅捐稽徵成本統計	130
表 3-13 各項稅捐滯納案件移送執行情形	132
表 3-14 各項稅捐稽徵工作流程	134

肆、行政組織

沿革	144
表 4-1 組織概況	148
表 4-2 現有員額配置	150
表 4-3 現有人員人事資料統計	154
表 4-4 歲出預決算數	156

III. Tax Sources and Others

- Table 3-1 Sources of Land Value Tax 54
 - A. Analysis for the Kinds of Land 54
 - B. Broadview for the Reduction or Exemption of Land 56
- Table 3-2 Sources of Land Value Increment Tax 58
 - A. By Tax Rate 58
 - B. By Transfer Reason 60
- Table 3-3 Sources of House Tax 64
- Table 3-4 Sources of Levy of Vehicle License Tax 80
 - A. Sources of Vehicle License Tax 80
 - B. Levy of Vehicle License Tax 82
- Table 3-5 Sources of Deed Tax 84
- Table 3-6 Sources of Stamp Tax 88
- Table 3-7 Sources of Amusement Tax 92
- Table 3-8 The Distribution Rate of Current Taxes 96
- Table 3-9 Current Tax Rates for Taxation 98
- Table 3-10 The Management of Opening Collection for
 - Assessed(Verified) and of Tax Not Collected 108
 - Grand Total 108
 - A. Current Fiscal Year 114
 - B. Previous Fiscal Years 120
- Table 3-11 The Management of Tax Evasion Law and
 - Execution Status of Fine 126
- Table 3-12 Cost of Tax Levying 130
- Table 3-13 The status of Delayed Case Transferred to Execution 132
- Table 3-14 Work Flow Chart 134

IV. Administrative Organization

- The History 144
- Table 4-1 Organization of Headquarter and Branches 148
- Table 4-2 Allocation of the Personnel 150
- Table 4-3 Personnel Statistics 154
- Table 4-4 The Budget and Final Accounts of Annual Expenditure 156

壹、提要分析

I. Summary Anzlysis

一、110 年度稅收概況

110 年度本市地方稅稅收實徵淨額 766.86 億元，較預算數 734.60 億元，超出 32.26 億元，年度預算達成率 104.4%，各項稅收與預算數比較，除地價稅、娛樂稅因嚴重特殊傳染性肺炎影響，申請延分期、娛樂性消費減少，以及使用牌照稅因大批催繳作業延後辦理和部分納稅義務人延後繳納，致稅收較預算數短少外，其餘各稅皆較預算數超出，其中以土地增值稅較預算數超出 24.24 億元最多，主要係 110 年度有多筆大額稅款繳納所致，其次為印花稅較預算數超出 6.25 億元，餘依序為契稅及房屋稅，其實徵淨額分別較預算數超出 4.20 億元及 3.87 億元。(詳表 1、圖 1)

表 1 110 年度地方稅稅課收入

單位：新臺幣億元

稅目別	預算數 (1)	實徵淨額 (2)	較預算數超出(或短少)		預算達成率(%) (5)=(2)/(1)*100
			金額 (3)=(2)-(1)	百分比(%) (4)=(3)/(1)*100	
稅 課 收 入	734.60	766.86	32.26	4.4	104.4
地 價 稅	275.26	271.40	-3.86	-1.4	98.6
土 地 增 值 稅	164.00	188.24	24.24	14.8	114.8
房 屋 稅	154.00	157.87	3.87	2.5	102.5
使 用 牌 照 稅	74.50	73.90	-0.60	-0.8	99.2
契 稅	15.69	19.89	4.20	26.8	126.8
印 花 稅	48.70	54.95	6.25	12.8	112.8
娛 樂 稅	2.45	0.61	-1.84	-75.1	24.9

圖 1 110 年度稅收實徵淨額各稅比重

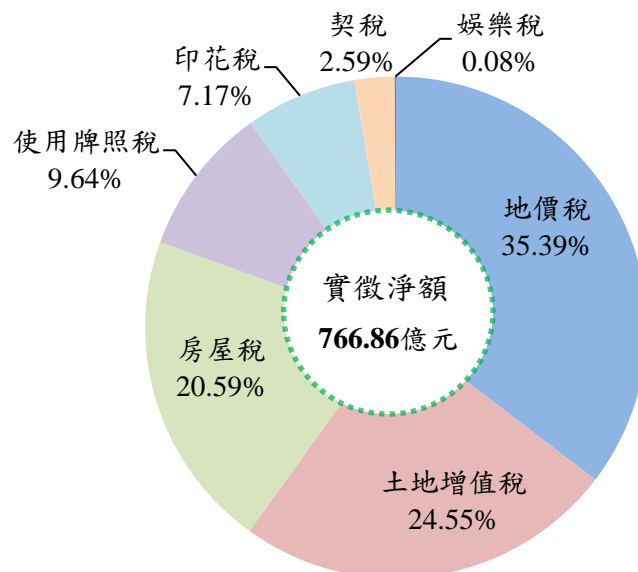

二、近 10 年稅收

近 10 年本市地方稅稅收實徵淨額大致呈現上升趨勢，109 至 110 年雖有嚴重特殊傳染性肺炎疫情，仍維持正成長。此外，僅 106 年度及 107 年度稅收較預算數短少，其餘均較預算數超出。106 年度稅收較預算數短少主要係因本市土地公告現值平均調降，107 年度則係因本市土地公告現值及公告地價平均調降。另 104 年度為近 10 年稅收超出預算數最多，主要係因 104 年調漲土地公告現值及 105 年 1 月 1 日起實施房地合一課徵所得稅制度影響，有多筆大面積土地移轉。(詳表 2、圖 2)

表 2 近 10 年稅課收入

單位：新臺幣億元

年度別	預算數	實徵淨額	實徵淨額較預算數 超出(或短少)		實徵淨額較上年度 增減比較	
			金額	百分比(%)	金額	百分比(%)
101	610.50	621.89	11.39	1.9	1.90	0.3
102	604.30	663.11	58.81	9.7	41.22	6.6
103	630.75	672.91	42.16	6.7	9.80	1.5
104	650.75	768.23	117.48	18.1	95.32	14.2
105	715.47	753.22	37.75	5.3	-15.01	-2.0
106	750.14	748.89	-1.25	-0.2	-4.33	-0.6
107	752.20	718.15	-34.05	-4.5	-30.74	-4.1
108	726.17	746.41	20.24	2.8	28.26	3.9
109	733.31	757.51	24.20	3.3	11.10	1.5
110	734.60	766.86	32.26	4.4	9.35	1.2

圖 2 近 10 年稅課收入預算數與實徵淨額

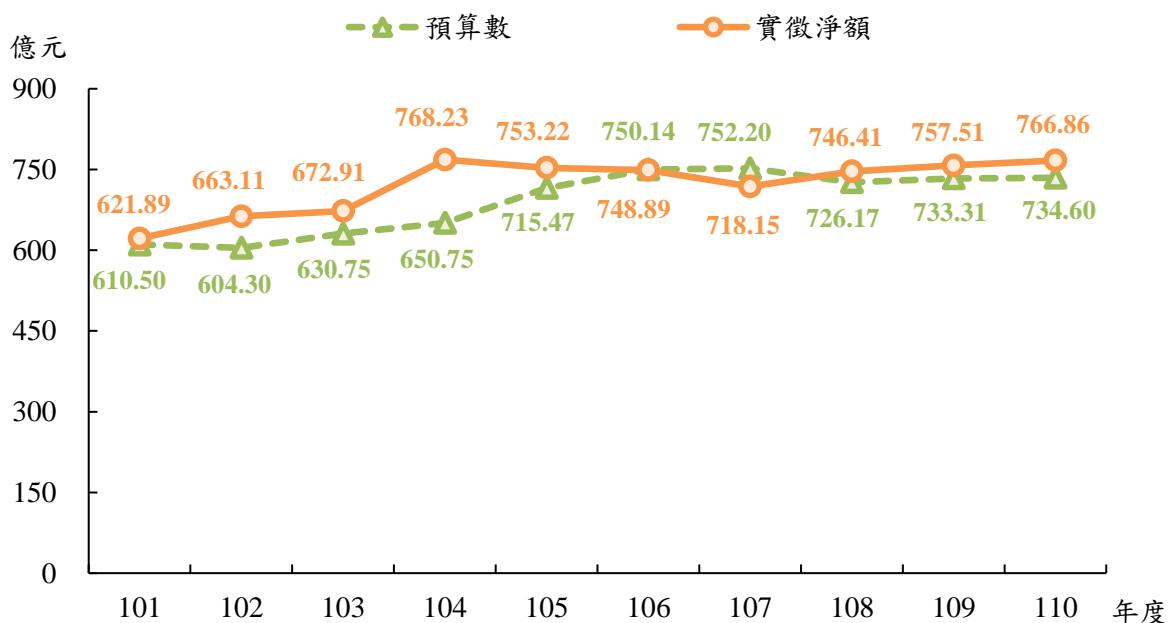

三、地價稅

110 年度實徵淨額 271.40 億元，較預算數 275.26 億元短少 3.86 億元(-1.4%)；與上年度實徵淨額 278.43 億元比較，減少 7.03 億元，負成長 2.5%。110 年度因受嚴重特殊傳染性肺炎影響，申請延分期繳納稅款，致稅收較預算數短少且較上年度減少。(詳圖 3)

地價稅稅源若以課稅面積觀察，以一般土地 2,624.65 公頃，占 52.25%最多，其次為自用住宅用地 2,165.82 公頃，占 43.12%，其餘依次為公共設施保留地占 2.40%，其他等用地占 2.23%。(詳圖 4)

圖 3 近 10 年地價稅預算數與實徵淨額



圖 4 110 年度地價稅稅源



四、土地增值稅

110 年度實徵淨額 188.24 億元，較預算數 164.00 億元超出 24.24 億元(14.8%)；與上年度實徵淨額 180.71 億元比較，增加 7.53 億元，成長 4.2%。因 110 年度有多筆大額稅款繳納，致稅收較預算數超出且較上年度增加。(詳圖 5)

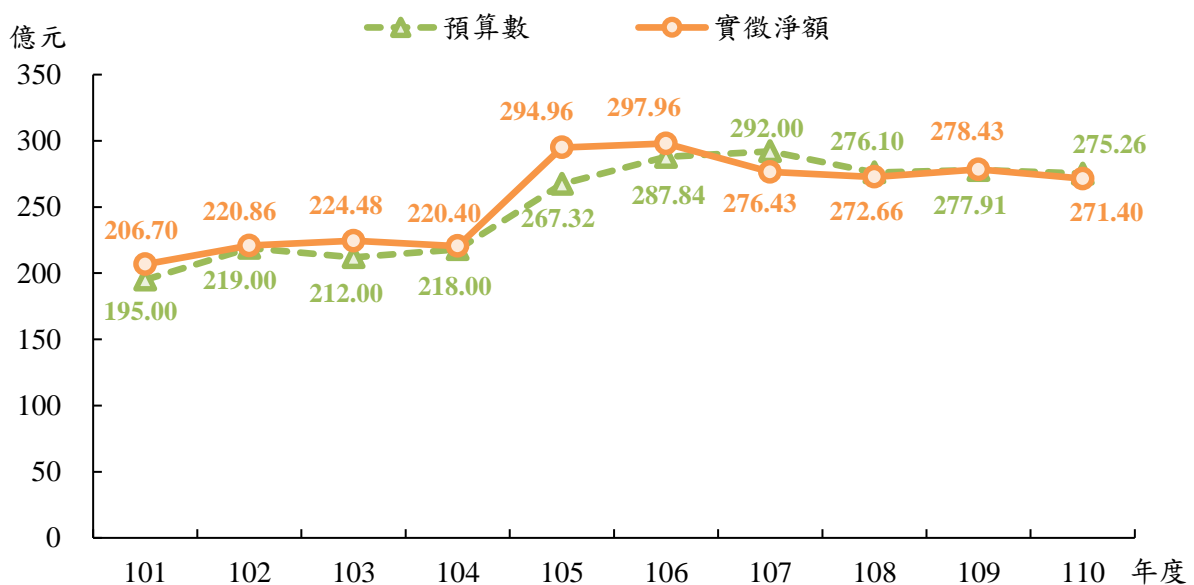
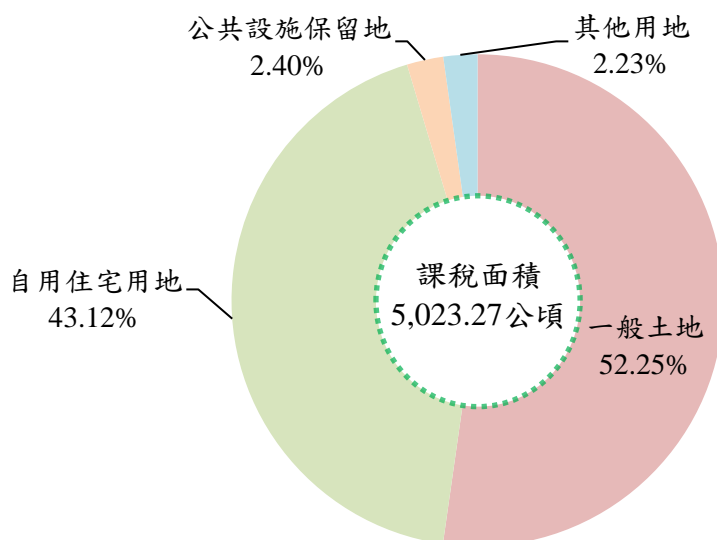
土地增值稅稅源若以稅率別的課稅面積觀察，以免稅地 142 萬 9,449 平方公尺，占 60.67%最多，其餘依序為一般用地 70 萬 2,267 平方公尺，占 29.80%，自用住宅用地則為 22 萬 4,499 平方公尺，占 9.53%。(詳圖 6)

圖 5 近 10 年土地增值稅預算數與實徵淨額



圖 6 110 年度土地增值稅稅源-稅率別



五、房屋稅

110 年度實徵淨額 157.87 億元，較預算數 154.00 億元增加 3.87 億元 (2.5%)；與上年度實徵淨額 150.90 億元比較，增加 6.97 億元，成長 4.6%。110 年度主要係因 109 年度因嚴重特殊傳染性肺炎影響核准延分期案於本年度繳納，以及加強房屋稅籍與使用情形清查，致稅收較預算數超出且較上年度增加。(詳圖 7)

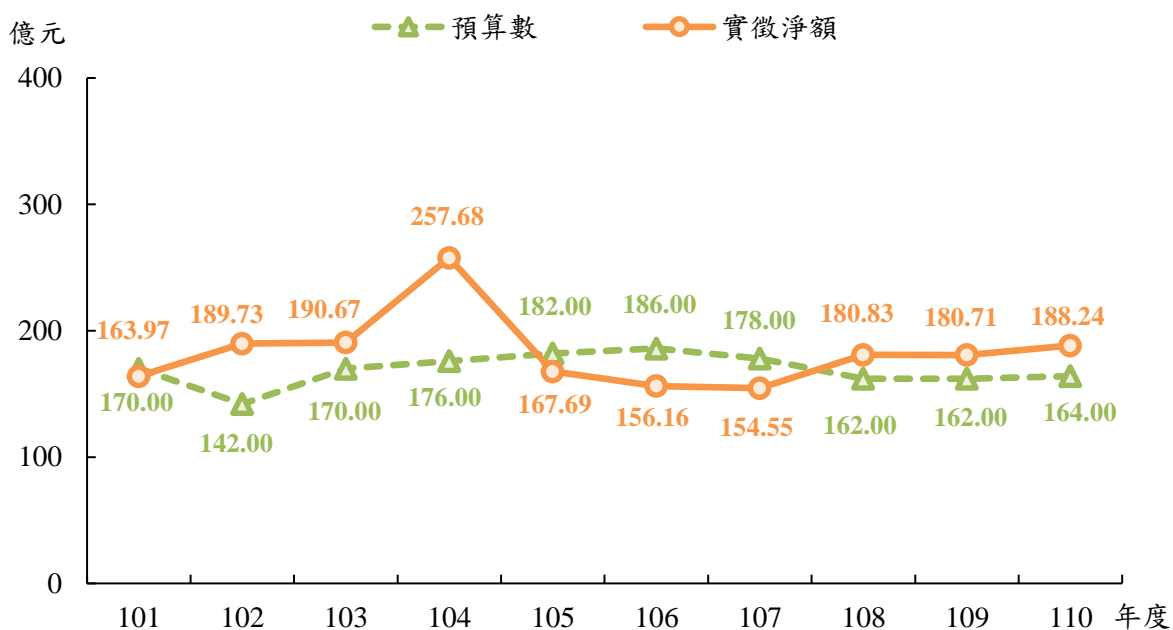
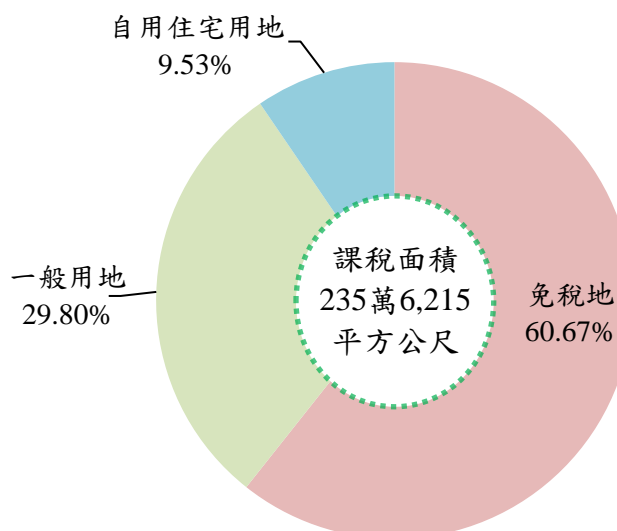
房屋稅稅源若以房屋構造別的課稅面積觀察，以鋼筋混凝土及預鑄造計 1 億 6,051 萬平方公尺最多，占 77.11%，其次為鋼骨造、鋼骨混凝土造及鋼骨鋼筋混凝土造計 2,989 萬平方公尺，占 14.36%，再次為加強磚造 1,265 萬平方公尺，占 6.08%。(詳圖 8)

圖 7 近 10 年房屋稅預算數與實徵淨額



圖 8 110 年度房屋稅稅源-構造別



六、使用牌照稅

110 年度實徵淨額 73.90 億元，較預算數 74.50 億元短少 0.60 億元(-0.8%)；與上年度實徵淨額 74.33 億元比較，減少 0.43 億元，負成長 0.6%。110 年度因受疫情影響，使用牌照稅大批催繳作業延後辦理，部分納稅義務人延後繳納，致稅收較預算數短少。(詳圖 9)

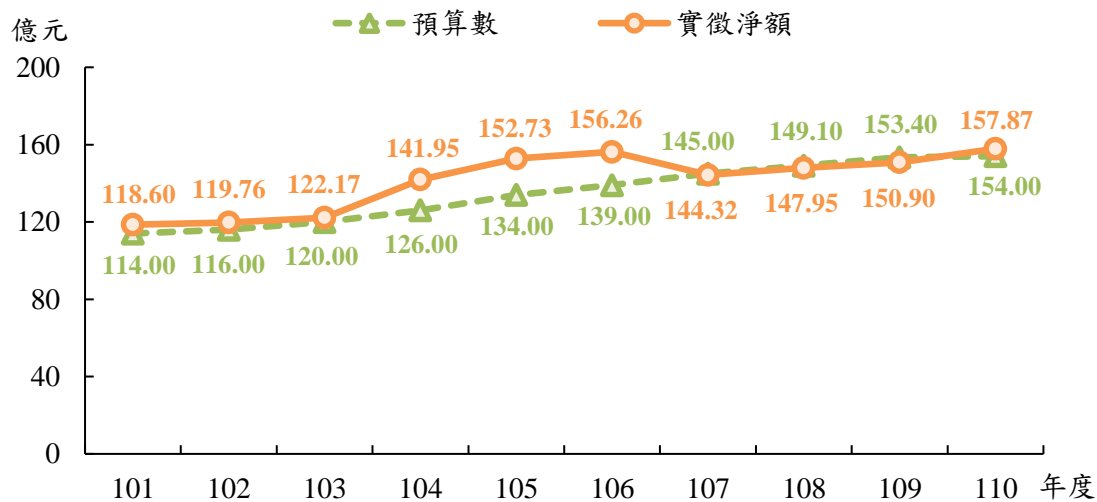
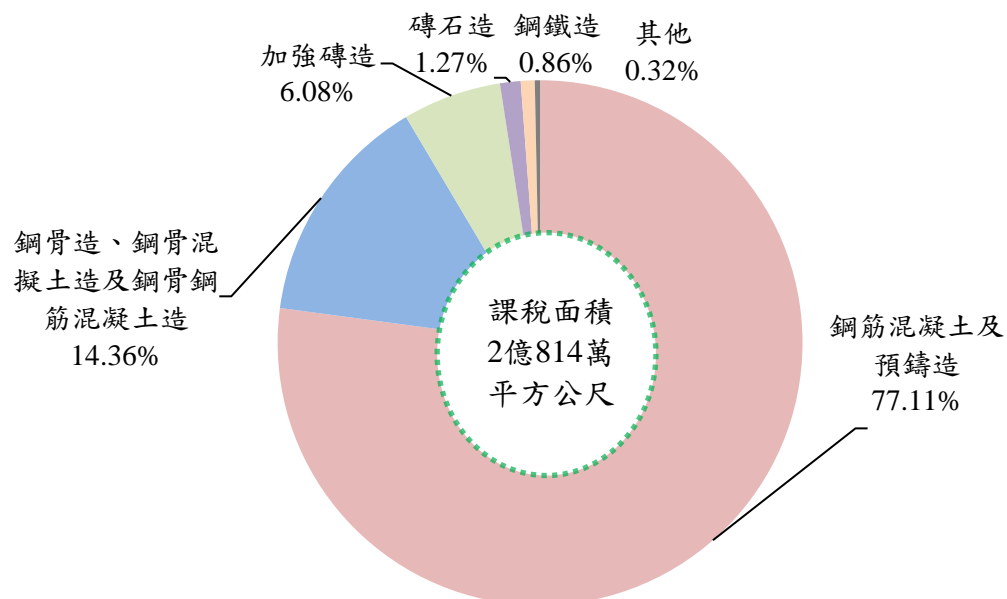
使用牌照稅稅源若以一般車輛件數觀察，以小客車 79 萬 8,536 件最多，占 81.99%，其次為貨車 10 萬 5,470 件，占 10.83%，其餘依序為機車占 6.42%，大客車占 0.77%。(詳圖 10)

圖 9 近 10 年使用牌照稅預算數與實徵淨額



圖 10 110 年度使用牌照稅稅源



七、契稅

110 年度實徵淨額 19.89 億元，較預算數 15.69 億元超出 4.2 億元(26.8%)；與上年度實徵淨額 18.93 億元比較，增加 0.96 億元，成長 5.1%。110 年度因契稅申報移轉大額稅款件數較多，致稅收較預算數超出且較上年度增加。(詳圖 11)

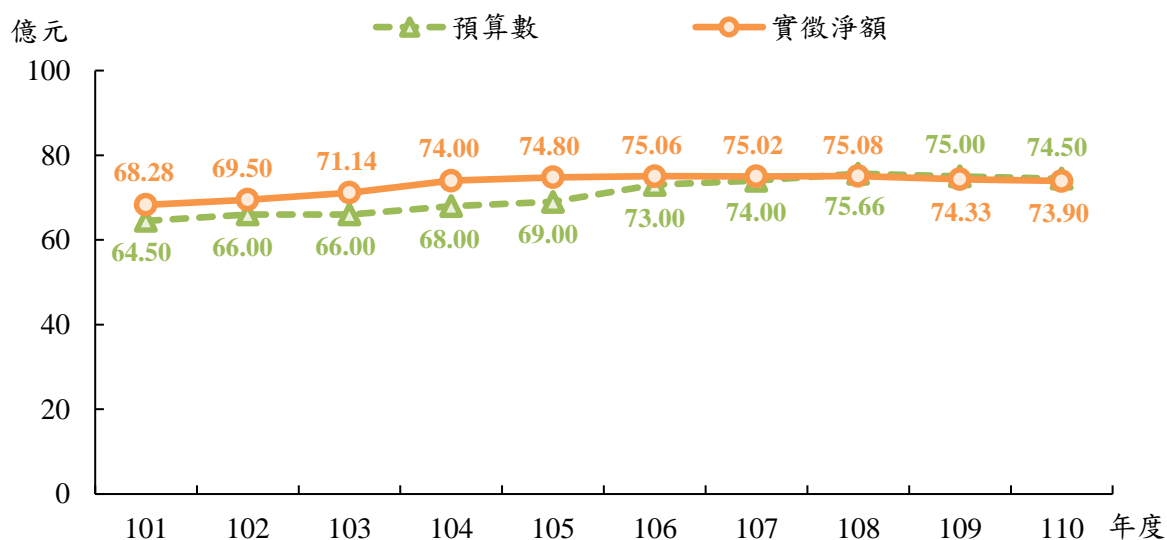
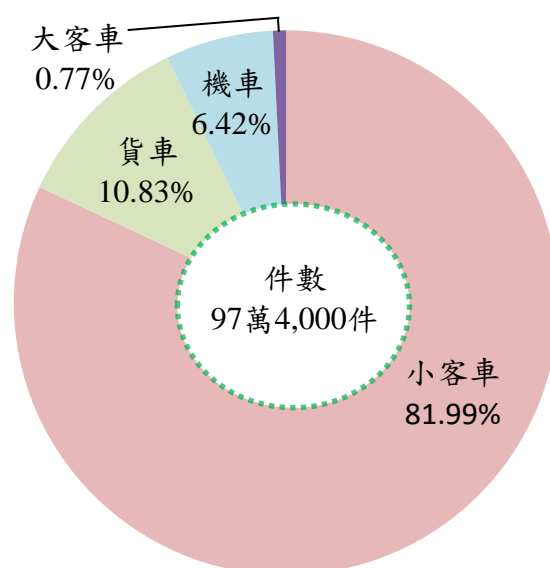
契稅稅源若以件數觀察，以買賣契 3 萬 3,757 件最多，占 80.29%，其次為贈與契 7,195 件，占 17.12%，再次為交換契 1,037 件，占 2.47%。(詳圖 12)

圖 11 近 10 年契稅預算數與實徵淨額



圖 12 110 年度契稅稅源



八、印花稅

110 年度實徵淨額 54.95 億元，較預算數 48.70 億元超出 6.25 億元(12.8%)；與上
年度實徵淨額 52.72 億元比較，增加 2.23 億元，成長 4.2%。110 年度因印花稅大額
總繳承攬案件增加，致稅收較預算數超出且較上年度增加。(詳圖 13)

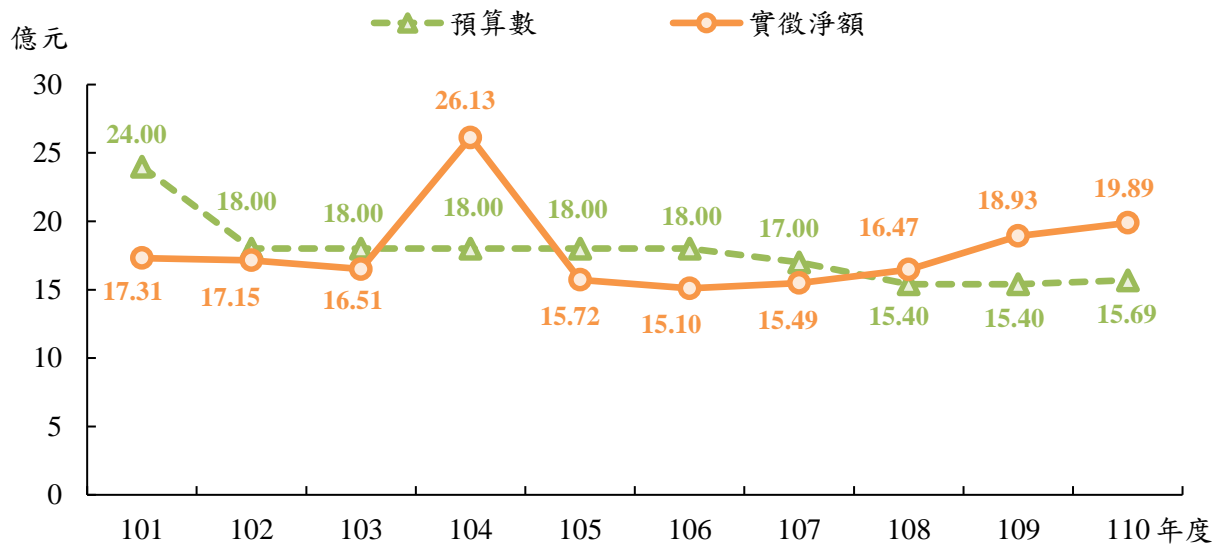
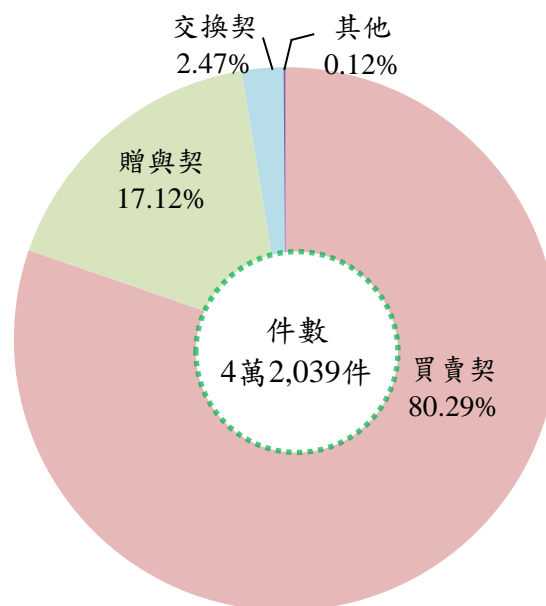
印花稅稅源實徵數以金融業 15.24 億元最多，占 27.73%，其次為保險業 9.96
億元，占 18.11%，再次為承攬契據 9.19 億元，占 16.71%。(詳圖 14)

圖 13 近 10 年印花稅預算數與實徵淨額



圖 14 110 年度印花稅稅源



九、娛樂稅

110 年度實徵淨額 0.61 億元，較預算數 2.45 億元短少 1.84 億元(- 75.1%)；與上年度實徵淨額 1.49 億元比較，減少 0.88 億元，負成長 59.1%。110 年度因嚴重特殊傳染性肺炎疫情對國內經濟、社會造成衝擊，自 110 年 5 月 15 日防疫警戒提升為三級，本市休閒娛樂場所及觀展觀賽場所等全面暫停營業，且本市自 109 年 12 月起娛樂稅徵收率減半課徵，致稅收較預算數短少且較上年度減少。(詳圖 15)

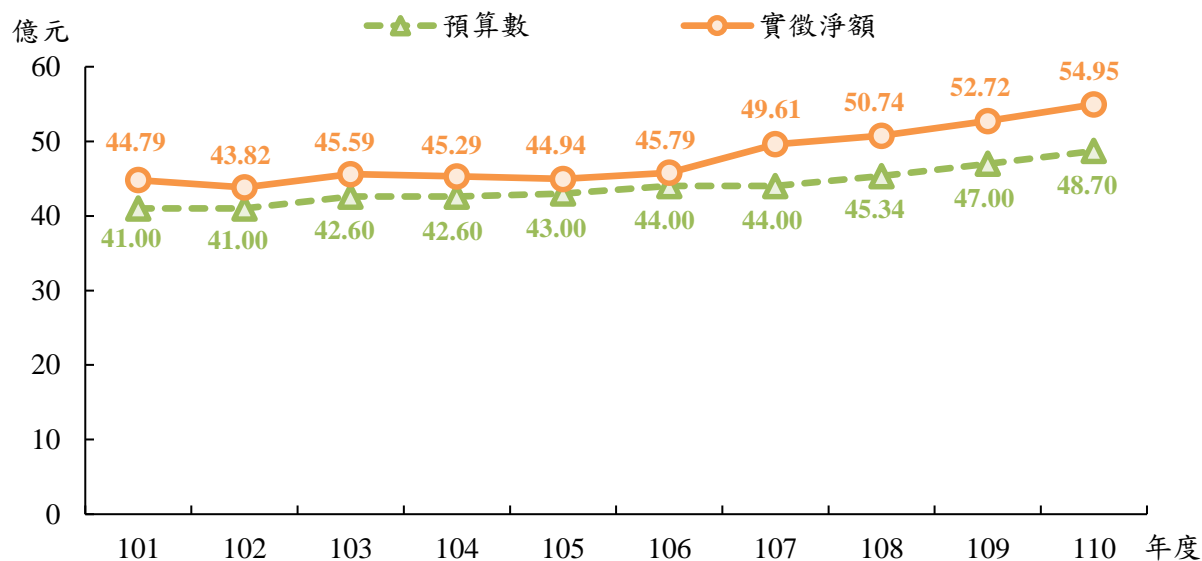
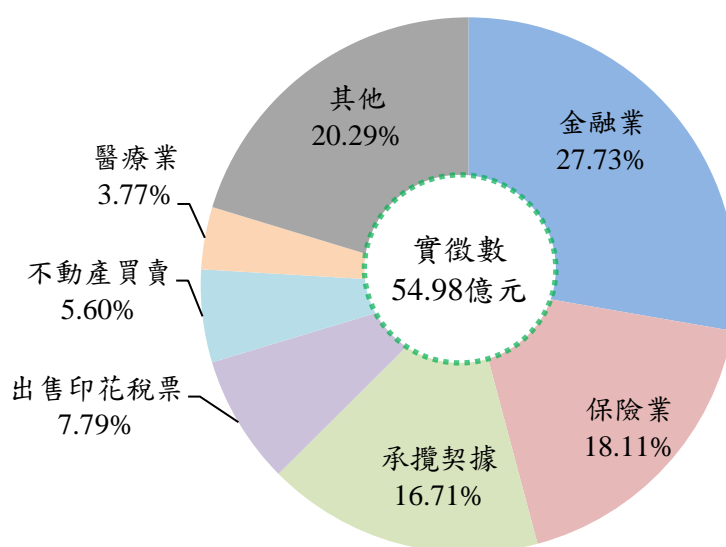
娛樂稅稅源若以實徵數觀察，以視聽視唱業 1,784 萬元最多，占 29.23%，其次臨時公演 1,546 萬元，占 25.32%，再次為電影 1,047 萬元，占 17.16%。(詳圖 16)

圖 15 近 10 年娛樂稅預算數與實徵淨額



圖 16 110 年度娛樂稅稅源



貳、稅收

II . Tax Revenue

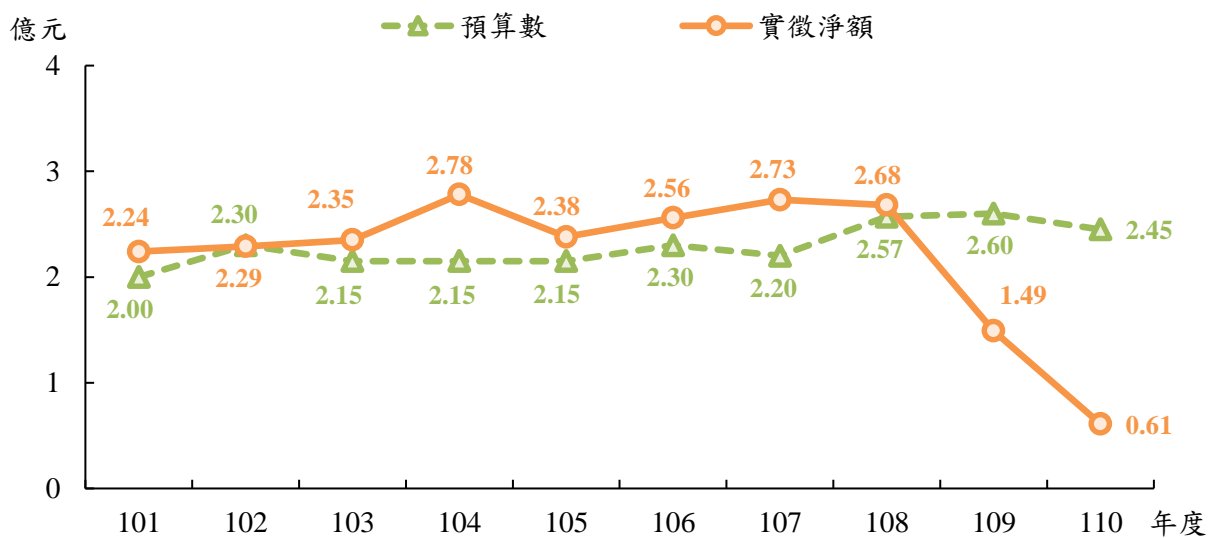
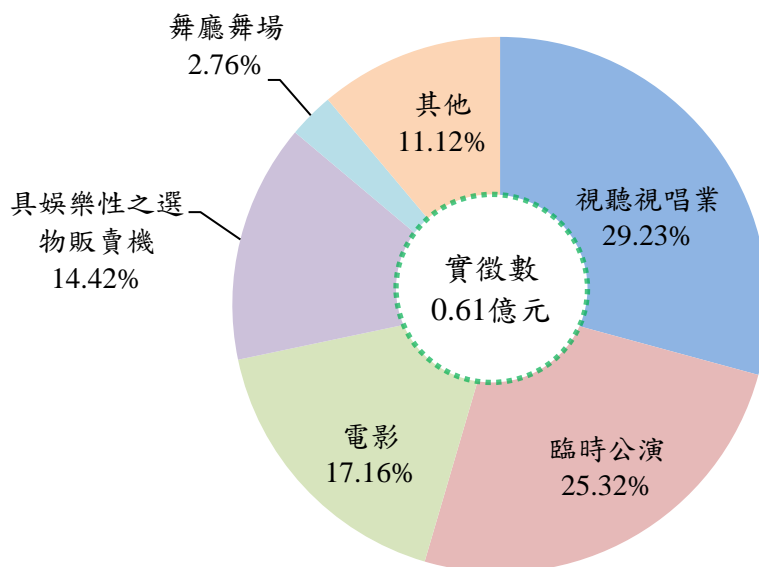
表 2-1 各項稅捐預算數、查定數與實徵數

總計①

單位：新臺幣元

會計年度(月)別 Fiscal Year (Month)		預算數 (1) Budget Amount	查定數 Audited Amount		
			合計 (2)=(3)+(4) Total	本年度 (3) Current FY	以前年度② (4) Previous FY
民國101年度	FY 2012	61,185,000,000	65,905,662,486	62,733,494,186	3,172,168,300
民國102年度	FY 2013	60,561,000,000	69,598,903,684	66,719,824,179	2,879,079,505
民國103年度	FY 2014	63,179,000,000	70,613,134,428	67,876,534,672	2,736,599,756
民國104年度	FY 2015	65,189,000,000	80,029,271,522	77,287,400,028	2,741,871,494
民國105年度	FY 2016	71,652,000,000	78,999,201,336	76,240,367,240	2,758,834,096
民國106年度	FY 2017	75,112,000,000	78,516,005,877	75,465,418,591	3,050,587,286
民國107年度	FY 2018	75,309,000,000	75,199,685,514	71,989,300,681	3,210,384,833
民國108年度	FY 2019	72,712,000,000	77,781,428,378	74,910,059,094	2,871,369,284
民國109年度	FY 2020	73,424,000,000	80,044,957,410	77,356,461,181	2,688,496,229
民國110年度	FY 2021	73,575,795,000	81,155,914,647	77,320,853,467	3,835,061,180
1月	Jan.	2,522,995,000	6,660,121,977	3,031,829,098	3,628,292,879
2月	Feb.	1,470,842,000	1,756,132,431	1,761,705,071	-5,572,640
3月	Mar.	2,652,502,000	2,850,882,125	2,853,854,715	-2,972,590
4月	Apr.	5,254,474,000	7,699,521,492	7,693,805,636	5,715,856
5月	May	13,021,182,000	17,300,885,475	17,289,152,432	11,733,043
6月	June	8,116,805,000	2,904,029,891	2,899,546,359	4,483,532
7月	July	3,317,218,000	2,095,249,101	2,091,887,843	3,361,258
8月	Aug.	1,947,719,000	2,106,177,334	2,080,474,551	25,702,783
9月	Sep.	2,324,369,000	2,287,006,688	2,246,978,521	40,028,167
10月	Oct.	2,081,981,000	4,086,895,256	3,995,388,147	91,507,109
11月	Nov.	16,709,663,000	28,280,472,106	28,232,239,820	48,232,286
12月	Dec.	14,156,045,000	3,128,540,771	3,143,991,274	-15,450,503

資料來源：依據本處徵課會計報告表WAA416及WAA40CP1編製。

說明：①總計=稅捐收入 + 罰鍰收入。稅捐收入=地價稅 + … + 教育捐，罰鍰收入=財務罰鍰 + 罰金罰鍰。

②1月份之以前年度查定數含上年度結轉數。

Table 2-1 Budget Amount, Audited Amount and Actual Collection
Grand Total

實徵數 ^③ Actual Collection			退還以前年度 收入數 ^④ (8) Refund for Revenues of Prvious FY	實徵淨額 (9)=(5)-(8) Net Actual Collection	實徵淨額 占預算數% (10)=(9)/(1) Net Actual Collection/ Budget Amount
合計 (5)=(6)+(7) Total	本年度 (6) Current FY	以前年度 (7) Previous FY			
62,751,393,789	61,392,970,041	1,358,423,748	444,487,791	62,306,905,998	101.8
66,673,882,137	65,467,820,238	1,206,061,899	233,351,037	66,440,531,100	109.7
67,721,827,234	66,736,988,776	984,838,458	328,817,075	67,393,010,159	106.7
77,243,428,036	76,180,207,363	1,063,220,673	325,010,445	76,918,417,591	118.0
75,770,755,206	74,606,116,613	1,164,638,593	361,094,755	75,409,660,451	105.2
75,368,503,602	73,939,299,085	1,429,204,517	376,250,693	74,992,252,909	99.8
72,306,590,399	70,709,743,482	1,596,846,917	402,517,366	71,904,073,033	95.5
75,194,102,689	73,882,211,159	1,311,891,530	431,761,321	74,762,341,368	102.8
76,379,956,745	75,329,161,066	1,050,795,679	526,212,436	75,853,744,309	103.3
77,267,861,451	75,472,185,047	1,795,676,404	490,152,296	76,777,709,155	104.4
3,113,465,532	2,599,162,734	514,302,798	85,679,327	3,027,786,205	120.0
1,663,128,312	1,560,680,811	102,447,501	55,554,714	1,607,573,598	109.3
3,165,916,831	3,068,303,366	97,613,465	65,718,140	3,100,198,691	116.9
5,068,480,243	4,981,355,224	87,125,019	41,524,594	5,026,955,649	95.7
14,812,439,249	14,425,374,658	387,064,591	60,333,236	14,752,106,013	113.3
7,555,613,791	7,373,014,570	182,599,221	37,635,750	7,517,978,041	92.6
2,329,683,488	2,291,437,679	38,245,809	30,077,680	2,299,605,808	69.3
2,242,148,519	2,191,647,670	50,500,849	18,980,253	2,223,168,266	114.1
2,314,435,990	2,255,376,289	59,059,701	14,059,373	2,300,376,617	99.0
3,557,056,327	3,495,251,732	61,804,595	14,946,000	3,542,110,327	170.1
17,713,807,416	17,567,383,012	146,424,404	11,035,582	17,702,771,834	105.9
13,731,685,753	13,663,197,302	68,488,451	54,607,647	13,677,078,106	96.6

說明：③101年度至107年度實徵數未含抵繳稅款實物(以遞延收入入帳)。

④108年度以前為「退還以前年度歲入款」。

表 2-1 各項稅捐預算數、查定數與實徵數 (續1)

一、稅捐收入①

單位：新臺幣元

會計年度(月)別 Fiscal Year (Month)		預算數 (1) Budget Amount	查定數 Audited Amount		
			合計 (2)=(3)+(4) Total	本年度 (3) Current FY	以前年度② (4) Previous FY
民國101年度	FY 2012	61,050,000,000	65,409,563,052	62,634,837,985	2,774,725,067
民國102年度	FY 2013	60,430,000,000	69,105,259,084	66,618,323,432	2,486,935,652
民國103年度	FY 2014	63,075,000,000	70,184,841,864	67,802,361,337	2,382,480,527
民國104年度	FY 2015	65,075,000,000	79,673,033,591	77,226,086,170	2,446,947,421
民國105年度	FY 2016	71,547,000,000	78,640,203,299	76,167,306,395	2,472,896,904
民國106年度	FY 2017	75,014,000,000	78,126,006,033	75,383,120,344	2,742,885,689
民國107年度	FY 2018	75,220,000,000	74,772,122,371	71,883,024,959	2,889,097,412
民國108年度	FY 2019	72,617,000,000	77,268,501,040	74,782,367,568	2,486,133,472
民國109年度	FY 2020	73,331,000,000	79,562,298,477	77,275,767,931	2,286,530,546
民國110年度	FY 2021	73,460,000,000	80,664,845,162	77,241,738,776	3,423,106,386
1月	Jan.	2,517,672,000	6,276,772,502	3,027,001,893	3,249,770,609
2月	Feb.	1,464,404,000	1,751,792,948	1,760,693,910	-8,900,962
3月	Mar.	2,644,907,000	2,841,329,778	2,848,795,722	-7,465,944
4月	Apr.	5,245,513,000	7,690,068,106	7,687,515,605	2,552,501
5月	May	13,006,757,000	17,289,699,168	17,282,596,320	7,102,848
6月	June	8,100,498,000	2,892,152,125	2,889,502,710	2,649,415
7月	July	3,306,397,000	2,087,843,732	2,086,882,834	960,898
8月	Aug.	1,939,343,000	2,100,459,692	2,077,060,012	23,399,680
9月	Sep.	2,316,298,000	2,281,793,145	2,243,683,780	38,109,365
10月	Oct.	2,074,694,000	4,076,843,973	3,987,546,507	89,297,466
11月	Nov.	16,701,649,000	28,262,408,060	28,219,141,093	43,266,967
12月	Dec.	14,141,868,000	3,113,681,933	3,131,318,390	-17,636,457

Table 2-1 Budget Amount, Audited Amount and Actual Collection (Cont.1)

A. Collections of Taxes and Surtaxes

實徵數 ^③ Actual Collection			退還以前年度 收入數 ^④ (8) Refund for Revenues of PrVIOUS FY	實徵淨額 (9)=(5)-(8) Net Actual Collection	實徵淨額 占預算數% (10)=(9)/(1) Net Actual Collection/ Budget Amount
合計 (5)=(6)+(7) Total	本年度 (6) Current FY	以前年度 (7) Previous FY			
62,620,652,883	61,349,810,533	1,270,842,350	431,514,478	62,189,138,405	101.9
66,530,700,040	65,412,535,691	1,118,164,349	219,980,597	66,310,719,443	109.7
67,616,183,545	66,695,912,290	920,271,255	325,059,274	67,291,124,271	106.7
77,142,165,141	76,138,178,495	1,003,986,646	318,801,340	76,823,363,801	118.1
75,678,277,878	74,562,224,169	1,116,053,709	356,466,666	75,321,811,212	105.3
75,257,918,192	73,885,767,803	1,372,150,389	369,058,135	74,888,860,057	99.8
72,200,364,344	70,660,086,558	1,540,277,786	385,633,614	71,814,730,730	95.5
75,062,531,760	73,836,040,873	1,226,490,887	421,440,127	74,641,091,633	102.8
76,270,120,118	75,280,322,703	989,797,415	518,672,868	75,751,447,250	103.3
77,161,622,974	75,423,278,751	1,738,344,223	475,394,991	76,686,227,983	104.4
3,105,158,290	2,598,753,519	506,404,771	84,880,725	3,020,277,565	120.0
1,657,490,189	1,559,872,115	97,618,074	55,200,689	1,602,289,500	109.4
3,157,938,498	3,066,719,957	91,218,541	64,036,028	3,093,902,470	117.0
5,061,433,062	4,979,475,330	81,957,732	39,866,307	5,021,566,755	95.7
14,801,930,369	14,421,134,948	380,795,421	59,240,877	14,742,689,492	113.3
7,543,544,119	7,364,610,683	178,933,436	37,412,734	7,506,131,385	92.7
2,321,955,757	2,287,184,364	34,771,393	29,400,068	2,292,555,689	69.3
2,234,140,357	2,187,737,508	46,402,849	18,772,393	2,215,367,964	114.2
2,309,146,471	2,253,116,372	56,030,099	13,932,744	2,295,213,727	99.1
3,550,843,767	3,492,324,836	58,518,931	13,890,213	3,536,953,554	170.5
17,700,067,790	17,559,460,364	140,607,426	10,487,184	17,689,580,606	105.9
13,717,974,305	13,652,888,755	65,085,550	48,275,029	13,669,699,276	96.7

表 2-1 各項稅捐預算數、查定數與實徵數 (續2)

(一) 地價稅

單位：新臺幣元

會計年度(月)別 Fiscal Year (Month)		預算數 (1) Budget Amount	查定數 Audited Amount		
			合計 (2)=(3)+(4) Total	本年度 (3) Current FY	以前年度② (4) Previous FY
民國101年度	FY 2012	19,500,000,000	21,916,615,715	20,793,949,827	1,122,665,888
民國102年度	FY 2013	21,900,000,000	23,134,506,730	22,091,728,224	1,042,778,506
民國103年度	FY 2014	21,200,000,000	23,465,985,406	22,555,658,532	910,326,874
民國104年度	FY 2015	21,800,000,000	23,120,367,032	22,199,044,067	921,322,965
民國105年度	FY 2016	26,732,000,000	30,901,381,720	29,936,501,857	964,879,863
民國106年度	FY 2017	28,784,000,000	31,076,070,002	29,772,493,181	1,303,576,821
民國107年度	FY 2018	29,200,000,000	28,856,388,971	27,634,421,674	1,221,967,297
民國108年度	FY 2019	27,610,000,000	28,340,231,748	27,321,260,314	1,018,971,434
民國109年度	FY 2020	27,791,000,000	29,251,396,077	28,380,728,335	870,667,742
民國110年度	FY 2021	27,526,000,000	28,922,757,706	27,768,169,981	1,154,587,725
1月	Jan.	77,073,000	1,160,511,993	6,345,436	1,154,166,557
2月	Feb.	46,794,000	33,696,408	30,252,522	3,443,886
3月	Mar.	55,052,000	138,339,307	139,961,931	-1,622,624
4月	Apr.	46,794,000	49,660,820	50,252,421	-591,601
5月	May	46,794,000	12,831,133	10,608,270	2,222,863
6月	June	24,773,000	38,559,051	37,622,800	936,251
7月	July	41,289,000	37,071,605	37,469,100	-397,495
8月	Aug.	96,341,000	16,387,091	15,430,398	956,693
9月	Sep.	104,599,000	95,037,721	95,227,781	-190,060
10月	Oct.	250,487,000	464,236,635	465,174,491	-937,856
11月	Nov.	14,404,356,000	26,046,742,022	26,046,841,580	-99,558
12月	Dec.	12,331,648,000	829,683,920	832,983,251	-3,299,331

Table 2-1 Budget Amount, Audited Amount and Actual Collection (Cont.2)

1. Land Value Tax

實徵數 ^③ Actual Collection			退還以前年度 收入數 ^④ (8) Refund for Revenues of Prvious FY	實徵淨額 (9)=(5)-(8) Net Actual Collection	實徵淨額 占預算數% (10)=(9)/(1) Net Actual Collection/ Budget Amount
合計 (5)=(6)+(7) Total	本年度 (6) Current FY	以前年度 (7) Previous FY			
20,748,021,644	20,243,111,064	504,910,580	77,497,739	20,670,523,905	106.0
22,143,481,947	21,644,233,803	499,248,144	57,150,883	22,086,331,064	100.9
22,520,360,611	22,125,335,251	395,025,360	72,405,760	22,447,954,851	105.9
22,089,792,483	21,715,846,880	373,945,603	49,642,280	22,040,150,203	101.1
29,519,660,662	29,085,483,331	434,177,331	24,121,082	29,495,539,580	110.3
29,837,828,096	29,173,528,221	664,299,875	41,814,851	29,796,013,245	103.5
27,752,119,561	27,086,769,421	665,350,140	109,036,831	27,643,082,730	94.7
27,484,179,451	26,963,746,926	520,432,525	218,764,457	27,265,414,994	98.8
28,088,281,221	27,729,983,704	358,297,517	245,524,738	27,842,756,483	100.2
27,346,906,130	26,946,249,027	400,657,103	207,281,164	27,139,624,966	98.6
74,529,432	3,385,698	71,143,734	34,696,458	39,832,974	51.7
54,626,709	7,816,632	46,810,077	14,885,936	39,740,773	84.9
209,053,634	159,525,092	49,528,542	30,665,004	178,388,630	324.0
74,814,003	30,228,988	44,585,015	11,917,533	62,896,470	134.4
74,619,674	27,659,137	46,960,537	35,310,617	39,309,057	84.0
24,031,084	8,669,229	15,361,855	10,789,314	13,241,770	53.5
28,508,849	9,693,522	18,815,327	13,245,693	15,263,156	37.0
76,831,649	61,234,255	15,597,394	4,714,157	72,117,492	74.9
32,876,403	15,667,072	17,209,331	5,080,984	27,795,419	26.6
541,680,178	527,928,107	13,752,071	3,192,362	538,487,816	215.0
14,747,115,005	14,728,768,113	18,346,892	4,193,812	14,742,921,193	102.4
11,408,219,510	11,365,673,182	42,546,328	38,589,294	11,369,630,216	92.2

表 2-1 各項稅捐預算數、查定數與實徵數 (續3)

(二) 土地增值稅

單位：新臺幣元

會計年度(月)別 Fiscal Year (Month)		預算數 (1) Budget Amount	查定數 Audited Amount		
			合計 (2)=(3)+(4) Total	本年度 (3) Current FY	以前年度② (4) Previous FY
民國101年度	FY 2012	17,000,000,000	17,566,789,041	16,633,841,191	932,947,850
民國102年度	FY 2013	14,200,000,000	20,013,739,423	19,214,772,442	798,966,981
民國103年度	FY 2014	17,000,000,000	20,373,582,528	19,505,216,701	868,365,827
民國104年度	FY 2015	17,600,000,000	26,935,057,700	25,913,549,898	1,021,507,802
民國105年度	FY 2016	18,200,000,000	17,991,803,151	17,041,289,028	950,514,123
民國106年度	FY 2017	18,600,000,000	16,891,442,654	16,105,230,681	786,211,973
民國107年度	FY 2018	17,800,000,000	16,501,257,601	15,551,153,284	950,104,317
民國108年度	FY 2019	16,200,000,000	18,953,630,319	18,229,766,920	723,863,399
民國109年度	FY 2020	16,200,000,000	19,175,972,185	18,507,750,200	668,221,985
民國110年度	FY 2021	16,400,000,000	19,887,573,308	19,062,457,333	825,115,975
1月	Jan.	1,459,600,000	2,700,858,712	1,855,614,475	845,244,237
2月	Feb.	1,118,480,000	1,381,857,436	1,394,803,149	-12,945,713
3月	Mar.	1,300,520,000	1,309,578,685	1,316,179,768	-6,601,083
4月	Apr.	1,420,240,000	1,350,688,790	1,350,447,634	241,156
5月	May	1,497,320,000	1,410,684,471	1,411,508,977	-824,506
6月	June	1,152,920,000	1,906,687,968	1,908,483,056	-1,795,088
7月	July	1,817,120,000	1,089,797,617	1,090,363,075	-565,458
8月	Aug.	1,382,520,000	1,749,440,317	1,745,634,768	3,805,549
9月	Sep.	1,239,840,000	1,199,387,109	1,198,458,898	928,211
10月	Oct.	1,338,240,000	2,754,541,244	2,751,667,585	2,873,659
11月	Nov.	1,167,680,000	1,182,763,221	1,180,431,580	2,331,641
12月	Dec.	1,505,520,000	1,851,287,738	1,858,864,368	-7,576,630

Table 2-1 Budget Amount, Audited Amount and Actual Collection (Cont.3)

2. Land Value Increment Tax

實徵數 ^③ Actual Collection			Unit : N.T.\$		
合計 (5)=(6)+(7) Total	本年度 (6) Current FY	以前年度 (7) Previous FY	退還以前年度 收入數 ^④ (8) Refund for Revenues of Prvious FY	實徵淨額 (9)=(5)-(8) Net Actual Collection	實徵淨額 占預算數% (10)=(9)/(1) Net Actual Collection/ Budget Amount
16,674,777,843	16,137,848,941	536,928,902	277,563,791	16,397,214,052	96.5
19,103,840,213	18,728,768,054	375,072,159	131,046,359	18,972,793,854	133.6
19,303,115,028	19,066,215,194	236,899,834	236,107,832	19,067,007,196	112.2
26,011,486,168	25,568,874,128	442,612,040	243,621,242	25,767,864,926	146.4
17,030,416,543	16,552,918,087	477,498,456	261,093,403	16,769,323,140	92.1
15,868,966,932	15,458,249,801	410,717,131	252,906,867	15,616,060,065	84.0
15,715,752,141	15,158,360,989	557,391,152	260,666,917	15,455,085,224	86.8
18,248,960,029	17,871,349,698	377,610,331	165,555,069	18,083,404,960	111.6
18,301,383,753	17,986,274,543	315,109,210	230,697,001	18,070,686,752	111.5
19,023,679,902	18,621,923,575	401,756,327	199,484,805	18,824,195,097	114.8
1,850,055,830	1,516,990,147	333,065,683	42,285,104	1,807,770,726	123.9
1,254,279,221	1,235,989,493	18,289,728	28,493,495	1,225,785,726	109.6
1,507,735,856	1,492,871,086	14,864,770	22,798,214	1,484,937,642	114.2
1,259,514,585	1,244,516,111	14,998,474	18,946,894	1,240,567,691	87.3
1,366,641,606	1,361,316,889	5,324,717	21,279,524	1,345,362,082	89.9
2,005,830,083	2,003,264,990	2,565,093	9,388,534	1,996,441,549	173.2
1,173,819,453	1,174,154,060	-334,607	15,256,234	1,158,563,219	63.8
1,741,822,311	1,740,370,799	1,451,512	12,260,551	1,729,561,760	125.1
1,168,589,376	1,167,735,844	853,532	6,886,080	1,161,703,296	93.7
2,460,363,739	2,458,410,569	1,953,170	7,636,627	2,452,727,112	183.3
1,464,184,317	1,457,639,735	6,544,582	5,287,227	1,458,897,090	124.9
1,770,843,525	1,768,663,852	2,179,673	8,966,321	1,761,877,204	117.0

表 2-1 各項稅捐預算數、查定數與實徵數 (續4)

(三) 房屋稅

單位：新臺幣元

會計年度(月)別 Fiscal Year (Month)		預算數 (1) Budget Amount	查定數 Audited Amount		
			合計 (2)=(3)+(4) Total	本年度 (3) Current FY	以前年度② (4) Previous FY
民國101年度	FY 2012	11,400,000,000	12,145,931,799	11,853,364,805	292,566,994
民國102年度	FY 2013	11,600,000,000	12,242,328,975	11,981,068,357	261,260,618
民國103年度	FY 2014	12,000,000,000	12,425,932,774	12,183,993,065	241,939,709
民國104年度	FY 2015	12,600,000,000	14,438,403,941	14,239,602,056	198,801,885
民國105年度	FY 2016	13,400,000,000	15,548,887,181	15,318,647,735	230,239,446
民國106年度	FY 2017	13,900,000,000	15,878,783,473	15,669,043,618	209,739,855
民國107年度	FY 2018	14,500,000,000	14,635,288,200	14,446,665,050	188,623,150
民國108年度	FY 2019	14,910,000,000	14,978,856,931	14,781,326,243	197,530,688
民國109年度	FY 2020	15,340,000,000	15,849,518,105	15,694,077,261	155,440,844
民國110年度	FY 2021	15,400,000,000	16,346,331,122	15,623,467,276	722,863,846
1月	Jan.	21,560,000	766,875,974	33,297,095	733,578,879
2月	Feb.	18,480,000	39,875,867	39,138,087	737,780
3月	Mar.	23,100,000	48,468,977	48,933,922	-464,945
4月	Apr.	195,580,000	329,629,052	329,766,305	-137,253
5月	May	8,345,260,000	14,462,878,046	14,463,295,320	-417,274
6月	June	6,144,600,000	516,823,488	516,298,446	525,042
7月	July	401,940,000	70,464,336	70,473,603	-9,267
8月	Aug.	66,220,000	25,528,848	25,496,765	32,083
9月	Sep.	58,520,000	10,537,454	10,564,936	-27,482
10月	Oct.	67,760,000	21,294,252	21,284,567	9,685
11月	Nov.	24,640,000	33,787,901	33,871,969	-84,068
12月	Dec.	32,340,000	20,166,927	31,046,261	-10,879,334

Table 2-1 Budget Amount, Audited Amount and Actual Collection (Cont.4)

3. House Tax

實徵數 ^③ Actual Collection			退還以前年度 收入數 ^④ (8) Refund for Revenues of Prvious FY	實徵淨額 (9)=(5)-(8) Net Actual Collection	實徵淨額 占預算數% (10)=(9)/(1) Net Actual Collection/ Budget Amount
合計 (5)=(6)+(7) Total	本年度 (6) Current FY	以前年度 (7) Previous FY			
11,869,544,305	11,765,750,542	103,793,763	9,609,521	11,859,934,784	104.0
11,997,380,436	11,884,758,971	112,621,465	21,333,121	11,976,047,315	103.2
12,221,541,822	12,093,853,815	127,688,007	4,407,746	12,217,134,076	101.8
14,203,137,405	14,137,990,927	65,146,478	8,028,056	14,195,109,349	112.7
15,328,339,244	15,236,454,042	91,885,202	55,785,281	15,272,553,963	114.0
15,687,184,947	15,592,900,040	94,284,907	61,577,451	15,625,607,496	112.4
14,437,015,400	14,377,465,301	59,550,099	5,071,846	14,431,943,554	99.5
14,822,435,985	14,722,014,520	100,421,465	27,047,842	14,795,388,143	99.2
15,114,495,439	15,054,554,298	59,941,141	24,811,422	15,089,684,017	98.4
15,833,279,254	15,258,888,481	574,390,773	45,998,841	15,787,280,413	102.5
46,532,969	24,192,331	22,340,638	3,359,468	43,173,501	200.2
43,032,386	28,273,262	14,759,124	11,124,837	31,907,549	172.7
63,334,322	51,432,123	11,902,199	9,868,894	53,465,428	231.5
324,930,581	314,556,519	10,374,062	7,720,809	317,209,772	162.2
9,799,396,824	9,487,017,307	312,379,517	1,434,681	9,797,962,143	117.4
4,995,866,079	4,843,405,601	152,460,478	5,618,460	4,990,247,619	81.2
191,642,542	182,459,628	9,182,914	605,129	191,037,413	47.5
54,650,684	47,352,711	7,297,973	1,560,886	53,089,798	80.2
82,604,544	76,427,106	6,177,438	1,937,904	80,666,640	137.8
70,112,150	62,699,200	7,412,950	1,500,750	68,611,400	101.3
76,485,416	69,288,778	7,196,638	630,720	75,854,696	307.9
84,690,757	71,783,915	12,906,842	636,303	84,054,454	259.9

表 2-1 各項稅捐預算數、查定數與實徵數 (續5)

(四) 使用牌照稅

單位：新臺幣元

會計年度(月)別 Fiscal Year (Month)		預算數 (1) Budget Amount	查定數 Audited Amount		
			合計 (2)=(3)+(4) Total	本年度 (3) Current FY	以前年度② (4) Previous FY
民國101年度	FY 2012	6,450,000,000	7,210,013,827	6,833,694,476	376,319,351
民國102年度	FY 2013	6,600,000,000	7,286,652,627	6,966,480,016	320,172,611
民國103年度	FY 2014	6,600,000,000	7,407,801,179	7,137,466,677	270,334,502
民國104年度	FY 2015	6,800,000,000	7,689,616,970	7,436,140,040	253,476,930
民國105年度	FY 2016	6,900,000,000	7,810,668,145	7,525,219,941	285,448,204
民國106年度	FY 2017	7,300,000,000	7,859,805,423	7,542,552,703	317,252,720
民國107年度	FY 2018	7,400,000,000	7,924,669,207	7,572,035,153	352,634,054
民國108年度	FY 2019	7,566,000,000	7,930,568,581	7,512,037,790	418,530,791
民國109年度	FY 2020	7,500,000,000	7,876,694,855	7,456,648,824	420,046,031
民國110年度	FY 2021	7,450,000,000	7,854,958,991	7,420,783,788	434,175,203
1月	Jan.	117,710,000	544,766,641	109,852,247	434,914,394
2月	Feb.	85,675,000	75,699,664	75,792,533	-92,869
3月	Mar.	408,260,000	453,380,072	453,496,546	-116,474
4月	Apr.	3,345,050,000	5,659,597,411	5,659,692,838	-95,427
5月	May	2,259,075,000	492,131,537	492,235,618	-104,081
6月	June	522,755,000	176,716,440	176,720,495	-4,055
7月	July	111,005,000	24,330,642	24,327,944	2,698
8月	Aug.	78,225,000	5,879,315	5,879,097	218
9月	Sep.	48,425,000	35,038,809	35,072,743	-33,934
10月	Oct.	141,550,000	373,504,583	373,595,578	-90,995
11月	Nov.	310,665,000	8,700,888	8,850,477	-149,589
12月	Dec.	21,605,000	5,212,989	5,267,672	-54,683

Table 2-1 Budget Amount, Audited Amount and Actual Collection (Cont.5)

4. Vehicle License Tax

實徵數 ^③ Actual Collection			退還以前年度 收入數 ^④ (8) Refund for Revenues of Prvious FY	實徵淨額 (9)=(5)-(8) Net Actual Collection	實徵淨額 占預算數% (10)=(9)/(1) Net Actual Collection/ Budget Amount
合計 (5)=(6)+(7) Total	本年度 (6) Current FY	以前年度 (7) Previous FY			
6,833,177,948	6,746,233,733	86,944,215	5,451,652	6,827,726,296	105.9
6,955,441,436	6,877,052,975	78,388,461	5,347,283	6,950,094,153	105.3
7,118,817,681	7,040,294,793	78,522,888	4,939,003	7,113,878,678	107.8
7,403,407,388	7,323,486,127	79,921,261	3,706,191	7,399,701,197	108.8
7,484,074,599	7,402,428,814	81,645,785	3,914,641	7,480,159,958	108.4
7,509,640,047	7,420,360,586	89,279,461	3,868,134	7,505,771,913	102.8
7,508,024,520	7,412,614,465	95,410,055	5,591,520	7,502,433,000	101.4
7,512,359,770	7,395,795,225	116,564,545	4,077,694	7,508,282,076	99.2
7,443,558,518	7,344,262,323	99,296,195	10,228,325	7,433,330,193	99.1
7,397,863,010	7,306,595,649	91,267,361	7,960,019	7,389,902,991	99.2
118,152,861	96,382,544	21,770,317	3,880,430	114,272,431	97.1
91,725,338	77,459,408	14,265,930	213,758	91,511,580	106.8
465,701,625	453,112,617	12,589,008	91,037	465,610,588	114.0
3,117,672,226	3,108,533,113	9,139,113	482,521	3,117,189,705	93.2
2,653,234,490	2,644,520,859	8,713,631	1,150,577	2,652,083,913	117.4
240,189,020	234,693,631	5,495,389	59,624	240,129,396	45.9
63,610,464	58,916,302	4,694,162	82,357	63,528,107	57.2
68,977,323	65,391,576	3,585,747	222,322	68,755,001	87.9
95,941,052	92,823,132	3,117,920	27,152	95,913,900	198.1
98,383,449	95,335,587	3,047,862	1,477,726	96,905,723	68.5
344,588,266	342,297,980	2,290,286	236,545	344,351,721	110.8
39,686,896	37,128,900	2,557,996	35,970	39,650,926	183.5

表 2-1 各項稅捐預算數、查定數與實徵數 (續6)

(五) 契稅

單位：新臺幣元

會計年度(月)別 Fiscal Year (Month)		預算數 (1) Budget Amount	查定數 Audited Amount		
			合計 (2)=(3)+(4) Total	本年度 (3) Current FY	以前年度② (4) Previous FY
民國101年度	FY 2012	2,400,000,000	1,801,127,687	1,789,084,593	12,043,094
民國102年度	FY 2013	1,800,000,000	1,734,852,208	1,715,325,749	19,526,459
民國103年度	FY 2014	1,800,000,000	1,681,135,183	1,666,281,819	14,853,364
民國104年度	FY 2015	1,800,000,000	2,635,476,618	2,615,259,099	20,217,519
民國105年度	FY 2016	1,800,000,000	1,610,624,175	1,605,091,654	5,532,521
民國106年度	FY 2017	1,800,000,000	1,540,948,039	1,518,313,118	22,634,921
民國107年度	FY 2018	1,700,000,000	1,576,218,448	1,557,178,616	19,039,832
民國108年度	FY 2019	1,540,000,000	1,677,642,146	1,655,600,974	22,041,172
民國109年度	FY 2020	1,540,000,000	1,927,262,474	1,902,860,908	24,401,566
民國110年度	FY 2021	1,569,000,000	2,033,341,706	2,008,096,246	25,245,460
1月	Jan.	129,783,000	266,414,736	240,861,563	25,553,173
2月	Feb.	100,873,000	118,307,988	118,571,624	-263,636
3月	Mar.	127,649,000	153,370,246	153,301,055	69,191
4月	Apr.	110,744,000	170,727,020	170,668,788	58,232
5月	May	144,350,000	190,790,232	190,788,291	1,941
6月	June	131,772,000	136,442,206	136,432,642	9,564
7月	July	180,119,000	112,887,143	112,868,568	18,575
8月	Aug.	127,262,000	149,528,367	149,523,909	4,458
9月	Sep.	135,143,000	149,750,140	149,743,924	6,216
10月	Oct.	133,813,000	185,141,432	185,141,432	-
11月	Nov.	124,159,000	179,008,636	178,957,144	51,492
12月	Dec.	123,333,000	220,973,560	221,237,306	-263,746

Table 2-1 Budget Amount, Audited Amount and Actual Collection (Cont.6)

5. Deed Tax

實徵數 ^③ Actual Collection			退還以前年度 收入數 ^④ (8) Refund for Revenues of Prvious FY	實徵淨額 (9)=(5)-(8) Net Actual Collection	實徵淨額 占預算數% (10)=(9)/(1) Net Actual Collection/ Budget Amount
合計 (5)=(6)+(7) Total	本年度 (6) Current FY	以前年度 (7) Previous FY			
1,779,320,448	1,767,832,856	11,487,592	48,554,638	1,730,765,810	72.1
1,718,308,296	1,699,547,000	18,761,296	3,357,047	1,714,951,249	95.3
1,656,050,355	1,641,731,846	14,318,509	5,414,521	1,650,635,834	91.7
2,619,757,703	2,599,963,241	19,794,462	6,636,420	2,613,121,283	145.2
1,582,985,477	1,577,826,873	5,158,604	10,726,625	1,572,258,852	87.3
1,514,720,163	1,492,438,414	22,281,749	4,214,800	1,510,505,363	83.9
1,553,242,722	1,534,689,401	18,553,321	4,424,987	1,548,817,735	91.1
1,650,385,663	1,628,835,264	21,550,399	3,511,366	1,646,874,297	106.9
1,896,931,512	1,872,991,193	23,940,319	3,414,882	1,893,516,630	123.0
2,003,097,116	1,978,090,692	25,006,424	13,782,365	1,989,314,751	126.8
232,531,564	208,682,540	23,849,024	567,749	231,963,815	178.7
112,509,729	112,224,133	285,596	256,946	112,252,783	111.3
168,016,719	167,931,543	85,176	237,768	167,778,951	131.4
163,712,981	163,695,894	17,087	692,419	163,020,562	147.2
183,066,775	182,369,472	697,303	65,478	183,001,297	126.8
158,407,153	158,388,526	18,627	11,550,580	146,856,573	111.4
117,512,850	117,504,936	7,914	204,389	117,308,461	65.1
136,210,129	136,177,707	32,422	10,770	136,199,359	107.0
143,871,811	143,865,595	6,216	-	143,871,811	106.5
180,685,749	180,685,749	-	23,790	180,661,959	135.0
183,690,590	183,690,590	-	136,229	183,554,361	147.8
222,881,066	222,874,007	7,059	36,247	222,844,819	180.7

表 2-1 各項稅捐預算數、查定數與實徵數 (續7)

(六) 印花稅

單位：新臺幣元

會計年度(月)別 Fiscal Year (Month)		預算數 (1) Budget Amount	查定數 Audited Amount		
			合計 (2)=(3)+(4) Total	本年度 (3) Current FY	以前年度② (4) Previous FY
民國101年度	FY 2012	4,100,000,000	4,528,289,507	4,503,633,420	24,656,087
民國102年度	FY 2013	4,100,000,000	4,450,816,446	4,420,195,497	30,620,949
民國103年度	FY 2014	4,260,000,000	4,582,705,985	4,517,168,088	65,537,897
民國104年度	FY 2015	4,260,000,000	4,564,573,534	4,544,318,777	20,254,757
民國105年度	FY 2016	4,300,000,000	4,525,491,724	4,500,617,981	24,873,743
民國106年度	FY 2017	4,400,000,000	4,608,481,500	4,518,125,272	90,356,228
民國107年度	FY 2018	4,400,000,000	4,991,010,102	4,848,047,340	142,962,762
民國108年度	FY 2019	4,534,000,000	5,103,606,258	5,013,048,444	90,557,814
民國109年度	FY 2020	4,700,000,000	5,312,659,568	5,181,362,919	131,296,649
民國110年度	FY 2021	4,870,000,000	5,541,270,696	5,299,744,868	241,525,828
1月	Jan.	695,923,000	802,979,802	766,262,493	36,717,309
2月	Feb.	79,868,000	95,504,937	95,273,639	231,298
3月	Mar.	714,916,000	732,092,657	730,868,955	1,223,702
4月	Apr.	115,419,000	123,594,385	120,512,584	3,081,801
5月	May	699,332,000	711,596,117	705,377,343	6,218,774
6月	June	111,036,000	113,154,481	110,174,392	2,980,089
7月	July	730,987,000	753,129,308	751,175,772	1,953,536
8月	Aug.	158,762,000	153,517,968	134,916,056	18,601,912
9月	Sep.	701,767,000	790,753,227	753,334,455	37,418,772
10月	Oct.	113,958,000	276,109,350	188,665,005	87,444,345
11月	Nov.	644,301,000	807,814,489	766,597,466	41,217,023
12月	Dec.	103,731,000	181,023,975	176,586,708	4,437,267

Table 2-1 Budget Amount, Audited Amount and Actual Collection (Cont.7)

6. Stamp Tax

實徵數 ^③ Actual Collection			退還以前年度 收入數 ^④ (8) Refund for Revenues of Prvious FY	實徵淨額 (9)=(5)-(8) Net Actual Collection	實徵淨額 占預算數% (10)=(9)/(1) Net Actual Collection/ Budget Amount
合計 (5)=(6)+(7) Total	本年度 (6) Current FY	以前年度 (7) Previous FY			
4,490,891,015	4,466,449,592	24,441,423	12,319,234	4,478,571,781	109.2
4,383,222,779	4,352,816,494	30,406,285	1,721,851	4,381,500,928	106.9
4,561,138,863	4,495,847,841	65,291,022	1,542,838	4,559,596,025	107.0
4,536,481,104	4,516,226,347	20,254,757	7,140,578	4,529,340,526	106.3
4,494,834,400	4,470,080,858	24,753,542	805,052	4,494,029,348	104.5
4,582,909,637	4,492,881,740	90,027,897	4,189,004	4,578,720,633	104.1
4,961,433,626	4,818,601,110	142,832,516	835,940	4,960,597,686	112.7
5,076,359,813	4,987,841,599	88,518,214	2,424,394	5,073,935,419	111.9
5,276,274,851	5,145,506,486	130,768,365	3,873,437	5,272,401,414	112.2
5,495,647,109	5,254,573,645	241,073,464	781,203	5,494,865,906	112.8
768,174,503	735,012,935	33,161,568	9,996	768,164,507	110.4
94,788,953	91,917,841	2,871,112	220,594	94,568,359	118.4
738,010,951	736,088,100	1,922,851	366,405	737,644,546	103.2
114,825,815	112,227,524	2,598,291	103,137	114,722,678	99.4
716,592,837	710,057,393	6,535,444	-	716,592,837	102.5
115,369,201	112,515,597	2,853,604	4,470	115,364,731	103.9
745,969,907	744,016,855	1,953,052	6,266	745,963,641	102.0
153,766,415	136,197,138	17,569,277	3,707	153,762,708	96.9
783,812,330	755,266,692	28,545,638	-	783,812,330	111.7
197,441,744	165,263,074	32,178,670	58,168	197,383,576	173.2
880,369,930	774,235,604	106,134,326	-	880,369,930	136.6
186,524,523	181,774,892	4,749,631	8,460	186,516,063	179.8

表 2-1 各項稅捐預算數、查定數與實徵數 (續8)

(七) 娛樂稅

單位：新臺幣元

會計年度(月)別 Fiscal Year (Month)		預算數 (1) Budget Amount	查定數 Audited Amount		
			合計 (2)=(3)+(4) Total	本年度 (3) Current FY	以前年度② (4) Previous FY
民國101年度	FY 2012	200,000,000	239,594,695	227,269,673	12,325,022
民國102年度	FY 2013	230,000,000	241,617,104	228,753,147	12,863,957
民國103年度	FY 2014	215,000,000	247,274,144	236,576,455	10,697,689
民國104年度	FY 2015	215,000,000	289,194,798	278,172,233	11,022,565
民國105年度	FY 2016	215,000,000	251,001,805	239,938,199	11,063,606
民國106年度	FY 2017	230,000,000	270,417,166	257,361,771	13,055,395
民國107年度	FY 2018	220,000,000	287,287,603	273,523,842	13,763,761
民國108年度	FY 2019	257,000,000	283,962,818	269,326,883	14,635,935
民國109年度	FY 2020	260,000,000	168,794,869	152,339,484	16,455,385
民國110年度	FY 2021	245,000,000	78,611,633	59,019,284	19,592,349
1月	Jan.	16,023,000	34,364,644	14,768,584	19,596,060
2月	Feb.	14,234,000	6,850,648	6,862,356	-11,708
3月	Mar.	15,410,000	6,099,834	6,053,545	46,289
4月	Apr.	11,686,000	6,170,628	6,175,035	-4,407
5月	May	14,626,000	8,787,632	8,782,501	5,131
6月	June	12,642,000	3,768,080	3,770,468	-2,388
7月	July	23,937,000	163,081	204,772	-41,691
8月	Aug.	30,013,000	177,786	179,019	-1,233
9月	Sep.	28,004,000	1,289,096	1,281,454	7,642
10月	Oct.	28,886,000	2,016,477	2,017,849	-1,372
11月	Nov.	25,848,000	3,590,903	3,590,877	26
12月	Dec.	23,691,000	5,332,824	5,332,824	-

Table 2-1 Budget Amount, Audited Amount and Actual Collection (Cont.8)

7. Amusement Tax

實徵數 ^③ Actual Collection			退還以前年度 收入數 ^④ (8) Refund for Revenues of Prvious FY	實徵淨額 (9)=(5)-(8) Net Actual Collection	實徵淨額 占預算數% (10)=(9)/(1) Net Actual Collection/ Budget Amount
合計 (5)=(6)+(7) Total	本年度 (6) Current FY	以前年度 (7) Previous FY			
224,615,319	222,583,805	2,031,514	477,451	224,137,868	112.1
228,951,423	225,358,394	3,593,029	24,053	228,927,370	99.5
235,077,518	232,633,550	2,443,968	202,710	234,874,808	109.2
278,102,890	275,790,845	2,312,045	24,607	278,078,283	129.3
237,963,515	237,032,164	931,351	20,582	237,942,933	110.7
256,668,370	255,409,001	1,259,369	487,028	256,181,342	111.4
272,776,374	271,585,871	1,190,503	5,573	272,770,801	124.0
267,848,810	266,457,641	1,391,169	49,910	267,798,900	104.2
149,194,480	146,750,156	2,444,324	98,983	149,095,497	57.3
61,150,453	56,957,682	4,192,771	106,290	61,044,163	24.9
15,181,131	14,107,324	1,073,807	81,216	15,099,915	94.2
6,527,853	6,191,346	336,507	5,123	6,522,730	45.8
6,085,391	5,759,396	325,995	8,706	6,076,685	39.4
5,962,871	5,717,181	245,690	2,994	5,959,877	51.0
8,378,163	8,193,891	184,272	-	8,378,163	57.3
3,851,499	3,673,109	178,390	1,752	3,849,747	30.5
891,692	439,061	452,631	-	891,692	3.7
1,881,846	1,013,322	868,524	-	1,881,846	6.3
1,450,955	1,330,931	120,024	624	1,450,331	5.2
2,176,758	2,002,550	174,208	790	2,175,968	7.5
3,634,266	3,539,564	94,702	2,651	3,631,615	14.0
5,128,028	4,990,007	138,021	2,434	5,125,594	21.6

表 2-1 各項稅捐預算數、查定數與實徵數 (續9)

(八) 教育捐

單位：新臺幣元

會計年度(月)別 Fiscal Year (Month)		預算數 (1) Budget Amount	查定數 Audited Amount		
			合計 (2)=(3)+(4) Total	本年度 (3) Current FY	以前年度② (4) Previous FY
民國101年度	FY 2012	-	1,200,781	-	1,200,781
民國102年度	FY 2013	-	745,571	-	745,571
民國103年度	FY 2014	-	424,665	-	424,665
民國104年度	FY 2015	-	342,998	-	342,998
民國105年度	FY 2016	-	345,398	-	345,398
民國106年度	FY 2017	-	57,776	-	57,776
民國107年度	FY 2018	-	2,239	-	2,239
民國108年度	FY 2019	-	2,239	-	2,239
民國109年度	FY 2020	-	344	-	344
民國110年度	FY 2021	-	-	-	-
1月	Jan.	-	-	-	-
2月	Feb.	-	-	-	-
3月	Mar.	-	-	-	-
4月	Apr.	-	-	-	-
5月	May	-	-	-	-
6月	June	-	411	411	-
7月	July	-	-	-	-
8月	Aug.	-	-	-	-
9月	Sep.	-	-411	-411	-
10月	Oct.	-	-	-	-
11月	Nov.	-	-	-	-
12月	Dec.	-	-	-	-
房屋稅附徵	Surtax On House Tax	-	-	-	-
娛樂稅附徵	Surtax On Amusement Tax	-	-	-	-
契稅附徵	Surtax On Deed Tax	-	-	-	-

Table 2-1 Budget Amount, Audited Amount and Actual Collection (Cont.9)

8. Education Surtax

實徵數 ^③ Actual Collection			Unit : N.T.\$			
合計 (5)=(6)+(7) Total	本年度 (6) Current FY	以前年度 (7) Previous FY	退還以前年度 收入數 ^④ (8) Refund for Revenues of Prvious FY	實徵淨額 (9)=(5)-(8) Net Actual Collection	實徵淨額 占預算數% (10)=(9)/(1) Net Actual Collection/ Budget Amount	
304,361	-	304,361	40,452	263,909	--	
73,510	-	73,510	-	73,510	--	
81,667	-	81,667	38,864	42,803	--	
-	-	-	1,966	-1,966	--	
3,438	-	3,438	-	3,438	--	
-	-	-	-	-	--	
-	-	-	-	-	--	
2,239	-	2,239	9,395	-7,156	--	
344	-	344	24,080	-23,736	--	
-	-	-	304	-304	--	
-	-	-	304	-304	--	
-	-	-	-	-	--	
-	-	-	-	-	--	
-	-	-	-	-	--	
-	-	-	-	-	--	
-	-	-	-	-	--	
-	-	-	-	-	--	
-	-	-	-	-	--	
-	-	-	-	-	--	
-	-	-	-	-	--	
-	-	-	304	-304	--	
-	-	-	-	-	--	
-	-	-	-	-	--	

表 2-1 各項稅捐預算數、查定數與實徵數 (續10)

二、罰鍰收入①

單位：新臺幣元

會計年度(月)別 Fiscal Year (Month)		預算數 (1) Budget Amount	查定數 Audited Amount		
			合計 (2)=(3)+(4) Total	本年度 (3) Current FY	以前年度② (4) Previous FY
民國101年度	FY 2012	135,000,000	496,099,434	98,656,201	397,443,233
民國102年度	FY 2013	131,000,000	493,644,600	101,500,747	392,143,853
民國103年度	FY 2014	104,000,000	428,292,564	74,173,335	354,119,229
民國104年度	FY 2015	114,000,000	356,237,931	61,313,858	294,924,073
民國105年度	FY 2016	105,000,000	358,998,037	73,060,845	285,937,192
民國106年度	FY 2017	98,000,000	389,999,844	82,298,247	307,701,597
民國107年度	FY 2018	89,000,000	427,563,143	106,275,722	321,287,421
民國108年度	FY 2019	95,000,000	512,927,338	127,691,526	385,235,812
民國109年度	FY 2020	93,000,000	482,658,933	80,693,250	401,965,683
民國110年度	FY 2021	115,795,000	491,069,485	79,114,691	411,954,794
1月	Jan.	5,323,000	383,349,475	4,827,205	378,522,270
2月	Feb.	6,438,000	4,339,483	1,011,161	3,328,322
3月	Mar.	7,595,000	9,552,347	5,058,993	4,493,354
4月	Apr.	8,961,000	9,453,386	6,290,031	3,163,355
5月	May	14,425,000	11,186,307	6,556,112	4,630,195
6月	June	16,307,000	11,877,766	10,043,649	1,834,117
7月	July	10,821,000	7,405,369	5,005,009	2,400,360
8月	Aug.	8,376,000	5,717,642	3,414,539	2,303,103
9月	Sep.	8,071,000	5,213,543	3,294,741	1,918,802
10月	Oct.	7,287,000	10,051,283	7,841,640	2,209,643
11月	Nov.	8,014,000	18,064,046	13,098,727	4,965,319
12月	Dec.	14,177,000	14,858,838	12,672,884	2,185,954

Table 2-1 Budget Amount, Audited Amount and Actual Collection (Cont.10)

B. Punitive Fine Revenue

實徵數 ^③ Actual Collection			退還以前年度 收入數 ^④ (8) Refund for Revenues of Prvious FY	實徵淨額 (9)=(5)-(8) Net Actual Collection	實徵淨額 占預算數% (10)=(9)/(1) Net Actual Collection/ Budget Amount
合計 (5)=(6)+(7) Total	本年度 (6) Current FY	以前年度 (7) Previous FY			
130,740,906	43,159,508	87,581,398	12,973,313	117,767,593	87.2
143,182,097	55,284,547	87,897,550	13,370,440	129,811,657	99.1
105,643,689	41,076,486	64,567,203	3,757,801	101,885,888	98.0
101,262,895	42,028,868	59,234,027	6,209,105	95,053,790	83.4
92,477,328	43,892,444	48,584,884	4,628,089	87,849,239	83.7
110,585,410	53,531,282	57,054,128	7,192,558	103,392,852	105.5
106,226,055	49,656,924	56,569,131	16,883,752	89,342,303	100.4
131,570,929	46,170,286	85,400,643	10,321,194	121,249,735	127.6
109,836,627	48,838,363	60,998,264	7,539,568	102,297,059	110.0
106,238,477	48,906,296	57,332,181	14,757,305	91,481,172	79.0
8,307,242	409,215	7,898,027	798,602	7,508,640	141.1
5,638,123	808,696	4,829,427	354,025	5,284,098	82.1
7,978,333	1,583,409	6,394,924	1,682,112	6,296,221	82.9
7,047,181	1,879,894	5,167,287	1,658,287	5,388,894	60.1
10,508,880	4,239,710	6,269,170	1,092,359	9,416,521	65.3
12,069,672	8,403,887	3,665,785	223,016	11,846,656	72.6
7,727,731	4,253,315	3,474,416	677,612	7,050,119	65.2
8,008,162	3,910,162	4,098,000	207,860	7,800,302	93.1
5,289,519	2,259,917	3,029,602	126,629	5,162,890	64.0
6,212,560	2,926,896	3,285,664	1,055,787	5,156,773	70.8
13,739,626	7,922,648	5,816,978	548,398	13,191,228	164.6
13,711,448	10,308,547	3,402,901	6,332,618	7,378,830	52.0

表 2-1 各項稅捐預算數、查定數與實徵數(續11)

(一) 財務罰鍰

單位：新臺幣元

會計年度(月)別 Fiscal Year (Month)		預算數 (1) Budget Amount	查定數 Audited Amount		
			合計 (2)=(3)+(4) Total	本年度 (3) Current FY	以前年度② (4) Previous FY
民國101年度	FY 2012	55,000,000	422,025,628	76,500,925	345,524,703
民國102年度	FY 2013	51,000,000	406,813,046	73,938,384	332,874,662
民國103年度	FY 2014	44,000,000	365,674,364	49,072,511	316,601,853
民國104年度	FY 2015	44,000,000	292,022,883	32,906,212	259,116,671
民國105年度	FY 2016	41,000,000	299,472,468	46,623,261	252,849,207
民國106年度	FY 2017	34,000,000	318,336,653	54,384,774	263,951,879
民國107年度	FY 2018	31,000,000	358,366,402	79,986,697	278,379,705
民國108年度	FY 2019	35,000,000	420,400,874	100,322,149	320,078,725
民國109年度	FY 2020	36,000,000	410,617,541	48,178,269	362,439,272
民國110年度	FY 2021	38,000,000	421,017,701	48,915,718	372,101,983
1月	Jan.	1,823,000	377,262,133	4,766,657	372,495,476
2月	Feb.	2,938,000	840,244	926,105	-85,861
3月	Mar.	2,955,000	4,444,816	4,497,291	-52,475
4月	Apr.	4,469,000	6,068,571	6,057,328	11,243
5月	May	3,279,000	3,179,865	3,158,742	21,123
6月	June	3,044,000	2,146,076	2,183,259	-37,183
7月	July	3,275,000	1,291,795	1,294,259	-2,464
8月	Aug.	3,707,000	1,135,045	1,177,817	-42,772
9月	Sep.	3,527,000	2,279,875	2,299,186	-19,311
10月	Oct.	2,721,000	6,872,889	6,822,727	50,162
11月	Nov.	2,185,000	10,844,868	10,858,813	-13,945
12月	Dec.	4,077,000	4,651,524	4,873,534	-222,010

Table 2-1 Budget Amount, Audited Amount and Actual Collection (Cont.11)

1. Financial Penalty

實徵數 ^③ Actual Collection			退還以前年度 收入數 ^④	實徵淨額	實徵淨額 占預算數%
合計 (5)=(6)+(7)	本年度 (6)	以前年度 (7)	(8)	(9)=(5)-(8)	(10)=(9)/(1)
Total	Current FY	Previous FY	Refund for Revenues of Prvious FY	Net Actual Collection	Net Actual Collection/ Budget Amount
56,735,033	21,004,232	35,730,801	616,250	56,118,783	102.0
56,350,543	27,722,184	28,628,359	248,162	56,102,381	110.0
43,025,489	15,975,662	27,049,827	303,761	42,721,728	97.1
37,047,847	13,621,222	23,426,625	1,536,843	35,511,004	80.7
33,028,090	17,454,860	15,573,230	899,668	32,128,422	78.4
38,922,219	25,617,809	13,304,410	705,829	38,216,390	112.4
37,029,314	23,367,899	13,661,415	417,166	36,612,148	118.1
39,044,465	18,800,909	20,243,556	128,962	38,915,503	111.2
37,960,726	16,393,457	21,567,269	289,601	37,671,125	104.6
36,352,184	18,707,323	17,644,861	136,558	36,215,626	95.3
2,385,391	348,667	2,036,724	11,800	2,373,591	130.2
2,138,884	723,640	1,415,244	-	2,138,884	72.8
2,870,802	1,021,707	1,849,095	8,158	2,862,644	96.9
3,662,366	1,647,191	2,015,175	3,369	3,658,997	81.9
2,502,438	842,340	1,660,098	12,084	2,490,354	75.9
2,337,982	543,497	1,794,485	-	2,337,982	76.8
1,614,157	542,565	1,071,592	-	1,614,157	49.3
3,425,565	1,673,440	1,752,125	8,320	3,417,245	92.2
2,355,851	1,264,362	1,091,489	-	2,355,851	66.8
3,034,166	1,907,983	1,126,183	90,262	2,943,904	108.2
6,520,448	5,682,734	837,714	-	6,520,448	298.4
3,504,134	2,509,197	994,937	2,565	3,501,569	85.9

表 2-1 各項稅捐預算數、查定數與實徵數 (續12完)

(二) 罰金罰鍰

單位：新臺幣元

會計年度(月)別 Fiscal Year (Month)		預算數 (1) Budget Amount	查定數 Audited Amount		
			合計 (2)=(3)+(4) Total	本年度 (3) Current FY	以前年度② (4) Previous FY
民國101年度	FY 2012	80,000,000	74,073,806	22,155,276	51,918,530
民國102年度	FY 2013	80,000,000	86,831,554	27,562,363	59,269,191
民國103年度	FY 2014	60,000,000	62,618,200	25,100,824	37,517,376
民國104年度	FY 2015	70,000,000	64,215,048	28,407,646	35,807,402
民國105年度	FY 2016	64,000,000	59,525,569	26,437,584	33,087,985
民國106年度	FY 2017	64,000,000	71,663,191	27,913,473	43,749,718
民國107年度	FY 2018	58,000,000	69,196,741	26,289,025	42,907,716
民國108年度	FY 2019	60,000,000	92,526,464	27,369,377	65,157,087
民國109年度	FY 2020	57,000,000	72,041,392	32,514,981	39,526,411
民國110年度	FY 2021	77,795,000	70,051,784	30,198,973	39,852,811
1月	Jan.	3,500,000	6,087,342	60,548	6,026,794
2月	Feb.	3,500,000	3,499,239	85,056	3,414,183
3月	Mar.	4,640,000	5,107,531	561,702	4,545,829
4月	Apr.	4,492,000	3,384,815	232,703	3,152,112
5月	May	11,146,000	8,006,442	3,397,370	4,609,072
6月	June	13,263,000	9,731,690	7,860,390	1,871,300
7月	July	7,546,000	6,113,574	3,710,750	2,402,824
8月	Aug.	4,669,000	4,582,597	2,236,722	2,345,875
9月	Sep.	4,544,000	2,933,668	995,555	1,938,113
10月	Oct.	4,566,000	3,178,394	1,018,913	2,159,481
11月	Nov.	5,829,000	7,219,178	2,239,914	4,979,264
12月	Dec.	10,100,000	10,207,314	7,799,350	2,407,964

Table 2-1 Budget Amount, Audited Amount and Actual Collection (Cont.12 End)

2. Belated Surcharge

實徵數 ^③ Actual Collection			退還以前年度	實徵淨額	實徵淨額
合計	本年度	以前年度	收入數 ^④		占預算數%
(5)=(6)+(7)	(6)	(7)	(8)	(9)=(5)-(8)	(10)=(9)/(1)
Total	Current FY	Previous FY	Refund for Revenues of Prvious FY	Net Actual Collection	Net Actual Collection/ Budget Amount
74,005,873	22,155,276	51,850,597	12,357,063	61,648,810	77.1
86,831,554	27,562,363	59,269,191	13,122,278	73,709,276	92.1
62,618,200	25,100,824	37,517,376	3,454,040	59,164,160	98.6
64,215,048	28,407,646	35,807,402	4,672,262	59,542,786	85.1
59,449,238	26,437,584	33,011,654	3,728,421	55,720,817	87.1
71,663,191	27,913,473	43,749,718	6,486,729	65,176,462	101.8
69,196,741	26,289,025	42,907,716	16,466,586	52,730,155	90.9
92,526,464	27,369,377	65,157,087	10,192,232	82,334,232	137.2
71,875,901	32,444,906	39,430,995	7,249,967	64,625,934	113.4
69,886,293	30,198,973	39,687,320	14,620,747	55,265,546	71.0
5,921,851	60,548	5,861,303	786,802	5,135,049	146.7
3,499,239	85,056	3,414,183	354,025	3,145,214	89.9
5,107,531	561,702	4,545,829	1,673,954	3,433,577	74.0
3,384,815	232,703	3,152,112	1,654,918	1,729,897	38.5
8,006,442	3,397,370	4,609,072	1,080,275	6,926,167	62.1
9,731,690	7,860,390	1,871,300	223,016	9,508,674	71.7
6,113,574	3,710,750	2,402,824	677,612	5,435,962	72.0
4,582,597	2,236,722	2,345,875	199,540	4,383,057	93.9
2,933,668	995,555	1,938,113	126,629	2,807,039	61.8
3,178,394	1,018,913	2,159,481	965,525	2,212,869	48.5
7,219,178	2,239,914	4,979,264	548,398	6,670,780	114.4
10,207,314	7,799,350	2,407,964	6,330,053	3,877,261	38.4

表 2-2 各項稅捐實徵淨額與結構比

單位：新臺幣元

稅目別 Item of Tax	101年度 FY 2012		102年度 FY 2013	
	實徵淨額 Net Actual Collection	結構比 Structure Ratio %	實徵淨額 Net Actual Collection	結構比 Structure Ratio %
總計 Grand Total	62,306,905,998	100.00	66,440,531,100	100.00
稅捐收入 Collections of Taxes and Surtaxes	62,189,138,405	99.81	66,310,719,443	99.80
地價稅 Land Vaule Tax	20,670,523,905	33.18	22,086,331,064	33.24
土地增值稅 Land Value Increment Tax	16,397,214,052	26.32	18,972,793,854	28.56
房屋稅 House Tax	11,859,934,784	19.03	11,976,047,315	18.03
使用牌照稅 Vehicle License Tax	6,827,726,296	10.96	6,950,094,153	10.46
契稅 Deed Tax	1,730,765,810	2.78	1,714,951,249	2.58
印花稅 Stamp Tax	4,478,571,781	7.19	4,381,500,928	6.59
娛樂稅 Amusement Tax	224,137,868	0.36	228,927,370	0.34
特別稅 Special Tax Levies	-	-	-	-
臨時稅 Provisional Tax Levies	-	-	-	-
教育捐 Education Surtax	263,909	0.00	73,510	0.00
工程受益費 Construction Benefit Fee	-	-	-	-
罰鍰收入 Punitive Fine Revenue	117,767,593	0.19	129,811,657	0.20
財務罰鍰 Financial Penalty	56,118,783	0.09	56,102,381	0.08
罰金罰鍰 Belated Surcharge	61,648,810	0.10	73,709,276	0.11

資料來源：依據本處會計室報表WAA40CP1。

Table 2-2 Net Actual Collection and Structure Ratio in Recent Years

Unit : N.T.\$

103年度 FY 2014		104年度 FY 2015		105年度 FY 2016	
實徵淨額 Net Actual Collection	結構比 Structure Ratio %	實徵淨額 Net Actual Collection	結構比 Structure Ratio %	實徵淨額 Net Actual Collection	結構比 Structure Ratio %
67,393,010,159	100.00	76,918,417,591	100.00	75,409,660,451	100.00
67,291,124,271	99.85	76,823,363,801	99.88	75,321,811,212	99.88
22,447,954,851	33.31	22,040,150,203	28.65	29,495,539,580	39.11
19,067,007,196	28.29	25,767,864,926	33.50	16,769,323,140	22.24
12,217,134,076	18.13	14,195,109,349	18.45	15,272,553,963	20.25
7,113,878,678	10.56	7,399,701,197	9.62	7,480,159,958	9.92
1,650,635,834	2.45	2,613,121,283	3.40	1,572,258,852	2.08
4,559,596,025	6.77	4,529,340,526	5.89	4,494,029,348	5.96
234,874,808	0.35	278,078,283	0.36	237,942,933	0.32
-	-	-	-	-	-
-	-	-	-	-	-
42,803	0.00	- 1,966	--	3,438	0.00
-	-	-	-	-	-
101,885,888	0.15	95,053,790	0.12	87,849,239	0.12
42,721,728	0.06	35,511,004	0.05	32,128,422	0.04
59,164,160	0.09	59,542,786	0.08	55,720,817	0.07

表 2-2 各項稅捐實徵淨額與結構比 (續1完)

單位：新臺幣元

稅目別 Item of Tax	106年度 FY 2017		107年度 FY 2018	
	實徵淨額 Net Actual Collection	結構比 Structure Ratio %	實徵淨額 Net Actual Collection	結構比 Structure Ratio %
總計 Grand Total	74,992,252,909	100.00	71,904,073,033	100.00
稅捐收入 Collections of Taxes and Surtaxes	74,888,860,057	99.86	71,814,730,730	99.88
地價稅 Land Vaule Tax	29,796,013,245	39.73	27,643,082,730	38.44
土地增值稅 Land Value Increment Tax	15,616,060,065	20.82	15,455,085,224	21.49
房屋稅 House Tax	15,625,607,496	20.84	14,431,943,554	20.07
使用牌照稅 Vehicle License Tax	7,505,771,913	10.01	7,502,433,000	10.43
契稅 Deed Tax	1,510,505,363	2.01	1,548,817,735	2.15
印花稅 Stamp Tax	4,578,720,633	6.11	4,960,597,686	6.90
娛樂稅 Amusement Tax	256,181,342	0.34	272,770,801	0.38
特別稅 Special Tax Levies	-	-	-	-
臨時稅 Provisional Tax Levies	-	-	-	-
教育捐 Education Surtax	-	-	-	-
工程受益費 Construction Benefit Fee	-	-	-	-
罰鍰收入 Punitive Fine Revenue	103,392,852	0.14	89,342,303	0.12
財務罰鍰 Financial Penalty	38,216,390	0.05	36,612,148	0.05
罰金罰鍰 Belated Surcharge	65,176,462	0.09	52,730,155	0.07

Table 2-2 Net Actual Collection and Structure Ratio in Recent Years (Cont.1 End)

Unit : N.T.\$

108年度 FY 2019		109年度 FY 2020		110年度 FY 2021	
實徵淨額 Net Actual Collection	結構比 Structure Ratio %	實徵淨額 Net Actual Collection	結構比 Structure Ratio %	實徵淨額 Net Actual Collection	結構比 Structure Ratio %
74,762,341,368	100.00	75,853,744,309	100.00	76,777,709,155	100.00
74,641,091,633	99.84	75,751,447,250	99.87	76,686,227,983	99.88
27,265,414,994	36.47	27,842,756,483	36.71	27,139,624,966	35.35
18,083,404,960	24.19	18,070,686,752	23.82	18,824,195,097	24.52
14,795,388,143	19.79	15,089,684,017	19.89	15,787,280,413	20.56
7,508,282,076	10.04	7,433,330,193	9.80	7,389,902,991	9.63
1,646,874,297	2.20	1,893,516,630	2.50	1,989,314,751	2.59
5,073,935,419	6.79	5,272,401,414	6.95	5,494,865,906	7.16
267,798,900	0.36	149,095,497	0.20	61,044,163	0.08
-	-	-	-	-	-
-	-	-	-	-	-
- 7,156	--	- 23,736	--	- 304	--
-	-	-	-	-	-
121,249,735	0.16	102,297,059	0.13	91,481,172	0.12
38,915,503	0.05	37,671,125	0.05	36,215,626	0.05
82,334,232	0.11	64,625,934	0.09	55,265,546	0.07

表 2-3 各項稅捐繳付公庫數

總計①

單位：新臺幣元

會計年度及稅目別 Fiscal Year & Item of Tax		實徵淨額 Net Actual Collection	繳付公庫數		
			合計 Total	國庫 The National Treasury	中央統籌分配專戶 Distribution of Central Gov't
民國101年度	FY 2012	62,306,905,998	62,306,905,998	-	-
民國102年度	FY 2013	66,440,531,100	66,440,531,100	-	-
民國103年度	FY 2014	67,393,010,159	67,393,010,159	-	-
民國104年度	FY 2015	76,918,417,591	76,918,417,591	-	-
民國105年度	FY 2016	75,409,660,451	75,409,660,451	-	-
民國106年度	FY 2017	74,992,252,909	74,992,252,909	-	-
民國107年度	FY 2018	71,904,073,033	71,904,073,033	-	-
民國108年度	FY 2019	74,762,341,368	74,762,341,368	-	-
民國109年度	FY 2020	75,853,744,309	75,853,744,309	-	-
民國110年度	FY 2021	76,777,709,155	76,777,709,155	-	-
稅捐收入 Collections of Taxes and Surtaxes		76,686,227,983	76,686,227,983	-	-
地價稅 Land Vaule Tax		27,139,624,966	27,139,624,966	-	-
土地增值稅 Land Value Increment Tax		18,824,195,097	18,824,195,097	-	-
房屋稅 House Tax		15,787,280,413	15,787,280,413	-	-
使用牌照稅 Vehicle License Tax		7,389,902,991	7,389,902,991	-	-
契稅 Deed Tax		1,989,314,751	1,989,314,751	-	-
印花稅 Stamp Tax		5,494,865,906	5,494,865,906	-	-
娛樂稅 Amusement Tax		61,044,163	61,044,163	-	-
特別稅 Special Tax Levies		-	-	-	-
臨時稅 Provisional Tax Levies		-	-	-	-
教育捐 Education Surtax		-304	-304	-	-
工程受益費 Construction Benefit Fee		-	-	-	-
罰鍰收入 Punitive Fine Revenue		91,481,172	91,481,172	-	-
財務罰鍰 Financial Penalty		36,215,626	36,215,626	-	-
罰金罰鍰 Belated Surcharge		55,265,546	55,265,546	-	-

資料來源：依據本處會計室徵課會計報告表WAA40CP1編製，107年度以前表報代號為WAA402P。
 說明：①總計=本年度+以前年度-收回以前年度繳付數。

Table 2-3 Taxation Forwarded to Treasury

Grand Total

Pay to Treasury						Unit : N.T.\$
重建基金庫	直轄市庫	市庫	縣庫	縣統籌分配專戶	鄉鎮庫	未繳付公庫數 ②
Reconstruction Fund	Municipality Treasury	City Treasury	County Treasury	Account Distributed by County	Township Treasuries	Unforwarded to Treasury
-	62,306,905,998	-	-	-	-	59,489,460
-	66,440,531,100	-	-	-	-	59,451,157
-	67,393,010,159	-	-	-	-	59,451,157
-	76,918,417,591	-	-	-	-	59,396,611
-	75,409,660,451	-	-	-	-	60,060,477
-	74,992,252,909	-	-	-	-	60,040,250
-	71,904,073,033	-	-	-	-	60,040,250
-	74,762,341,368	-	-	-	-	60,040,250
-	75,853,744,309	-	-	-	-	60,040,250
-	76,777,709,155	-	-	-	-	60,040,250
-	76,686,227,983	-	-	-	-	58,710,566
-	27,139,624,966	-	-	-	-	9,502,854
-	18,824,195,097	-	-	-	-	49,207,712
-	15,787,280,413	-	-	-	-	-
-	7,389,902,991	-	-	-	-	-
-	1,989,314,751	-	-	-	-	-
-	5,494,865,906	-	-	-	-	-
-	61,044,163	-	-	-	-	-
-	-	-	-	-	-	-
-	-	-	-	-	-	-
-	-304	-	-	-	-	-
-	-	-	-	-	-	601,994
-	91,481,172	-	-	-	-	727,690
-	36,215,626	-	-	-	-	-
-	55,265,546	-	-	-	-	727,690

說明：②係為本處徵課會計表報代號WAA305P2之歷年抵繳稅款實物。

表 2-3 各項稅捐繳付公庫數 (續1)

一、本年度

單位：新臺幣元

會計年度及稅目別 Fiscal Year & Item of Tax		實徵數 Actual Collection	繳付公庫數		
			合計 Total	國庫 The National Treasury	中央統籌分配專戶 Distribution of Central Gov't
民國101年度	FY 2012	61,392,970,041	61,392,970,041	-	-
民國102年度	FY 2013	65,467,820,238	65,467,820,238	-	-
民國103年度	FY 2014	66,736,988,776	66,736,988,776	-	-
民國104年度	FY 2015	76,180,207,363	76,180,207,363	-	-
民國105年度	FY 2016	74,606,116,613	74,606,116,613	-	-
民國106年度	FY 2017	73,939,299,085	73,939,299,085	-	-
民國107年度	FY 2018	70,709,743,482	70,709,743,482	-	-
民國108年度	FY 2019	73,882,211,159	73,882,211,159	-	-
民國109年度	FY 2020	75,329,161,066	75,329,161,066	-	-
民國110年度	FY 2021	75,472,185,047	75,472,185,047	-	-
稅捐收入 Collections of Taxes and Surtaxes		75,423,278,751	75,423,278,751	-	-
地價稅 Land Vaule Tax		26,946,249,027	26,946,249,027	-	-
土地增值稅 Land Value Increment Tax		18,621,923,575	18,621,923,575	-	-
房屋稅 House Tax		15,258,888,481	15,258,888,481	-	-
使用牌照稅 Vehicle License Tax		7,306,595,649	7,306,595,649	-	-
契稅 Deed Tax		1,978,090,692	1,978,090,692	-	-
印花稅 Stamp Tax		5,254,573,645	5,254,573,645	-	-
娛樂稅 Amusement Tax		56,957,682	56,957,682	-	-
特別稅 Special Tax Levies		-	-	-	-
臨時稅 Provisional Tax Levies		-	-	-	-
教育捐 Education Surtax		-	-	-	-
工程受益費 Construction Benefit Fee		-	-	-	-
罰鍰收入 Punitive Fine Revenue		48,906,296	48,906,296	-	-
財務罰鍰 Financial Penalty		18,707,323	18,707,323	-	-
罰金罰鍰 Belated Surcharge		30,198,973	30,198,973	-	-

Table 2-3 Taxation Forwarded to Treasury (Cont.1)

A. Current Fiscal Year

Pay to Treasury						Unit : N.T.\$
重建基金庫	直轄市庫	市庫	縣庫	縣統籌分配專戶	鄉鎮庫	未繳付公庫數 ②
Reconstruction Fund	Municipality Treasury	City Treasury	County Treasury	Account Distributed by County	Township Treasuries	Unforwarded to Treasury
-	61,392,970,041	-	-	-	-	-
-	65,467,820,238	-	-	-	-	-
-	66,736,988,776	-	-	-	-	-
-	76,180,207,363	-	-	-	-	-
-	74,606,116,613	-	-	-	-	-
-	73,939,299,085	-	-	-	-	-
-	70,709,743,482	-	-	-	-	-
-	73,882,211,159	-	-	-	-	-
-	75,329,161,066	-	-	-	-	-
-	75,472,185,047	-	-	-	-	-
-	75,423,278,751	-	-	-	-	-
-	26,946,249,027	-	-	-	-	-
-	18,621,923,575	-	-	-	-	-
-	15,258,888,481	-	-	-	-	-
-	7,306,595,649	-	-	-	-	-
-	1,978,090,692	-	-	-	-	-
-	5,254,573,645	-	-	-	-	-
-	56,957,682	-	-	-	-	-
-	-	-	-	-	-	-
-	-	-	-	-	-	-
-	-	-	-	-	-	-
-	-	-	-	-	-	-
-	48,906,296	-	-	-	-	-
-	18,707,323	-	-	-	-	-
-	30,198,973	-	-	-	-	-

表 2-3 各項稅捐繳付公庫數 (續2)

二、以前年度

單位：新臺幣元

會計年度及稅目別 Fiscal Year & Item of Tax		實徵數 Actual Collection	繳付公庫數		
			合計 Total	國庫 The National Treasury	中央統籌分配專戶 Distribution of Central Gov't
民國101年度	FY 2012	1,358,423,748	1,358,423,748	-	-
民國102年度	FY 2013	1,206,061,899	1,206,061,899	-	-
民國103年度	FY 2014	984,838,458	984,838,458	-	-
民國104年度	FY 2015	1,063,220,673	1,063,220,673	-	-
民國105年度	FY 2016	1,164,638,593	1,164,638,593	-	-
民國106年度	FY 2017	1,429,204,517	1,429,204,517	-	-
民國107年度	FY 2018	1,596,846,917	1,596,846,917	-	-
民國108年度	FY 2019	1,311,891,530	1,311,891,530	-	-
民國109年度	FY 2020	1,050,795,679	1,050,795,679	-	-
民國110年度	FY 2021	1,795,676,404	1,795,676,404	-	-
稅捐收入 Collections of Taxes and Surtaxes		1,738,344,223	1,738,344,223	-	-
地價稅 Land Vaule Tax		400,657,103	400,657,103	-	-
土地增值稅 Land Value Increment Tax		401,756,327	401,756,327	-	-
房屋稅 House Tax		574,390,773	574,390,773	-	-
使用牌照稅 Vehicle License Tax		91,267,361	91,267,361	-	-
契稅 Deed Tax		25,006,424	25,006,424	-	-
印花稅 Stamp Tax		241,073,464	241,073,464	-	-
娛樂稅 Amusement Tax		4,192,771	4,192,771	-	-
特別稅 Special Tax Levies		-	-	-	-
臨時稅 Provisional Tax Levies		-	-	-	-
教育捐 Education Surtax		-	-	-	-
工程受益費 Construction Benefit Fee		-	-	-	-
罰鍰收入 Punitive Fine Revenue		57,332,181	57,332,181	-	-
財務罰鍰 Financial Penalty		17,644,861	17,644,861	-	-
罰金罰鍰 Belated Surcharge		39,687,320	39,687,320	-	-

Table 2-3 Taxation Forwarded to Treasury (Cont.2)

B. Previous Fiscal Year

Unit : N.T.\$

Pay to Treasury						未繳付公庫數 ②
重建基金庫	直轄市庫	市庫	縣庫	縣統籌分配專戶	鄉鎮庫	Unforwarded to Treasury
Reconstruction Fund	Municipality Treasury	City Treasury	County Treasury	Account Distributed by County	Township Treasuries	
-	1,358,423,748	-	-	-	-	59,489,460
-	1,206,061,899	-	-	-	-	59,451,157
-	984,838,458	-	-	-	-	59,451,157
-	1,063,220,673	-	-	-	-	59,396,611
-	1,164,638,593	-	-	-	-	60,060,477
-	1,429,204,517	-	-	-	-	60,040,250
-	1,596,846,917	-	-	-	-	60,040,250
-	1,311,891,530	-	-	-	-	60,040,250
-	1,050,795,679	-	-	-	-	60,040,250
-	1,795,676,404	-	-	-	-	60,040,250
-	1,738,344,223	-	-	-	-	58,710,566
-	400,657,103	-	-	-	-	9,502,854
-	401,756,327	-	-	-	-	49,207,712
-	574,390,773	-	-	-	-	-
-	91,267,361	-	-	-	-	-
-	25,006,424	-	-	-	-	-
-	241,073,464	-	-	-	-	-
-	4,192,771	-	-	-	-	-
-	-	-	-	-	-	-
-	-	-	-	-	-	-
-	-	-	-	-	-	-
-	-	-	-	-	-	601,994
-	57,332,181	-	-	-	-	727,690
-	17,644,861	-	-	-	-	-
-	39,687,320	-	-	-	-	727,690

表 2-3 各項稅捐繳付公庫數(續3完)

三、收回以前年度繳付數

單位：新臺幣元

會計年度及稅目別 Fiscal Year & Item of Tax		退還以前年度 收入數 Refund for Revenues of Previous FY	繳付公庫數		
			合計 Total	國庫 The National Treasury	中央統籌分配專戶 Distribution of Central Gov't
民國101年度	FY 2012	444,487,791	444,487,791	-	-
民國102年度	FY 2013	233,351,037	233,351,037	-	-
民國103年度	FY 2014	328,817,075	328,817,075	-	-
民國104年度	FY 2015	325,010,445	325,010,445	-	-
民國105年度	FY 2016	361,094,755	361,094,755	-	-
民國106年度	FY 2017	376,250,693	376,250,693	-	-
民國107年度	FY 2018	402,517,366	402,517,366	-	-
民國108年度	FY 2019	431,761,321	431,761,321	-	-
民國109年度	FY 2020	526,212,436	526,212,436	-	-
民國110年度	FY 2021	490,152,296	490,152,296	-	-
稅捐收入 Collections of Taxes and Surtaxes		475,394,991	475,394,991	-	-
地價稅 Land Vaule Tax		207,281,164	207,281,164	-	-
土地增值稅 Land Value Increment Tax		199,484,805	199,484,805	-	-
房屋稅 House Tax		45,998,841	45,998,841	-	-
使用牌照稅 Vehicle License Tax		7,960,019	7,960,019	-	-
契稅 Deed Tax		13,782,365	13,782,365	-	-
印花稅 Stamp Tax		781,203	781,203	-	-
娛樂稅 Amusement Tax		106,290	106,290	-	-
特別稅 Special Tax Levies		-	-	-	-
臨時稅 Provisional Tax Levies		-	-	-	-
教育捐 Education Surtax		304	304	-	-
工程受益費 Construction Benefit Fee		-	-	-	-
罰鍰收入 Punitive Fine Revenue		14,757,305	14,757,305	-	-
財務罰鍰 Financial Penalty		136,558	136,558	-	-
罰金罰鍰 Belated Surcharge		14,620,747	14,620,747	-	-

Table 2-3 Taxation Forwarded to Treasury (Cont.3 End)

C. Tax Refund for Previous Years

Unit : N.T.\$

Pay to Treasury					
重建基金庫	直轄市庫	市庫	縣庫	縣統籌分配專戶	鄉鎮庫
Reconstruction Fund	Municipality Treasury	City Treasury	County Treasury	Account Distributed by County	Township Treasuries
-	444,487,791	-	-	-	-
-	233,351,037	-	-	-	-
-	328,817,075	-	-	-	-
-	325,010,445	-	-	-	-
-	361,094,755	-	-	-	-
-	376,250,693	-	-	-	-
-	402,517,366	-	-	-	-
-	431,761,321	-	-	-	-
-	526,212,436	-	-	-	-
-	490,152,296	-	-	-	-
-	475,394,991	-	-	-	-
-	207,281,164	-	-	-	-
-	199,484,805	-	-	-	-
-	45,998,841	-	-	-	-
-	7,960,019	-	-	-	-
-	13,782,365	-	-	-	-
-	781,203	-	-	-	-
-	106,290	-	-	-	-
-	-	-	-	-	-
-	-	-	-	-	-
-	304	-	-	-	-
-	-	-	-	-	-
-	14,757,305	-	-	-	-
-	136,558	-	-	-	-
-	14,620,747	-	-	-	-

表 2-4 各項稅捐徵績比較

單位：新臺幣元

稅目別 Item of Tax	110 年 度			
	預算數 Budget Amount	查定數① Audited Amount	實徵數 Actual Collection	退還以前年度 收入數 Refund for Revenues of Previous FY
總計 Grand Total	73,575,795,000	81,155,914,647	77,267,861,451	490,152,296
稅捐收入 Collections of Taxes and Surtaxes	73,460,000,000	80,664,845,162	77,161,622,974	475,394,991
地價稅 Land Vaule Tax	27,526,000,000	28,922,757,706	27,346,906,130	207,281,164
土地增值稅 Land Value Increment Tax	16,400,000,000	19,887,573,308	19,023,679,902	199,484,805
房屋稅 House Tax	15,400,000,000	16,346,331,122	15,833,279,254	45,998,841
使用牌照稅 Vehicle License Tax	7,450,000,000	7,854,958,991	7,397,863,010	7,960,019
契稅 Deed Tax	1,569,000,000	2,033,341,706	2,003,097,116	13,782,365
印花稅 Stamp Tax	4,870,000,000	5,541,270,696	5,495,647,109	781,203
娛樂稅 Amusement Tax	245,000,000	78,611,633	61,150,453	106,290
特別稅 Special Tax Levies	-	-	-	-
臨時稅 Provisional Tax Levies	-	-	-	-
教育捐 Education Surtax	-	-	-	304
工程受益費 Construction Benefit Fee	-	-	-	-
罰鍰收入 Punitive Fine Revenue	115,795,000	491,069,485	106,238,477	14,757,305
財務罰鍰 Financial Penalty	38,000,000	421,017,701	36,352,184	136,558
罰金罰鍰 Belated Surcharge	77,795,000	70,051,784	69,886,293	14,620,747

資料來源：依據本處徵課會計報告編製。

說明：①查定數包括以前年度結轉數。

Table 2-4 Net Tax Revenues Compare

Unit : N.T.\$

FY 2021			110 年度與 109 年度比較 Compare FY2021 with FY2020		
實徵淨額 Net Actual Collection	實徵數 占預算數% Actual Collection/ Budget Amount	實徵淨額 占預算數% Net Actual Collection/ Budget Amount	109 年度 實徵淨額 Net Actual Collection FY 2020	增減數 Amount	增減 %
76,777,709,155	105.0	104.4	75,853,744,309	923,964,846	1.2
76,686,227,983	105.0	104.4	75,751,447,250	934,780,733	1.2
27,139,624,966	99.3	98.6	27,842,756,483	-703,131,517	-2.5
18,824,195,097	116.0	114.8	18,070,686,752	753,508,345	4.2
15,787,280,413	102.8	102.5	15,089,684,017	697,596,396	4.6
7,389,902,991	99.3	99.2	7,433,330,193	-43,427,202	-0.6
1,989,314,751	127.7	126.8	1,893,516,630	95,798,121	5.1
5,494,865,906	112.8	112.8	5,272,401,414	222,464,492	4.2
61,044,163	25.0	24.9	149,095,497	-88,051,334	-59.1
-	--	--	-	-	--
-	--	--	-	-	--
-304	--	--	-23,736	23,432	--
-	--	--	-	-	--
91,481,172	91.7	79.0	102,297,059	-10,815,887	-10.6
36,215,626	95.7	95.3	37,617,125	-1,401,499	-3.7
55,265,546	89.8	71.0	64,625,934	-9,360,388	-14.5

本 頁 空 白

參、稅源及其他

III . Tax Sources and Others

表 3-1 地價稅稅源

一、稅地種類分析

單位：戶、公頃、新臺幣千元

會計年度及地種別 Fiscal Year & Classification	都市土地及非都市土地				
	戶數 No. of Landowners			課稅面積	
	合計 Total	公有 Public	私有 Private	合計 Total	公有 Public
民國 101年度 FY 2012	860,251	312	859,939	5,034.7634	420.6052
民國 102年度 FY 2013	867,911	346	867,565	4,951.7003	323.4543
民國 103年度 FY 2014	875,372	397	874,975	4,971.4676	329.6468
民國 104年度 FY 2015	881,734	460	881,274	4,952.6736	311.4796
民國 105年度 FY 2016	889,256	508	888,748	4,957.1873	312.1464
民國 106年度 FY 2017	894,347	515	893,832	4,976.3728	324.9699
民國 107年度 FY 2018	898,348	561	897,787	4,987.6353	331.1581
民國 108年度 FY 2019	904,929	564	904,365	4,991.6602	317.4395
民國 109年度 FY 2020	911,642	679	910,963	5,005.4775	315.7453
民國 110年度 FY 2021	919,266	736	918,530	5,023.2730	339.4047
一般土地 Regular Land	393,530	716	392,814	2,624.6496	313.0652
第一級 Level 1	390,336	716	389,620	1,869.6404	313.0652
第二級 Level 2	2,777	-	2,777	351.1578	-
第三級 Level 3	218	-	218	88.8597	-
第四級 Level 4	74	-	74	46.6005	-
第五級 Level 5	32	-	32	30.4377	-
第六級 Level 6	93	-	93	237.9536	-
自用住宅用地 Self-use Residence Land	522,547	8	522,539	2,178.4052	18.9514
工礦業等用地 Specific Business Land	59	-	59	99.5790	0.2445
公共設施保留地 Land Reserved for Public Facilities	3,130	12	3,118	120.6391	7.1435
加徵空地稅用地 Vacant Site	-	-	-	-	-
免稅用地 Exempt Land	22,933	-	-	-	-
小額免稅 Small Amount Exempt Land	53,732	-	-	2.0691	-

資料來源：依據本處財產稅科報表20903-02-01編製，103年度以前表號為2613-02-01。

Table 3-1 Sources of Land Value Tax

A. Analysis for the Kinds of Land

Unit : Unit; Hectare; NT\$1,000

Urban Land and Non-Urban Land						
Area	課稅地價 Taxed Land Value			地價稅額 Land Value Tax		
私有 Private	合計 Total	公有 Public	私有 Private	合計 Total	公有 Public	私有 Private
4,614.1581	2,096,510,787	157,495,462	1,939,015,325	20,339,436	1,506,856	18,832,580
4,628.2459	2,247,409,509	178,607,411	2,068,802,098	22,164,453	1,722,533	20,441,921
4,641.8207	2,253,998,074	183,596,673	2,070,401,401	22,260,505	1,763,128	20,497,377
4,641.1939	2,242,518,610	171,807,887	2,070,710,723	22,048,902	1,658,740	20,390,162
4,645.0408	2,999,585,466	234,256,605	2,765,328,861	29,681,879	2,270,747	27,411,131
4,651.4028	3,006,897,174	239,746,264	2,767,150,910	29,221,409	2,325,966	26,895,443
4,656.4772	2,838,088,758	230,489,233	2,607,599,525	27,369,465	2,237,446	25,132,018
4,674.2208	2,834,791,609	222,945,731	2,611,845,878	27,214,179	2,164,441	25,049,737
4,689.7322	2,866,417,885	224,051,971	2,642,365,914	27,574,981	2,173,565	25,401,416
4,683.8683	2,874,281,969	241,429,415	2,632,852,554	27,330,520	2,344,487	24,986,033
2,311.5844	1,514,131,340	230,705,635	1,283,425,705	24,015,459	2,307,056	21,708,403
1,556.5752	1,019,138,836	230,705,635	788,433,202	10,191,208	2,307,056	7,884,152
351.1578	186,036,567	-	186,036,567	2,326,167	-	2,326,167
88.8597	55,277,108	-	55,277,108	927,721	-	927,721
46.6005	36,035,453	-	36,035,453	790,884	-	790,884
30.4377	20,981,121	-	20,981,121	557,548	-	557,548
237.9536	196,662,254	-	196,662,254	9,221,931	-	9,221,931
2,159.4538	1,274,887,500	6,863,443	1,268,024,057	2,549,486	13,727	2,535,759
99.3345	63,502,698	135,631	63,367,067	635,027	1,356	633,670
113.4956	21,760,431	3,724,706	18,035,725	130,549	22,348	108,200
-	-	-	-	-	-	-
-	-	-	-	-	-	-
-	170,810	-	-	1,819	-	-

表 3-1 地價稅稅源 (續1完)

二、減免稅地概況

單位：筆、公頃、新臺幣千元

會計年度及地種別 Fiscal Year & Classification	都市土地及非都市土地			
	筆數 Plots			面積
	合計 Total	公有 Public	私有 Private	合計 Total
民國 101年度 FY 2012	511,319	108,795	402,524	8,853.3791
民國 102年度 FY 2013	553,570	131,708	421,862	12,314.6353
民國 103年度 FY 2014	565,905	134,733	431,172	12,537.6676
民國 104年度 FY 2015	573,824	135,345	438,479	12,558.1356
民國 105年度 FY 2016	581,886	132,543	449,343	12,028.2684
民國 106年度 FY 2017	593,911	136,259	457,652	12,589.4419
民國 107年度 FY 2018	602,180	136,144	466,036	12,106.1619
民國 108年度 FY 2019	614,950	139,652	475,298	12,622.1237
民國 109年度 FY 2020	622,870	140,394	482,476	12,625.4970
民國 110年度 FY 2021	630,386	143,236	487,150	12,634.7499
騎樓地全免 Exemption for Hallway Land	100	-	100	0.0607
騎樓地減免 Reduction for Hallway Land	85,192	54	85,138	5.5113
巷道用地全免 Exemption for Alley Land	327,830	81,849	245,981	2,499.4639
巷道用地減免 Reduction for Alley Land	-	-	-	-
一般用地全免 Exemption for Regular Land	96,637	60,646	35,991	10,025.6783
一般用地減免 Reduction for Regular Land	120,627	687	119,940	104.0355

Table 3-1 Sources of Land Value Tax (Cont.1 End)
B. Broadview for the Reduction or Exemption of Land

Unit : Plot; Hectare; NT\$1,000

Urban Land and Non-Urban Land				
Area		地價 Land Value		
公有 Public	私有 Private	合計 Total	公有 Public	私有 Private
8,060.2429	793.1362	2,891,404,128	2,645,541,380	245,862,748
11,364.4466	950.1886	3,433,543,761	3,157,101,908	276,441,853
11,568.5072	969.1604	3,440,695,155	3,162,358,095	278,337,060
11,583.8167	974.3189	3,446,461,675	3,165,334,084	281,127,591
11,024.0007	1,004.2677	4,395,997,237	4,021,414,411	374,582,826
11,591.2793	998.1625	4,450,948,583	4,080,464,040	370,484,543
11,183.5104	922.6514	4,133,182,886	3,785,108,911	348,073,975
11,708.8076	913.3161	4,185,198,831	3,841,100,229	344,098,602
11,701.3430	924.1539	4,247,135,901	3,890,901,519	356,234,382
11,692.6047	942.1452	4,251,308,257	3,910,361,751	340,946,505
-	0.0607	85,338	-	85,338
0.0202	5.4911	6,554,185	26,425	6,527,760
2,203.2956	296.1683	2,199,987,936	2,057,852,578	142,135,358
-	-	-	-	-
9,466.7357	558.9426	2,006,423,576	1,843,779,661	162,643,915
22.5532	81.4823	38,257,221	8,703,087	29,554,134

表 3-2 土地增值稅稅源

一、按稅率別分

單位：筆；公頃；新臺幣千元

會計年度及稅率別 Fiscal Year & Tax Rate		筆數 Plots	面積 Area	移轉現值 總額 Present Value of Transfer	按物價指數調整 後原地價總額 Original Declared Value After Adjustment	改良土地 費用 Land Improvement Cost	土地漲價 總數額 Gross Amount of Land Value Increment
民國101年度	FY 2012	102,169	334.1813	321,992,197	193,999,469	261,858	127,730,870
民國102年度	FY 2013	105,050	324.0251	353,553,228	200,038,953	335,014	157,067,733
民國103年度	FY 2014	96,178	301.5794	325,747,728	167,132,088	1,607,913	159,997,437
民國104年度	FY 2015	88,557	286.3694	387,856,294	203,230,575	345,072	186,858,703
民國105年度	FY 2016	65,045	236.5065	279,654,799	133,872,812	146,513	147,350,302
民國106年度	FY 2017	71,049	198.6735	281,709,632	151,960,124	1,461,131	131,041,097
民國107年度	FY 2018	79,637	198.1483	303,567,449	167,427,420	464,050	138,580,833
民國108年度	FY 2019	87,090	247.8133	409,955,163	242,888,756	291,287	195,076,696
民國109年度	FY 2020	98,260	239.1293	376,233,050	210,255,632	2,515,961	167,536,490
民國110年度	FY 2021	93,339	235.6215	373,198,679	215,277,211	127,463	163,238,514
應稅地 Total of Taxable Land		59,405	92.6766	248,951,044	141,678,295	122,280	107,150,756
自用住宅用地 Self-use Residence Land		11,169	22.4499	62,396,628	26,684,549	5,983	35,706,096
一般用地 Regular Land		48,236	70.2267	186,554,416	114,993,746	116,297	71,444,660
稅率20% 20% Tax Rate		36,153	48.2237	123,935,408	96,151,042	-	27,784,653
稅率30% 30% Tax Rate		5,671	8.8939	35,209,875	15,688,073	80	19,521,722
稅率40% 40% Tax Rate		6,389	13.1091	27,409,133	3,154,631	116,217	24,138,285
其他 Other		23	-	-	-	-	-
免稅地 Total of Exempt Land		33,934	142.9449	124,247,635	73,598,915	5,183	56,087,758
公有土地 Public Land		1,864	3.8898	27,231,591	2,090,657	-	25,142,973
私有土地 Private Land		32,070	139.0551	97,016,044	71,508,259	5,183	30,944,785
無漲價數 No Increment of Land Value		17,153	52.8440	46,705,987	50,910,904	2,202	508
依法免徵 Tax-Exempt by Land Tax Act		14,917	86.2111	50,310,056	20,597,355	2,981	30,944,277

資料來源：依據本處財產稅科報表20903-02-04編製，103年度以前表號為2613-02-05。

說明：①102年起含免稅地相關資料。

Table 3-2 Sources of Land Value Increment Tax

A. By Tax Rate

Unit : Plot ; Hectare ; NT\$1,000

長期持有 減徵 Reduction for Land Held in Longterm	查定稅額① Assessment Tax	減徵或抵繳 Reduction or Pay Off ①				應納稅額 Tax Payable
		增繳地價稅 Supplemental Payment of Land Value Tax	重劃減徵 Reduction for Consolidation	都更減徵 Urban Renewal Reduction	其他減徵② Other Reduction	
-	17,406,309	705,764	546,764	-	3,711	16,150,070
-	38,289,539	817,989	441,415	-	242	20,368,311
-	38,641,701	949,642	1,378,848	-	769	20,962,675
4,231,131	43,430,844	1,086,187	893,653	-	0	25,848,413
3,573,886	34,705,263	899,960	452,971	-	-	19,311,984
3,024,892	29,631,748	797,583	279,226	-	-	16,097,535
3,728,587	32,031,477	904,214	649,739	-	-	16,343,859
4,793,189	49,032,737	1,030,660	512,135	-	453,105	18,263,538
4,835,284	39,074,951	1,108,539	433,631	-	526,601	19,592,181
4,224,510	37,740,552	1,081,535	235,919	406,509	204,183	19,220,704
1,366,733	20,757,853	968,501	225,359	150,181	193,046	19,220,704
-	3,570,444	177,162	17,779	17,248	1,369	3,356,886
1,366,733	17,187,409	791,339	207,580	132,933	191,677	15,863,818
-	5,556,916	247,745	918	15,278	18,922	5,273,994
31,744	4,255,965	206,893	532	22,125	48,905	3,977,509
1,334,989	7,373,936	336,701	206,130	95,530	123,851	6,611,723
-	591	-	-	-	-	591
2,857,777	16,982,699	113,034	10,560	256,328	11,137	-
1,433,933	8,036,564	9,882	-	254,176	-	-
1,423,844	8,946,135	103,152	10,560	2,152	11,137	-
0	97	2	0	1	-	-
1,423,844	8,946,038	103,150	10,560	2,151	11,137	-

說明：②其他減徵包括徵收減徵。

表 3-2 土地增值稅稅源 (續1)

二、按移轉原因別分

單位：筆；公頃；新臺幣千元

原因別 Transfer Reason	筆數 Plots	面積 Area	移轉現值 總額 Present Value of Transfer	按物價指數調整 後原地價總額 Original Declared Value After Adjustment	改良土地 費用 Land Improvement Cost	土地漲價 總數額 Gross Amount of Land Value Increment
合計 Total	93,339	235.6215	373,198,679	215,277,211	127,463	163,238,514
合併 Merger	-	-	-	-	-	-
買賣 Sale	64,001	118.2857	265,427,668	173,321,947	112,443	95,496,636
贈與 Gift	8,791	13.9800	15,075,958	8,944,548	5,906	6,295,024
交換 Exchange	670	1.3847	3,201,610	1,723,011	-	1,505,227
典權 Pledge	-	-	-	-	-	-
分割 Partition	19	-	12,159	8,979	-	3,328
法院拍賣 Court Auction	1,468	8.9463	5,381,023	4,393,320	6,133	1,479,056
照價收買 Purchase on the Assesed Present Value	-	-	-	-	-	-
公有移轉 Transfer of Public Land	1,862	3.8863	27,227,181	2,090,441	-	25,138,778
政府受贈 Donation for Government	298	1.2464	4,327,857	1,235,670	-	3,118,813
政府贈與 Donation by Government	2	0.0035	4,410	215	-	4,195
配偶贈與 Matrimonial Donation	3,568	9.9888	18,144,208	7,966,616	852	10,247,846
社福受贈 Donation for Social Welfare Groups	-	-	-	-	-	-
領抵價地 Compensated Land	-	-	-	-	-	-
農地買賣 Sale of Agriculture Land	423	15.5478	1,364,331	1,241,817	-	285,360
農地贈與 Agriculture Land Donation	543	27.3317	1,777,079	1,451,936	-	539,370
農地交換 Exchange of Agriculture Land	5	0.3005	10,218	12,504	-	-
農地分割 Agriculture Land by Separate	1	0.1280	25,223	24,390	-	833
農地法拍 Agriculture Land by Court Auction	1	0.0847	994	2,885	-	-
最低稅率 Min. Tax Rate	-	-	-	-	-	-
追繳稅款 Retrieves for Tax Payment	34	0.0544	120,216	66,116	-	54,100
一般重購 General Reacquisition	99	0.1314	323,284	220,918	-	102,366
遺贈 Bequest	174	0.4297	1,054,555	1,056,648	-	-
分期繳納 Payment by Installments	-	-	-	-	-	-
記存 Reserved	53	1.1885	2,369,215	1,358,118	-	1,011,097

Table 3-2 Sources of Land Value Increment Tax (Cont.1)

B. By Transfer Reason

Unit : Plot ; Hectare ; NT\$1,000

長期持有 減徵 Reduction for Land Held in Longterm	查定稅額① Assessment Tax	減徵或抵繳 Reduction or Pay Off ①				應納稅額 Tax Payable
		增繳地價稅 Supplemental Payment of Land Value Tax	重劃減徵 Reduction for Consolidation	都更減徵 Urban Renewal Reduction	其他減徵② Other Reduction	
4,224,510	37,740,552	1,081,535	235,919	406,509	204,183	19,220,704
-	-	-	-	-	-	-
1,053,610	17,837,088	827,520	180,975	100,556	93,834	16,634,120
208,576	1,643,624	80,490	28,662	9,118	4,231	1,521,113
30,262	389,039	18,123	-	21,113	55,662	294,140
-	-	-	-	-	-	-
0	883	33	-	-	-	850
31,991	336,904	16,534	15,085	-	6,199	299,083
-	-	-	-	-	-	-
1,433,624	8,035,261	9,882	-	254,176	-	-
67,144	926,732	22,118	-	-	-	-
310	1,304	-	-	-	-	-
395,737	2,807,270	61,607	2,786	2,151	1,197	-
-	-	-	-	-	-	-
-	-	-	-	-	-	-
10,604	77,596	0	-	-	-	-
33,275	163,866	27	-	-	-	-
-	-	-	-	-	-	-
-	167	-	-	-	-	-
-	-	-	-	-	-	-
-	-	-	-	-	-	-
-	5,249	233	-	-	-	5,016
47	20,708	767	-	82	-	19,859
-	-	-	-	-	-	-
-	-	-	-	-	-	-
76	204,361	9,396	-	-	-	194,965

表 3-2 土地增值稅稅源 (續2完)

二、按移轉原因別分 (續1完)

單位：筆；公頃；新臺幣千元

原因別 Transfer Reason	筆數 Plots	面積 Area	移轉現值 總額 Present Value of Transfer	按物價指數調整 後原地價總額 Original Declared Value After Adjustment	改良土地 費用 Land Improvement Cost	土地漲價 總數額 Gross Amount of Land Value Increment
抵繳稅款 Deduction for Tax Collections	71	0.2610	75,474	76,300	-	-
水源減徵 20% 20% Reduction for Water Source	-	-	-	-	-	-
水源減徵 30% 30% Reduction for Water Source	-	-	-	-	-	-
水源減徵 50% 50% Reduction for Water Source	-	-	-	-	-	-
水源免稅 Tax-Exempt for Water Source	-	-	-	-	-	-
信託取得 Trust Acquisition	-	-	-	-	-	-
判決移轉 Transfer by Adjudication	897	0.6053	1,633,857	1,000,015	-	639,642
判決分割 Partition by Adjudication	89	-	139,595	83,618	-	57,961
私校受贈 Donation for Private School	2	0.0086	34,931	17,288	-	17,644
徵收全免 Tax-free from Acquisition	-	-	-	-	-	-
協議價購 Purchase with the Agreed Price	1,031	2.2206	1,133,790	1,013,707	-	673,177
農地合併 Farmland Amalgamation	-	-	-	-	-	-
都市公保 Urban Land Reserved for Public Facilities	7,989	19.2681	19,008,548	5,811,975	700	13,378,615
非都公設 Non-Urban Land Reserved for Public Facilities	-	-	-	-	-	-
信託移轉 Trust Transfer	-	-	-	-	-	-
金融合併 Financial Merger	-	-	-	-	-	-
贖財不課 No Leving Tax for Surplus Property	457	2.1798	1,782,877	511,494	1,429	1,276,025
都市更新 Urban Renewal	166	0.0657	196,165	103,399	-	92,932
都更減徵 Urban Renewal Reduction	180	0.2314	768,692	326,113	-	442,579
一般贖財 General Surplus Property	-	-	-	-	-	-
信託歸屬 Trust Devolved	9	0.0093	29,437	9,436	-	20,075
都更記存 Reserved Urban Renewal	3	0.0130	44,288	113	-	44,176
視為農地 Deemed as Agricultural Land	261	7.5826	1,760,949	684,567	-	1,084,235
原有不課 Original Non-taxable	172	0.2576	742,886	519,108	-	229,426
水利不課 Water Conservancy Non-taxable	-	-	-	-	-	-
其他 Others	-	-	-	-	-	-

Table 3-2 Sources of Land Value Increment Tax (Cont.2 End)

B. By Transfer Reason (Cont.1 End)

Unit : Plot ; Hectare ; NT\$1,000

長期持有 減徵 Reduction for Land Held in Longterm	查定稅額① Assessment Tax	減徵或抵繳 Reduction or Pay Off ①				應納稅額 Tax Payable
		增繳地價稅 Supplemental Payment of Land Value Tax	重劃減徵 Reduction for Consolidation	都更減徵 Urban Renewal Reduction	其他減徵② Other Reduction	
-	-	-	-	-	-	-
-	-	-	-	-	-	-
-	-	-	-	-	-	-
-	-	-	-	-	-	-
-	-	-	-	-	-	-
19,818	168,182	8,214	-	-	-	159,967
1,627	15,503	735	-	-	-	14,711
657	5,063	253	-	-	-	-
-	-	-	-	-	-	-
35,525	194,059	3,723	-	-	-	-
-	-	-	-	-	-	-
748,987	4,003,370	5,023	-	-	-	-
-	-	-	-	-	-	-
-	-	-	-	-	-	-
-	-	-	-	-	-	-
59,420	362,700	7,506	1,370	-	3,624	-
4,177	25,562	375	-	-	-	-
16,476	116,331	5,456	637	13,667	32,229	64,343
-	-	-	-	-	-	-
729	5,961	297	-	-	891	4,773
3,521	14,116	706	-	5,646	-	7,764
65,554	325,905	-	6,403	-	-	-
2,765	53,748	2,519	-	-	6,316	-
-	-	-	-	-	-	-
-	-	-	-	-	-	-

表 3-3 房屋稅稅源

單位：件、平方公尺、新臺幣千元

期底及使用別 End of June & Usage		合計 Grand Total		
		件數 No. of Cases	面積 Area	現值 Value
民國101年6月底	2012	1,097,581	180,692,750	832,912,306
民國102年6月底	2013	1,105,979	184,555,387	846,250,956
民國103年6月底	2014	1,112,554	187,129,628	860,003,225
民國104年6月底	2015	1,144,671	194,102,485	967,614,468
民國105年6月底	2016	1,151,272	196,212,276	1,008,671,546
民國106年6月底	2017	1,160,099	Ⓔ198,661,299	Ⓔ1,052,170,182
民國107年6月底	2018	1,177,773	200,725,288	995,341,415
民國108年6月底	2019	1,186,669	203,598,164	1,031,376,580
民國109年6月底	2020	1,195,159	206,177,794	1,083,031,220
民國110年6月底	2021	1,203,095	208,135,298	1,111,315,827
應稅房屋 Taxable House		1,000,855	139,611,115	832,669,708
住家用 Residential Purposes		783,605	83,915,489	426,760,672
自住或公益出租用 Residential Purposes by Owner or Leased for Public Welfare Purposes		691,976	73,794,663	342,883,469
非住家用 Residential Purposes Not by Owner		91,629	10,120,826	83,877,202
非住家用 Non-Residential Purposes		217,250	55,695,626	405,909,036
營業用 Business		162,210	36,243,275	276,288,210
私人醫院、診所或自由職業事務所用 Private Hospital, Clinic, or Professional Office		6,322	1,439,110	8,851,939
非住家非營業用 Non-Residential & Non-Business		48,718	18,013,241	120,768,888
免稅房屋 Exempt House		202,240	68,524,183	278,646,119

資料來源：依據本處財產稅科報表20903-02-07編製，103年度以前表號為2613-02-08。

Table 3-3 Sources of House Tax

Unit : Case; Square of Meter; NT\$1,000

公有 Public			私有 Private		
件數 No. of Cases	面積 Area	現值 Value	件數 No. of Cases	面積 Area	現值 Value
25,604	23,768,422	101,179,846	1,071,977	156,924,328	731,732,460
25,082	24,155,256	102,135,487	1,080,897	160,400,131	744,115,469
22,095	24,565,303	103,075,967	1,090,459	162,564,325	756,927,258
23,165	25,083,249	104,999,438	1,121,506	169,019,236	862,615,030
23,043	25,770,665	113,535,160	1,128,229	170,441,611	895,136,387
22,958	25,931,035	114,339,119	1,137,141	Ⓒ172,730,264	Ⓒ 937,831,063
22,951	26,221,622	114,302,970	1,154,822	174,503,666	881,038,446
22,988	26,705,919	119,788,212	1,163,681	176,892,244	911,588,368
23,746	27,235,305	126,440,210	1,171,413	178,942,490	956,591,010
24,188	28,731,235	139,488,053	1,178,907	179,404,063	971,827,773
6,417	5,660,531	32,547,261	994,438	133,950,584	800,122,447
3,851	398,472	1,793,686	779,754	83,517,017	424,966,985
317	35,846	133,662	691,659	73,758,817	342,749,808
3,534	362,627	1,660,025	88,095	9,758,199	82,217,178
2,566	5,262,059	30,753,575	214,684	50,433,567	375,155,462
1,689	2,194,950	18,785,891	160,521	34,048,324	257,502,319
40	19,474	132,578	6,282	1,419,636	8,719,361
837	3,047,634	11,835,107	47,881	14,965,607	108,933,781
17,771	23,070,704	106,940,792	184,469	45,453,479	171,705,327

表 3-3 房屋稅稅源 (續1)

單位：件、平方公尺、新臺幣千元

房屋構造及使用別 House Structure & Usage	合計 Total		
	件數 No. of Cases	面積 Area	現值 Value
	鋼骨混凝土造 Ferroconcrete	3,006	2,688,408
應稅房屋Taxable House	2,826	1,859,958	21,666,604
住家用 Residential Purposes	563	114,380	2,700,609
自住或公益出租用 Residential Purposes by Owner or Leased for Public Welfare Purposes	351	66,769	1,881,617
非自住用 Residential Purposes Not by Owner	212	47,611	818,992
非住家用 Non-Residential Purposes	2,263	1,745,578	18,965,995
營業用 Business	1,796	1,268,077	14,911,571
私人醫院、診所或自由職業事務所用 Private Hospital, Clinic, or Professional Office	40	18,634	186,995
非住家非營業用 Non-Residential & Non-Business	427	458,867	3,867,429
免稅房屋Exempt House	180	828,450	5,851,761
鋼骨造 Steel-Backbone	20,542	15,769,608	240,019,754
應稅房屋Taxable House	19,740	10,924,464	198,981,103
住家用 Residential Purposes	10,230	1,938,668	67,864,500
自住或公益出租用 Residential Purposes by Owner or Leased for Public Welfare Purposes	6,859	1,228,096	36,693,779
非自住用 Residential Purposes Not by Owner	3,371	710,572	31,170,722
非住家用 Non-Residential Purposes	9,510	8,985,797	131,116,603
營業用 Business	5,932	5,528,013	89,201,560
私人醫院、診所或自由職業事務所用 Private Hospital, Clinic, or Professional Office	152	68,493	1,450,055
非住家非營業用 Non-Residential & Non-Business	3,426	3,389,291	40,464,987
免稅房屋Exempt House	802	4,845,143	41,038,651
鋼骨鋼筋混凝土造 Steel Bar & Ferroconcrete	21,267	11,435,306	135,520,561
應稅房屋Taxable House	20,045	6,726,170	98,809,703
住家用 Residential Purposes	13,759	2,255,216	48,907,765
自住或公益出租用 Residential Purposes by Owner or Leased for Public Welfare Purposes	11,369	1,784,283	35,750,673
非自住用 Residential Purposes Not by Owner	2,390	470,933	13,157,092
非住家用 Non-Residential Purposes	6,286	4,470,954	49,901,938
營業用 Business	3,873	2,624,504	33,809,813
私人醫院、診所或自由職業事務所用 Private Hospital, Clinic, or Professional Office	109	27,547	298,686
非住家非營業用 Non-Residential & Non-Business	2,304	1,818,904	15,793,438
免稅房屋Exempt House	1,222	4,709,136	36,710,858

Table 3-3 Sources of House Tax (Cont.1)

Unit : Case; Square of Meter; NT\$1,000

公有 Public			私有 Private		
件數 No. of Cases	面積 Area	現值 Value	件數 No. of Cases	面積 Area	現值 Value
112	653,879	5,163,741	2,894	2,034,529	22,354,623
15	122,261	947,853	2,811	1,737,697	20,718,751
1	30	76	562	114,351	2,700,533
-	-	-	351	66,769	1,881,617
1	30	76	211	47,582	818,917
14	122,231	947,777	2,249	1,623,346	18,018,217
7	75,020	697,200	1,789	1,193,057	14,214,370
-	-	-	40	18,634	186,995
7	47,212	250,577	420	411,655	3,616,852
97	531,618	4,215,889	83	296,833	1,635,872
457	2,528,216	23,002,882	20,085	13,241,392	217,016,872
284	662,989	5,233,397	19,456	10,261,475	193,747,706
52	5,907	66,934	10,178	1,932,761	67,797,567
1	2,118	14,944	6,858	1,225,978	36,678,835
51	3,790	51,990	3,320	706,783	31,118,732
232	657,082	5,166,463	9,278	8,328,715	125,950,140
181	326,928	2,905,827	5,751	5,201,084	86,295,733
5	1,348	10,627	147	67,146	1,439,428
46	328,806	2,250,009	3,380	3,060,485	38,214,979
173	1,865,227	17,769,485	629	2,979,917	23,269,165
339	2,723,372	23,878,795	20,928	8,711,935	111,641,766
126	1,024,395	9,268,912	19,919	5,701,775	89,540,791
5	2,449	24,923	13,754	2,252,767	48,882,842
-	213	823	11,369	1,784,070	35,749,850
5	2,236	24,100	2,385	468,697	13,132,992
121	1,021,947	9,243,988	6,165	3,449,008	40,657,950
66	554,910	7,393,157	3,807	2,069,594	26,416,657
2	1,472	16,781	107	26,075	281,905
53	465,565	1,834,051	2,251	1,353,339	13,959,388
213	1,698,976	14,609,883	1,009	3,010,160	22,100,975

表 3-3 房屋稅稅源 (續2)

單位：件、平方公尺、新臺幣千元

房屋構造及使用別 House Structure & Usage	合計 Total		
	件數 No. of Cases	面積 Area	現值 Value
	鋼筋混凝土造 Steel Bar Concrete	1,001,033	160,410,061
應稅房屋Taxable House	882,897	109,603,018	499,891,057
住家用 Residential Purposes	711,871	73,058,856	299,375,850
自住或公益出租用 Residential Purposes by Owner or Leased for Public Welfare Purposes	635,537	65,399,334	262,198,615
非自住用 Residential Purposes Not by Owner	76,334	7,659,522	37,177,235
非住家用 Non-Residential Purposes	171,026	36,544,162	200,515,208
營業用 Business	125,622	23,476,045	133,799,662
私人醫院、診所或自由職業事務所用 Private Hospital, Clinic, or Professional Office	5,423	1,249,634	6,819,229
非住家非營業用 Non-Residential & Non-Business	39,981	11,818,483	59,896,317
免稅房屋Exempt House	118,136	50,807,043	188,035,659
加強磚造 Strengthened Brick	109,523	12,651,742	15,082,454
應稅房屋Taxable House	58,601	7,737,089	10,020,995
住家用 Residential Purposes	39,272	5,280,744	6,564,554
自住或公益出租用 Residential Purposes by Owner or Leased for Public Welfare Purposes	31,808	4,288,879	5,291,154
非自住用 Residential Purposes Not by Owner	7,464	991,864	1,273,401
非住家用 Non-Residential Purposes	19,329	2,456,345	3,456,440
營業用 Business	17,404	2,113,092	2,985,457
私人醫院、診所或自由職業事務所用 Private Hospital, Clinic, or Professional Office	536	70,110	91,241
非住家非營業用 Non-Residential & Non-Business	1,389	273,143	379,742
免稅房屋Exempt House	50,922	4,914,653	5,061,459
預鑄混凝土造 Prefabricated Concrete	7	99,144	319,400
應稅房屋Taxable House	7	98,203	317,728
住家用 Residential Purposes	2	273	572
自住或公益出租用 Residential Purposes by Owner or Leased for Public Welfare Purposes	2	175	264
非自住用 Residential Purposes Not by Owner	-	98	308
非住家用 Non-Residential Purposes	5	97,930	317,156
營業用 Business	5	58,133	247,068
私人醫院、診所或自由職業事務所用 Private Hospital, Clinic, or Professional Office	-	-	-
非住家非營業用 Non-Residential & Non-Business	-	39,797	70,088
免稅房屋Exempt House	-	941	1,673

Table 3-3 Sources of House Tax (Cont.2)

Unit : Case; Square of Meter; NT\$1,000

公有 Public			私有 Private		
件數 No. of Cases	面積 Area	現值 Value	件數 No. of Cases	面積 Area	現值 Value
16,968	21,464,117	85,801,382	984,065	138,945,943	602,125,334
5,462	3,743,481	16,951,992	877,435	105,859,537	482,939,065
3,584	376,283	1,685,318	708,287	72,682,573	297,690,532
315	33,504	117,883	635,222	65,365,829	262,080,732
3,269	342,778	1,567,435	73,065	7,316,744	35,609,800
1,878	3,367,198	15,266,675	169,148	33,176,963	185,248,533
1,183	1,166,626	7,686,861	124,439	22,309,419	126,112,800
30	16,358	104,891	5,393	1,233,276	6,714,338
665	2,184,214	7,474,922	39,316	9,634,268	52,421,395
11,506	17,720,636	68,849,390	106,630	33,086,407	119,186,269
1,966	698,617	955,053	107,557	11,953,125	14,127,401
266	48,817	74,006	58,335	7,688,272	9,946,988
117	7,181	9,003	39,155	5,273,563	6,555,552
1	11	11	31,807	4,288,869	5,291,142
116	7,170	8,992	7,348	984,694	1,264,409
149	41,636	65,004	19,180	2,414,709	3,391,437
109	30,742	52,317	17,295	2,082,349	2,933,140
-	-	-	536	70,110	91,241
40	10,894	12,687	1,349	262,249	367,056
1,700	649,800	881,047	49,222	4,264,853	4,180,412
-	-	-	7	99,144	319,400
-	-	-	7	98,203	317,728
-	-	-	2	273	572
-	-	-	2	175	264
-	-	-	-	98	308
-	-	-	5	97,930	317,156
-	-	-	5	58,133	247,068
-	-	-	-	-	-
-	-	-	-	39,797	70,088
-	-	-	-	941	1,673

表 3-3 房屋稅稅源 (續3)

單位：件、平方公尺、新臺幣千元

房屋構造及使用別 House Structure & Usage	合計 Total		
	件數 No. of Cases	面積 Area	現值 Value
	础砧石造 Lo-Ko Stone	430	24,613
應稅房屋Taxable House	103	6,449	5,248
住家用 Residential Purposes	19	1,993	1,723
自住或公益出租用 Residential Purposes by Owner or Leased for Public Welfare Purposes	14	1,404	1,368
非自住用 Residential Purposes Not by Owner	5	590	354
非住家用 Non-Residential Purposes	84	4,456	3,525
營業用 Business	76	3,589	2,899
私人醫院、診所或自由職業事務所用 Private Hospital, Clinic, or Professional Office	-	-	-
非住家非營業用 Non-Residential & Non-Business	8	866	626
免稅房屋Exempt House	327	18,164	9,950
鋼鐵造(未達200平方公尺) Metal(below 200m²)	7,549	1,087,609	1,254,388
應稅房屋Taxable House	4,787	750,019	896,982
住家用 Residential Purposes	2,749	382,326	509,387
自住或公益出租用 Residential Purposes by Owner or Leased for Public Welfare Purposes	2,275	319,519	424,880
非自住用 Residential Purposes Not by Owner	474	62,807	84,508
非住家用 Non-Residential Purposes	2,038	367,693	387,595
營業用 Business	1,584	301,478	305,037
私人醫院、診所或自由職業事務所用 Private Hospital, Clinic, or Professional Office	9	1,154	1,256
非住家非營業用 Non-Residential & Non-Business	445	65,061	81,301
免稅房屋Exempt House	2,762	337,590	357,406
鋼鐵造(200平方公尺以上) Metal(above 200m²)	1,065	694,567	1,042,324
應稅房屋Taxable House	975	578,609	823,677
住家用 Residential Purposes	182	61,163	80,866
自住或公益出租用 Residential Purposes by Owner or Leased for Public Welfare Purposes	119	45,539	59,370
非自住用 Residential Purposes Not by Owner	63	15,624	21,496
非住家用 Non-Residential Purposes	793	517,445	742,812
營業用 Business	696	456,669	619,835
私人醫院、診所或自由職業事務所用 Private Hospital, Clinic, or Professional Office	-	-	-
非住家非營業用 Non-Residential & Non-Business	97	60,776	122,976
免稅房屋Exempt House	90	115,958	218,647

Table 3-3 Sources of House Tax (Cont.3)

Unit : Case; Square of Meter; NT\$1,000

公有 Public			私有 Private		
件數 No. of Cases	面積 Area	現值 Value	件數 No. of Cases	面積 Area	現值 Value
20	1,231	728	410	23,382	14,470
-	-	-	103	6,449	5,248
-	-	-	19	1,993	1,723
-	-	-	14	1,404	1,368
-	-	-	5	590	354
-	-	-	84	4,456	3,525
-	-	-	76	3,589	2,899
-	-	-	-	-	-
-	-	-	8	866	626
20	1,231	728	307	16,933	9,222
173	38,596	56,496	7,376	1,049,014	1,197,892
27	10,434	14,742	4,760	739,585	882,240
3	479	729	2,746	381,847	508,658
-	-	-	2,275	319,519	424,880
3	479	729	471	62,328	83,779
24	9,955	14,013	2,014	357,738	373,581
19	9,587	13,749	1,565	291,891	291,288
1	129	134	8	1,025	1,122
4	239	130	441	64,822	81,171
146	28,162	41,754	2,616	309,428	315,652
72	106,816	197,114	993	587,751	845,210
14	21,978	27,287	961	556,631	796,390
1	213	266	181	60,950	80,600
-	-	-	119	45,539	59,370
1	213	266	62	15,411	21,230
13	21,765	27,021	780	495,681	715,791
11	16,251	22,605	685	440,418	597,230
-	-	-	-	-	-
2	5,513	4,416	95	55,263	118,561
58	84,838	169,827	32	31,120	48,819

表 3-3 房屋稅稅源 (續4)

單位：件、平方公尺、新臺幣千元

房屋構造及使用別 House Structure & Usage	合計 Total		
	件數 No. of Cases	面積 Area	現值 Value
	雜木以外 Mixed Wood	3,366	257,928
應稅房屋 Taxable House	722	67,220	65,956
住家用 Residential Purposes	150	20,671	21,261
自住或公益出租用 Residential Purposes by Owner or Leased for Public Welfare Purposes	78	10,138	10,907
非自住用 Residential Purposes Not by Owner	72	10,533	10,353
非住家用 Non-Residential Purposes	572	46,549	44,695
營業用 Business	515	39,982	38,113
私人醫院、診所或自由職業事務所用 Private Hospital, Clinic, or Professional Office	3	228	135
非住家非營業用 Non-Residential & Non-Business	54	6,339	6,447
免稅房屋 Exempt House	2,644	190,708	131,716
雜木 Wood	4,860	271,687	147,535
應稅房屋 Taxable House	719	53,993	34,714
住家用 Residential Purposes	85	15,064	12,036
自住或公益出租用 Residential Purposes by Owner or Leased for Public Welfare Purposes	50	7,935	7,105
非自住用 Residential Purposes Not by Owner	35	7,130	4,931
非住家用 Non-Residential Purposes	634	38,929	22,678
營業用 Business	576	29,972	18,125
私人醫院、診所或自由職業事務所用 Private Hospital, Clinic, or Professional Office	4	234	168
非住家非營業用 Non-Residential & Non-Business	54	8,723	4,385
免稅房屋 Exempt House	4,141	217,693	112,821
卵石混凝土造 Concrete & Pebble	60	7,411	5,425
應稅房屋 Taxable House	20	3,923	3,138
住家用 Residential Purposes	16	3,071	2,511
自住或公益出租用 Residential Purposes by Owner or Leased for Public Welfare Purposes	5	1,246	985
非自住用 Residential Purposes Not by Owner	11	1,826	1,527
非住家用 Non-Residential Purposes	4	852	626
營業用 Business	1	227	124
私人醫院、診所或自由職業事務所用 Private Hospital, Clinic, or Professional Office	-	-	-
非住家非營業用 Non-Residential & Non-Business	3	625	502
免稅房屋 Exempt House	40	3,487	2,288

Table 3-3 Sources of House Tax (Cont.4)

Unit : Case; Square of Meter; NT\$1,000

公有 Public			私有 Private		
件數 No. of Cases	面積 Area	現值 Value	件數 No. of Cases	面積 Area	現值 Value
785	84,790	64,437	2,581	173,137	133,235
38	3,732	3,550	684	63,488	62,406
11	784	540	139	19,887	20,720
-	-	-	78	10,138	10,907
11	784	540	61	9,750	9,813
27	2,948	3,009	545	43,601	41,686
23	2,611	2,404	492	37,371	35,709
1	29	17	2	199	118
3	308	589	51	6,031	5,858
747	81,059	60,888	1,897	109,649	70,829
1,221	84,548	45,134	3,639	187,139	102,401
46	4,294	2,577	673	49,699	32,137
17	1,256	657	68	13,808	11,379
-	-	-	50	7,935	7,105
17	1,256	657	18	5,873	4,273
29	3,038	1,920	605	35,891	20,758
27	2,773	1,786	549	27,199	16,339
-	-	-	4	234	168
2	264	134	52	8,458	4,252
1,175	80,254	42,557	2,966	137,439	70,264
1	136	58	59	7,275	5,368
1	136	58	19	3,787	3,080
1	136	58	15	2,935	2,454
-	-	-	5	1,246	985
1	136	58	10	1,690	1,469
-	-	-	4	852	626
-	-	-	1	227	124
-	-	-	-	-	-
-	-	-	3	625	502
-	-	-	40	3,487	2,288

表 3-3 房屋稅稅源 (續5)

單位：件、平方公尺、新臺幣千元

房屋構造及使用別 House Structure & Usage	合計 Total		
	件數 No. of Cases	面積 Area	現值 Value
	磚石造 Brick	28,836	2,642,076
應稅房屋 Taxable House	9,394	1,197,811	1,151,566
住家用 Residential Purposes	4,703	781,700	718,068
自住或公益出租用 Residential Purposes by Owner or Leased for Public Welfare Purposes	3,507	640,582	562,136
非自住用 Residential Purposes Not by Owner	1,196	141,118	155,932
非住家用 Non-Residential Purposes	4,691	416,111	433,498
營業用 Business	4,116	340,800	348,753
私人醫院、診所或自由職業事務所用 Private Hospital, Clinic, or Professional Office	46	3,076	4,172
非住家非營業用 Non-Residential & Non-Business	529	72,235	80,573
免稅房屋 Exempt House	19,442	1,444,265	1,108,638
土磚混合造 Earth & Brick	137	8,011	1,157
應稅房屋 Taxable House	4	753	521
住家用 Residential Purposes	1	568	503
自住或公益出租用 Residential Purposes by Owner or Leased for Public Welfare Purposes	1	568	503
非自住用 Residential Purposes Not by Owner	-	-	-
非住家用 Non-Residential Purposes	3	186	18
營業用 Business	3	186	18
私人醫院、診所或自由職業事務所用 Private Hospital, Clinic, or Professional Office	-	-	-
非住家非營業用 Non-Residential & Non-Business	-	-	-
免稅房屋 Exempt House	133	7,258	636
竹造 Bamboo	188	7,944	522
應稅房屋 Taxable House	8	2,067	189
住家用 Residential Purposes	-	-	-
自住或公益出租用 Residential Purposes by Owner or Leased for Public Welfare Purposes	-	-	-
非自住用 Residential Purposes Not by Owner	-	-	-
非住家用 Non-Residential Purposes	8	2,067	189
營業用 Business	7	1,937	114
私人醫院、診所或自由職業事務所用 Private Hospital, Clinic, or Professional Office	-	-	-
非住家非營業用 Non-Residential & Non-Business	1	130	75
免稅房屋 Exempt House	180	5,878	333

Table 3-3 Sources of House Tax (Cont.5)

Unit : Case; Square of Meter; NT\$1,000

公有 Public			私有 Private		
件數 No. of Cases	面積 Area	現值 Value	件數 No. of Cases	面積 Area	現值 Value
2,052	346,031	322,201	26,784	2,296,045	1,938,003
138	18,014	22,888	9,256	1,179,797	1,128,678
59	3,756	5,184	4,644	777,944	712,885
-	-	-	3,507	640,582	562,136
59	3,756	5,184	1,137	137,363	150,749
79	14,258	17,705	4,612	401,853	415,793
63	9,502	9,985	4,053	331,298	338,768
1	139	128	45	2,937	4,045
15	4,618	7,593	514	67,617	72,981
1,914	328,018	299,312	17,528	1,116,248	809,326
-	-	-	137	8,011	1,157
-	-	-	4	753	521
-	-	-	1	568	503
-	-	-	1	568	503
-	-	-	-	-	-
-	-	-	3	186	18
-	-	-	3	186	18
-	-	-	-	-	-
-	-	-	-	-	-
-	-	-	133	7,258	636
7	271	11	181	7,674	511
-	-	-	8	2,067	189
-	-	-	-	-	-
-	-	-	-	-	-
-	-	-	-	-	-
-	-	-	8	2,067	189
-	-	-	7	1,937	114
-	-	-	-	-	-
-	-	-	1	130	75
7	271	11	173	5,607	322

表 3-3 房屋稅稅源 (續6)

單位：件、平方公尺、新臺幣千元

房屋構造及使用別 House Structure & Usage	合計 Total		
	件數 No. of Cases	面積 Area	現值 Value
	冷氣機 Air Conditioner	-	-
應稅房屋 Taxable House	-	-	-
住家用 Residential Purposes	-	-	-
自住或公益出租用 Residential Purposes by Owner or Leased for Public Welfare Purposes	-	-	-
非自住用 Residential Purposes Not by Owner	-	-	-
非住家用 Non-Residential Purposes	-	-	-
營業用 Business	-	-	-
私人醫院、診所或自由職業事務所用 Private Hospital, Clinic, or Professional Office	-	-	-
非住家非營業用 Non-Residential & Non-Business	-	-	-
免稅房屋 Exempt House	-	-	-
昇降機 Elevator	-	-	-
應稅房屋 Taxable House	-	-	-
住家用 Residential Purposes	-	-	-
自住或公益出租用 Residential Purposes by Owner or Leased for Public Welfare Purposes	-	-	-
非自住用 Residential Purposes Not by Owner	-	-	-
非住家用 Non-Residential Purposes	-	-	-
營業用 Business	-	-	-
私人醫院、診所或自由職業事務所用 Private Hospital, Clinic, or Professional Office	-	-	-
非住家非營業用 Non-Residential & Non-Business	-	-	-
免稅房屋 Exempt House	-	-	-
純土造 Earth	1,226	79,184	4,153
應稅房屋 Taxable House	7	1,369	530
住家用 Residential Purposes	3	796	468
自住或公益出租用 Residential Purposes by Owner or Leased for Public Welfare Purposes	1	199	115
非自住用 Residential Purposes Not by Owner	2	597	353
非住家用 Non-Residential Purposes	4	573	62
營業用 Business	4	573	62
私人醫院、診所或自由職業事務所用 Private Hospital, Clinic, or Professional Office	-	-	-
非住家非營業用 Non-Residential & Non-Business	-	-	-
免稅房屋 Exempt House	1,219	77,815	3,623

表 3-3 房屋稅稅源 (續7完)

單位：件、平方公尺、新臺幣千元

房屋構造及使用別 House Structure & Usage	合計 Total		
	件數 No. of Cases	面積 Area	現值 Value
充氣屋 Balloon	-	-	-
應稅房屋 Taxable House	-	-	-
住家用 Residential Purposes	-	-	-
自住或公益出租用 Residential Purposes by Owner or Leased for Public Welfare Purposes	-	-	-
非自住用 Residential Purposes Not by Owner	-	-	-
非住家用 Non-Residential Purposes	-	-	-
營業用 Business	-	-	-
私人醫院、診所或自由職業事務所用 Private Hospital, Clinic, or Professional Office	-	-	-
非住家非營業用 Non-Residential & Non-Business	-	-	-
免稅房屋 Exempt House	-	-	-
油槽 Oil Trough	-	-	-
應稅房屋 Taxable House	-	-	-
住家用 Residential Purposes	-	-	-
自住或公益出租用 Residential Purposes by Owner or Leased for Public Welfare Purposes	-	-	-
非自住用 Residential Purposes Not by Owner	-	-	-
非住家用 Non-Residential Purposes	-	-	-
營業用 Business	-	-	-
私人醫院、診所或自由職業事務所用 Private Hospital, Clinic, or Professional Office	-	-	-
非住家非營業用 Non-Residential & Non-Business	-	-	-
免稅房屋 Exempt House	-	-	-
其他 Others	-	-	-
應稅房屋 Taxable House	-	-	-
住家用 Residential Purposes	-	-	-
自住或公益出租用 Residential Purposes by Owner or Leased for Public Welfare Purposes	-	-	-
非自住用 Residential Purposes Not by Owner	-	-	-
非住家用 Non-Residential Purposes	-	-	-
營業用 Business	-	-	-
私人醫院、診所或自由職業事務所用 Private Hospital, Clinic, or Professional Office	-	-	-
非住家非營業用 Non-Residential & Non-Business	-	-	-
免稅房屋 Exempt House	-	-	-

表 3-4 使用牌照稅稅源及稽徵

一、稅源①

單位：輛

會計年度別 Fiscal Year		合計		小客車		大客車	
		Total		Small Passenger Vehicles		Large Passenger Vehicles	
		應稅	免稅	應稅	免稅	應稅	免稅
		Taxable	Exempt	Taxable	Exempt	Taxable	Exempt
民國101年度	FY 2012	828,955	101,315	711,651	93,436	9,199	4,804
民國102年度	FY 2013	686,396	98,523	598,103	91,937	4,398	3,941
民國103年度	FY 2014	690,004	90,855	596,347	85,075	4,465	3,174
民國104年度	FY 2015	730,027	92,254	627,118	86,598	5,018	2,917
民國105年度	FY 2016	740,668	91,509	632,818	86,076	5,004	2,738
民國106年度	FY 2017	752,016	92,089	636,720	86,618	4,756	2,773
民國107年度	FY 2018	759,976	92,479	639,977	86,810	4,630	2,842
民國108年度	FY 2019	762,480	97,205	638,020	91,297	4,505	2,854
民國109年度	FY 2020	766,807	98,777	637,139	92,702	3,841	2,883
民國110年度	FY 2021	776,618	99,818	640,082	93,726	3,460	2,814

資料來源：依據本處機會稅科報表20903-02-10編製稅源，103年度依報表「臺北市使用牌照稅概況-按汽缸總排氣量分」101年度及102年度依報表「機動車輛使用牌照稅稅源統計表」；本處機會稅科報表20903-02-08編製稽徵，103年度以前表號為2613-02-11。

Table 3-4 Sources and Levy of Vehicle License Tax

A. Sources of Vehicle License Tax

Unit : Vehicle

貨車 Trucks		農村拼裝車 Flat-bodied Trucks		曳引車 Tractors		機車 Motorcycles	
應稅 Taxable	免稅 Exempt	應稅 Taxable	免稅 Exempt	應稅 Taxable	免稅 Exempt	應稅 Taxable	免稅 Exempt
94,457	2,872	-	-	-	-	13,648	203
65,763	2,466	-	-	-	-	18,132	179
67,169	2,417	-	-	-	-	22,023	189
69,780	2,537	-	-	-	-	28,111	202
70,022	2,474	-	-	-	-	32,824	221
69,728	2,483	-	-	1,177	-	39,635	215
69,657	2,598	-	-	1,047	-	44,665	229
70,172	2,639	-	-	1,049	-	48,734	415
70,270	2,723	-	-	1,058	-	54,499	469
71,591	2,734	-	-	1,079	-	60,406	544

說明：①105年度以前統計資料未含完全以電能為動力之機動車輛。

②自110年起本表稽徵部分含臨時牌照及試車牌照車輛。

③102年以前本表稽徵部分件數為本年度實徵件數，103年起件數為本年度實徵件數+以前年度實徵件數。

表 3-4 使用牌照稅稅源及稽徵 (續1完)

二、稽徵②③⑤

單位：件；新臺幣千元

會計年度(月)別 Fiscal Year (Month)		合計 Total		小客車④ Small Passenger Vehicles		大客車④ Large Passenger Vehicles	
		件數 Cases	實徵淨額 Net Actual Collection	件數 Cases	實徵淨額 Net Actual Collection	件數 Cases	實徵淨額 Net Actual Collection
民國101年度	FY 2012	818,318	6,746,234	704,076	6,380,470	8,237	48,069
民國102年度	FY 2013	841,475	6,877,053	721,750	6,498,074	8,485	49,312
民國103年度	FY 2014	891,036	7,113,879	757,724	6,699,265	9,161	52,374
民國104年度	FY 2015	929,774	7,399,701	789,392	6,967,454	9,871	55,693
民國105年度	FY 2016	943,285	7,480,160	797,441	7,035,025	9,742	55,854
民國106年度	FY 2017	955,379	7,505,772	802,690	7,051,238	9,559	53,741
民國107年度	FY 2018	967,057	7,502,433	810,058	7,040,742	9,065	51,110
民國108年度	FY 2019	982,591	7,508,282	819,377	7,037,135	9,369	52,219
民國109年度	FY 2020	1,167,431	7,433,330	990,687	6,958,456	15,987	45,822
民國110年度	FY 2021	985,884	7,389,903	810,420	6,911,142	7,461	38,911
1 月	Jan.	12,531	114,272	9,726	107,045	123	832
2 月	Feb.	23,931	91,512	21,292	86,123	346	621
3 月	Mar.	62,610	465,611	51,166	440,807	189	903
4 月	Apr.	333,575	3,117,190	276,477	2,944,702	1,954	10,809
5 月	May	331,605	2,652,084	278,633	2,495,319	1,288	7,296
6 月	June	26,460	240,129	22,382	230,035	99	622
7 月	July	12,913	63,528	10,346	59,189	72	320
8 月	Aug.	16,512	68,755	12,973	63,014	177	695
9 月	Sept.	20,770	95,914	16,867	89,396	272	1,152
10 月	Oct.	24,215	96,906	16,772	74,538	1,247	7,020
11 月	Nov.	109,857	344,352	86,190	286,655	1,378	7,199
12 月	Dec.	10,905	39,651	7,596	34,317	316	1,442

說 明：④本表稽徵部分小客車、大客車、貨車均含自用與營業用，自用全年開徵1次、營業用分兩期開徵。

⑤本表不包含免稅資料。

Table 3-4 Sources and Levy of Vehicle License Tax (Cont.1 End)

B. Levy of Vehicle License Tax

Unit : Case ; NT\$1,000

貨車④ Trucks		農村拼裝車 Flat-bodied Trucks		曳引車 Tractors		機車 Motorcycles	
件數 Cases	實徵淨額 Net Actual Collection	件數 Cases	實徵淨額 Net Actual Collection	件數 Cases	實徵淨額 Net Actual Collection	件數 Cases	實徵淨額 Net Actual Collection
90,625	264,565	-	-	2,107	21,382	13,273	31,748
91,095	269,638	-	-	2,172	21,873	17,973	38,156
98,435	291,404	-	-	2,029	22,206	23,687	48,629
99,822	296,180	-	-	2,000	21,921	28,689	58,454
100,562	295,700	-	-	2,432	26,225	33,108	67,355
100,876	298,948	-	-	2,319	25,036	39,935	76,809
100,716	299,778	-	-	2,372	25,033	44,846	85,771
101,614	303,138	-	-	2,083	21,929	50,148	93,861
102,328	305,805	-	-	2,049	22,395	56,380	100,853
103,398	309,963	-	-	2,072	22,379	62,533	107,508
1,282	3,406	-	-	64	454	1,336	2,535
1,257	2,655	-	-	10	65	1,026	2,047
4,245	12,152	-	-	34	321	6,976	11,427
29,271	111,253	-	-	402	4,720	25,471	45,706
35,432	111,198	-	-	490	5,934	15,762	32,337
1,188	3,416	-	-	119	1,271	2,672	4,786
1,111	2,370	-	-	20	163	1,364	1,486
1,672	3,025	-	-	38	254	1,652	1,767
1,599	2,734	-	-	26	191	2,006	2,441
4,558	10,242	-	-	369	3,873	1,269	1,233
20,430	45,122	-	-	445	4,595	1,414	781
1,353	2,390	-	-	55	539	1,585	963

表 3-5 契稅稅源

單位：件；新臺幣千元

會計年度別 Fiscal Year		總計 Grand Total				件數 Taxable
		件數 Cases		查定稅額 Assessment Tax		
		應稅 Taxable	免稅 Exempt	應稅 Taxable	免稅 Exempt	
民國101年度①	FY 2012	51,773	160	1,803,249		41,061
民國102年度	FY 2013	51,238	312	1,670,149	28,576	41,113
民國103年度	FY 2014	43,294	310	1,683,379	23,051	32,623
民國104年度①	FY 2015	41,883	50	2,619,758		30,501
民國105年度①	FY 2016	31,118	207	1,582,985		23,256
民國106年度	FY 2017	33,423	42	1,540,887	44,485	25,288
民國107年度	FY 2018	37,325	129	1,563,499	8,778	29,005
民國108年度	FY 2019	39,547	89	1,644,263	14,886	30,646
民國109年度	FY 2020	44,077	48	1,890,746	32,760	35,079
民國110年度	FY 2021	42,021	18	2,023,462	4,520	33,741

資料來源：依據本處財產稅科報表20903-02-11編製，103年度以前表號為2613-02-07，其中細項依報表CHT807P1編製。
說明：①101、104及105年度查定稅額無法區分應稅及免稅。

Table 3-5 Sources of Deed Tax

Unit : Case ; NT\$1,000

買賣契 Sale			典權契 Mortgage			
Cases	查定稅額 Assessment Tax		件數 Cases		查定稅額 Assessment Tax	
免稅 Exempt	應稅 Taxable	免稅 Exempt	應稅 Taxable	免稅 Exempt	應稅 Taxable	免稅 Exempt
156	1,613,589		-	-	-	-
285	1,480,674	22,291	1	-	21	-
254	1,491,415	17,776	-	-	-	-
24	2,189,322		-	-	-	-
202	1,408,471		-	-	-	-
40	1,352,359	44,465	1	-	1	-
96	1,401,153	1,486	2	-	28	-
87	1,448,051	14,281	-	-	-	-
41	1,727,206	28,431	1	-	28	-
16	1,841,443	4,459	-	-	-	-

表 3-5 契稅稅源(續1完)

單位：件；新臺幣千元

會計年度別 Fiscal Year		交換契 Exchange				贈與契 Donation	
		件數 Cases		查定稅額 Assessment Tax		件數 Cases	
		應稅 Taxable	免稅 Exempt	應稅 Taxable	免稅 Exempt	應稅 Taxable	免稅 Exempt
民國101年度①	FY 2012	1,178	-	23,655	-	9,473	1
民國102年度	FY 2013	864	-	27,200	-	9,214	1
民國103年度	FY 2014	779	-	22,763	-	9,816	2
民國104年度①	FY 2015	1,312	-	227,082	-	9,963	4
民國105年度①	FY 2016	846	-	42,435	-	6,932	5
民國106年度	FY 2017	814	-	51,062	-	7,283	2
民國107年度	FY 2018	1,025	-	47,835	-	7,244	12
民國108年度	FY 2019	1,402	-	84,509	-	7,472	2
民國109年度	FY 2020	1,302	-	49,264	-	7,653	7
民國110年度	FY 2021	1,037	-	57,078	-	7,194	1

Table 3-5 Sources of Deed Tax (Cont.1 End)

Unit : Case ; NT\$1,000

查定稅額 Assessment Tax		分割契 Division				占有契 Staking			
		件數 Cases		查定稅額 Assessment Tax		件數 Cases		查定稅額 Assessment Tax	
應稅 Taxable	免稅 Exempt	應稅 Taxable	免稅 Exempt	應稅 Taxable	免稅 Exempt	應稅 Taxable	免稅 Exempt	應稅 Taxable	免稅 Exempt
165,657		61	3	348		-	-	-	
162,003	4,874	46	26	251	1,411	-	-	-	-
168,326	248	76	54	874	5,027	-	-	-	-
202,324		57	22	1,030		-	-	-	
131,397		84	-	683		-	-	-	
137,278	20	36	-	186	-	1	-	1	-
114,410	1,860	49	21	74	5,432	-	-	-	-
111,439	605	27	-	264	-	-	-	-	-
114,135	4,329	42	-	113	-	-	-	-	-
124,530	20	48	1	402	40	1	-	9	-

表 3-6 印花稅稅源

單位：新臺幣千元

會計年度別 Fiscal Year	合計① Total	出售印花稅票 Taxes Stamps	彙總自繳稅額		
			金融業 Finance	保險業 Insurance	教育業 Education
民國104年度 FY 2015	4,529,341	462,108	1,337,492	784,326	33,725
民國105年度 FY 2016	4,494,029	457,681	1,350,707	811,200	33,033
民國106年度 FY 2017	4,458,982	391,169	1,388,677	848,806	32,971
民國107年度 FY 2018	4,964,329	429,306	1,530,400	991,558	34,254
民國108年度 FY 2019	5,077,541	358,850	1,633,444	913,147	35,499
民國109年度 FY 2020	5,289,562	395,632	1,557,165	913,385	35,055
民國110年度 FY 2021	5,497,663	428,457	1,524,267	995,824	31,483

資料來源：依據本處機會稅科報表20903-02-12編製，103年度以前表號為2613-02-15。

說明：①104年至105年為本年度實徵淨額，其餘年度為本年度實徵數。

Table 3-6 Sources of Stamp Tax

Unit : NT\$1,000

Paid by Filing a Collective Tax Return					
醫療業 Medical Industry	傳播業 Broadcasting	營建業 Construction	公用事業 Utilities	服務業 Service Industry	其他 Others
143,350	1,781	20,314	19,936	31,553	828,661
165,500	1,714	33,683	28,150	35,328	779,799
172,347	1,604	33,412	34,452	37,724	655,487
185,549	1,625	44,549	31,234	48,416	775,369
203,972	1,600	60,953	38,827	63,693	742,609
204,705	1,403	64,118	35,275	69,402	769,017
206,993	1,301	54,728	53,048	71,571	711,984

表 3-6 印花稅稅源(續1完)

單位：新臺幣千元

會計年度別 Fiscal Year	大額繳納				
	遺產分割 協議書 Partition of Estate Agreements	不動產買賣 Real Estate Transactions	不動產交換 Real Estate Exchanges	不動產贈與 Real Estate Gifts	不動產 分割合併 Partition/Merger of Real Estate
民國104年度 FY 2015	42,440	301,075	10,922	55,770	12,703
民國105年度 FY 2016	43,983	199,862	1,010	41,008	36,686
民國106年度 FY 2017	41,333	221,384	1,999	42,784	4,895
民國107年度 FY 2018	44,168	242,230	2,697	36,034	2,468
民國108年度 FY 2019	50,435	284,773	5,313	37,660	2,556
民國109年度 FY 2020	49,262	307,832	3,325	39,517	1,901
民國110年度 FY 2021	48,594	308,108	5,510	38,452	911

Table 3-6 Sources of Stamp Tax(Cont.1 End)

Unit : NT\$1,000

Large Sum by Filling a Collective Tax Return					
承攬契據 Contracting Agreements	銀錢收據 Receipts for Monetary Payments	押標金收據 Tender Bond for Monetary Payments	不動產信託 Real Estate Trust	買賣動產 Sale and Purchase of Movable Property	其他 Others
427,499	11,030	-	245	61	4,350
457,769	11,914	2	154	61	4,786
488,171	58,450	243	103	25	2,946
538,484	21,749	0	929	49	3,261
628,318	12,507	32	104	26	3,224
822,604	15,762	8	141	77	3,975
918,505	89,510	52	257	214	7,892

表 3-7 娛樂稅稅源

單位：家(件)；新臺幣千元

年底 End of Year	總計		電影		歌廳		撞球場		保齡球館	
	Grand Total		The Cinemas		Music Halls		Billards Halls		Bowling Alleys	
	家數 No. of Amuseme nt Place	實徵稅額 Actual Collection	家數 No. of Amusem ent Place	實徵稅額 Actual Collection	家數 No. of Amusem ent Place	實徵稅額 Actual Collection	家數 No. of Amusem ent Place	實徵稅額 Actual Collection	家數 No. of Amusem ent Place	實徵稅 Actual Collection
民國101年底 End of 2012	1,624	224,138	37	57,769	1	72	-	-	-	-
民國102年底 End of 2013	1,615	228,927	37	61,062	1	72	-	-	-	-
民國103年底 End of 2014	1,549	234,875	37	61,738	2	128	-	-	-	-
民國104年底 End of 2015	1,490	278,078	36	66,715	2	101	-	-	-	-
民國105年底 End of 2016	1,545	237,943	37	60,904	2	129	-	-	-	-
民國106年底 End of 2017	1,883	255,693	38	61,765	2	114	-	-	-	-
民國107年底 End of 2018	2,264	272,037	36	59,648	2	127	-	-	-	-
民國108年底 End of 2019	2,284	267,798	34	53,861	3	236	-	-	-	-
民國109年底 End of 2020	2,141	149,068	32	26,132	3	188	-	-	-	-
民國110年底 End of 2021	1,484	61,044	29	10,472	2	28	-	-	-	-

資料來源：依據本處機會稅科報表20903-02-13編製，103年度以前表號為2613-02-13。

Table 3-7 Sources of Amusement Tax

Unit : Unit(Case) ; NT\$1,000

高爾夫球場		舞廳舞場		電子遊戲機		有節目餐飲業		視聽視唱業	
Golf Course		Dance Halls		Arcade		Entertainment Restaurants		KTV、MTV	
家數	實徵稅額	家數	實徵稅額	家數	實徵稅額	家數	實徵稅額	家數	實徵稅額
No. of Amusement Place	Actual Collection	No. of Amusement Place	Actual Collection	No. of Amusement Place	Actual Collection	No. of Amusement Place	Actual Collection	No. of Amusement Place	Actual Collection
16	3,425	21	9,149	65	5,721	37	4,329	1,102	73,187
19	3,251	22	10,244	53	5,102	41	3,880	1,065	71,752
17	3,230	22	9,391	54	4,535	42	4,831	1,009	71,490
14	3,101	22	10,820	54	4,638	45	4,925	951	70,882
12	2,796	21	11,712	56	4,762	48	4,466	916	68,694
12	2,674	21	9,949	62	4,822	46	4,406	885	68,345
9	2,603	22	9,775	52	4,806	45	4,308	898	69,512
9	2,449	21	9,675	57	4,439	45	4,512	882	69,936
8	2,948	17	6,552	53	3,174	50	2,626	769	49,865
9	1,444	17	1,687	26	1,056	38	508	366	17,841

表 3-7 娛樂稅稅源 (續1完)

單位：家(件)；新臺幣千元

年底 End of Year	合計 Total		資訊休閒業(網咖) Internet Cafe		電動搖搖馬 Kiddie Ride		其他 具娛樂性之運物販賣機 Claw Machines	
			家數 No. of Amusement Place	實徵稅額 Actual Collection	家數 No. of Amusement Place	實徵稅額 Actual Collection	家數 No. of Amusement Place	實徵稅額 Actual Collection
	家數	實徵稅額						
民國101年底 End of 2012	256	11,356	127	4,677	21	52	63	1,498
民國102年底 End of 2013	250	9,412	115	4,419	19	50	70	1,556
民國103年底 End of 2014	246	9,849	99	3,769	23	51	78	1,615
民國104年底 End of 2015	244	12,577	75	3,149	23	55	91	1,778
民國105年底 End of 2016	281	12,215	74	2,896	19	57	107	1,945
民國106年底 End of 2017	528	16,158	74	3,032	18	69	210	2,799
民國107年底 End of 2018	923	29,225	66	3,151	21	81	629	16,597
民國108年底 End of 2019	974	37,909	62	2,929	24	101	673	24,560
民國109年底 End of 2020	923	27,917	58	2,508	25	88	642	18,100
民國110年底 End of 2021	798	12,533	44	796	8	26	542	8,800

Table 3-7 Sources of Amusement Tax (Cont.1 End)

Unit : Unit(Case) ; NT\$1,000

Others								臨時公演		違章補徵	
機動遊藝樂園		機動遊艇、動力飛行器		實境體感娛樂設施		其他		Temp. Public Shows		Fines of Tax Misconduct and Violation	
Amusement Park		Mobile Yacht, Powered Aircraft		Virtual Reality Facility		Others					
家數	實徵稅	家數	實徵稅額	家數	實徵稅	家數	實徵稅	件數	實徵稅	件數	實徵稅
No. of Amusement Place	Actual Collection	No. of Amusement Place	Actual Collection	No. of Amusement Place	Actual Collection	No. of Amusement Place	Actual Collection	No. of Cases	Actual Collection	No. of Cases	Actual Collection
9	1,839	1	41	-	-	35	3,249	89	59,130	-	-
9	1,695	1	74	-	-	36	1,619	127	64,153	-	-
9	1,611	1	60	-	-	36	2,744	120	69,682	-	-
10	5,958	-	4	-	-	45	1,634	122	104,319	-	-
12	5,005	-	7	-	-	69	2,306	172	72,265	-	-
20	6,909	-	-	-	-	206	3,348	289	87,460	-	-
14	5,009	-	-	-	-	193	4,387	277	92,033	-	-
10	4,593	-	-	10	1,410	195	4,316	255	84,371	4	410
11	3,073	-	-	9	948	178	3,199	284	29,542	2	125
8	1,124	-	-	6	283	190	1,506	199	15,456	-	19

表 3-8 各項稅捐劃解百分率一覽表

Table 3-8 The Distribution Rate of Current Taxes

單位：%		Unit：%						
稅目 Item of Tax	國庫 National Treasury	中央統籌 分配專戶 Distribution Tax of Central Gov't	直轄市庫 Municipality Treasury	市庫 City Treasury	縣庫 County Treasury	縣統籌分 配專戶 Account Distributed by County	鄉鎮庫 Township Treasuries	
地價稅 Land Value Tax	-	-	100	-	-	-	-	
田賦 Farming Land Tax	-	-	100	-	-	-	-	
土地增值稅 Land Value Increment Tax	-	-	100	-	-	-	-	
房屋稅 House Tax	-	-	100	-	-	-	-	
使用牌照稅 Vehicle License Tax	-	-	100	-	-	-	-	
契稅 Deed Tax	-	-	100	-	-	-	-	
印花稅 Stamp Tax	-	-	100	-	-	-	-	
娛樂稅 Amusement Tax	-	-	100	-	-	-	-	
特別稅 Special Tax Levies	-	-	100	-	-	-	-	
臨時稅 Provisional Tax Levies	-	-	100	-	-	-	-	
工程受益費 Construction Benefit Fee	-	-	100	-	-	-	-	
罰鍰收入 Punitive Fine Revenue	-	-	100	-	-	-	-	

資料來源：根據財政收支劃分法資料編製。

說明：田賦自76年第2期起停徵。

本 頁 空 白

表 3-9 各項稅捐現行稅率表
Table 3-9 Current Tax Rates for Taxation

一、地價稅 Land Value Tax

課 稅 類 別 及 計 算 公 式

(一)一般用地累進稅率

第 1 級：應徵稅額＝課稅地價(未超過累進起點地價者)×稅率(10‰)

第 2 級：應徵稅額＝課稅地價(超過累進起點地價未達5倍者)×稅率(15‰)－累進差額(累進起點地價×0.005)

第 3 級：應徵稅額＝課稅地價(超過累進起點地價5倍至10倍者)×稅率(25‰)－累進差額(累進起點地價×0.065)

第 4 級：應徵稅額＝課稅地價(超過累進起點地價10倍至15倍者)×稅率(35‰)－累進差額(累進起點地價×0.175)

第 5 級：應徵稅額＝課稅地價(超過累進起點地價15倍至20倍者)×稅率(45‰)－累進差額(累進起點地價×0.335)

第 6 級：應徵稅額＝課稅地價(超過累進起點地價20倍以上者)×稅率(55‰)－累進差額(累進起點地價×0.545)

(二)特別稅率

1.自用住宅用地：2‰

2.勞工宿舍用地：2‰

3.國民住宅用地：2‰

4.公共設施保留地：6‰

5.公有土地：10‰

6.事業直接使用之土地，按10‰計徵地價稅，包含：

(1)工業用地、礦業用地

(2)私立公園、動物園、體育場所用地

(3)寺廟、教堂用地、政府指定之名勝古蹟用地

(4)經主管機關核准設置之加油站及依都市計畫法規定設置之供公眾使用之停車場用地

(5)其他經行政院核定之土地

資料來源：根據本處財產稅科提供資料編製。

說明：地價稅累進起點地價，以本市土地7公畝之平均地價為準。但不包括工業用地、礦業用地、農業用地及免稅土地在內。

表 3-9 各項稅捐現行稅率表 (續1)
Table 3-9 Current Tax Rates for Taxation (Cont.1)

二、土地增值稅 Land Value Increment Tax

課 稅 類 別 及 計 算 公 式

(一)一般用地累進稅率

第 1 級：應徵稅額=土地漲價總數額【超過原規定地價或前次移轉時申報現值(按臺灣地區消費者物價總指數調整後)未達百分之一百者】×稅率(20%)

第 2 級：應徵稅額=土地漲價總數額【超過原規定地價或前次移轉時申報現值(按臺灣地區消費者物價總指數調整後)在百分之一百以上未達百分之二百者】×【稅率(30%)－[(30%－20%)×減徵率]】

－累進差額(按臺灣地區消費者物價總指數調整後之原規定地價或前次移轉現值×A)

註：持有土地年限未超過20年者，無減徵，A為0.10

持有土地年限超過20年以上者，減徵率為20%，A為0.08

持有土地年限超過30年以上者，減徵率為30%，A為0.07

持有土地年限超過40年以上者，減徵率為40%，A為0.06

第 3 級：應徵稅額=土地漲價總數額【超過原規定地價或前次移轉時申報現值(按臺灣地區消費者物價總指數調整後)在百分之二百以上者】×【稅率(40%)－[(40%－20%)×減徵率]】－累進差額(按臺灣地區消費者物價總指數調整後之原規定地價或前次移轉現值×B)

註：持有土地年限未超過20年者，無減徵，B為0.30

持有土地年限超過20年以上者，減徵率為20%，B為0.24

持有土地年限超過30年以上者，減徵率為30%，B為0.21

持有土地年限超過40年以上者，減徵率為40%，B為0.18

(二)自用住宅用地單一稅率10%

表 3-9 各項稅捐現行稅率表 (續2)

三、房屋稅		
房屋使用情形	持有戶數	稅 率 %
住家用	單一自住	全國1戶 相當稅率0.6% ^(註1)
	自家用	全國3戶內 1.2%
	公益出租人出租使用	不限 1.2% (109年7月1日起相當稅率0.6%) ^(註2)
	社會住宅包租代管	不限 相當稅率0.6%
其他住家用	公有房屋供住家使用	
	出租供符合本市社會住宅承租資格者使用，且持有主管機關核發之出租人核定函	
	經勞工主管機關核發證明文件之勞工宿舍	
	公立學校之學生宿舍，由民間機構與主辦機關簽訂投資契約，投資興建並租與該校學生作宿舍使用，且約定於營運期間屆滿後，轉移該宿舍之所有權予政府	
	公司共有，除共有人符合自住外	
	其他非自住	本市2戶以內
本市3戶以內		每戶3.6%

資料來源：根據本處財產稅科提供資料編製。

註：

- 1、家戶持有全國單一自住並設立戶籍，且符合本市都市計畫規定可作住宅使用的房屋，自109年7月1日起課稅現值折減比率由16%提高為50%(相當稅率由1%降為0.6%)，其現值最高折減額度為750萬元(即稅額折減上限為9萬元)。另使用權房屋之使用權人本人、配偶及未成年子女，全國僅有該使用權房屋，且於該屋辦竣戶籍登記，並符合本市都市計畫規定可作住宅使用的房屋，亦得適用上開規定。

Table 3-9 Current Tax Rates for Taxation (Cont.2)

三、House Tax			稅 率 %	
房屋使用情形	持有戶數			
非住家用	營業用		3%	
	私人醫院、診所或自由職業事務所使用		3%	
	人民團體等非營業用		2%	
停車場或防空避難室違規使用	住家用		3.6%	
	營業用		5%	
	私人醫院、診所或自由職業事務所使用		5%	
	非住家非營業用		2.5%	
空置房屋(依使用執照所載用途別或都市計畫分區使用範圍認定)	住家用途	非自住-起造人待銷售	於起課房屋稅1年6個月內未出售者 2%	
		其他非自住	本市2戶以內	每戶2.4%
			本市3戶以上	每戶3.6%
	非住家用途	營業用途		不限 2%
		醫院、診所用途		
		其他用途		

註：

- 2、符合月租金收取不超過中央主管機關公告當年度社會住宅包租代管計畫簽約租金上限者，比照單一自住房屋，自109年7月1日起課稅現值折減50%(相當稅率0.6%)，其現值最高折減額度為750萬元(即稅額折減上限為9萬元)。

表 3-9 各項稅捐現行稅率表 (續3)

單位：新臺幣元		四、使用牌照稅		
汽缸總排氣量 (立方公分) Exhust (CC)	小客車(每車乘人座位9人以下者) Small Passenger Vehicles (Seating 9 or Fewer)			大客車(每車乘人 Large Passenger Vehicles
	自用 Private	營業用 Commercial		全年 Year
	全年 Year	全年 Year	每期 Period	
500以下 Under 500	1,620	900	450	-
501-600	2,160	1,260	630	1,080
601-1,200	4,320	2,160	1,080	1,800
1,201-1,800	7,120	3,060	1,530	2,700
1,801-2,400	11,230	6,480	3,240	3,600
2,401-3,000	15,210	9,900	4,950	4,500
3,001-3,600	28,220	16,380	8,190	5,400
3,601-4,200	28,220	16,380	8,190	6,300
4,201-4,800	46,170	24,300	12,150	7,200
4,801-5,400	46,170	24,300	12,150	8,100
5,401-6,000	69,690	33,660	16,830	9,000
6,001-6,600	69,690	33,660	16,830	9,900
6,601-7,200	117,000	44,460	22,230	10,800
7,201-7,800	117,000	44,460	22,230	11,700
7,801-8,400	151,200	56,700	28,350	12,600
8,401-9,000	151,200	56,700	28,350	13,500
9,001-9,600	151,200	56,700	28,350	14,400
9,601-10,200	151,200	56,700	28,350	15,300
10,201以上 Above 10,201	151,200	56,700	28,350	16,200

資料來源：根據本處機會稅科提供資料編製。

說明：1、小客貨兩用車之稅額按自用小客車之稅額課徵；曳引車之稅額按貨車稅額加徵 30%。

2、自用車、機車(151立方公分以上)全年1期，營業車全年分2期課徵

Table 3-9 Current Tax Rates for Taxation (Cont.3)

Vehicle License Tax				Unit : N.T.\$	
座位10人以上者) (Seating 10 or more)	貨車 Trucks		汽缸總排氣量 (立方公分) Exhust (CC)	機車 Motorcycles	
	每期 Period	全年 Year		每期 Period	全年 Year
-	900	450	150以下 Under 150	-	-
540	1,080	540	151-250	800	
900	1,800	900	251-500	1,620	
1,350	2,700	1,350	501-600	2,160	
1,800	3,600	1,800	601-1,200	4,320	
2,250	4,500	2,250	1,201-1,800	7,120	
2,700	5,400	2,700	1,801以上 Above 1,801	11,230	
3,150	6,300	3,150			
3,600	7,200	3,600	臨時牌照 Vehicles with Temporary Licence Plate		
4,050	8,100	4,050	車別 Vehicle Type	每日稅額 Day	
4,500	9,000	4,500	小客車 Small Passenger Vehicles	41	
4,950	9,900	4,950	大客車 Large Passenger Vehicles	23	
5,400	10,800	5,400	貨車 Trucks	22	
5,850	11,700	5,850	曳引車 Tractors	28	
6,300	12,600	6,300	機車 Motorcycles	5	
6,750	13,500	6,750	試車牌照 Vehicles with Trial Run Licence Plate		
7,200	14,400	7,200	車別 Vehicle Type	每日稅額 Day	
7,650	15,300	7,650	小客車 Small Passenger Vehicles	414	
8,100	16,200	8,100	機車 Motorcycles	30	

表 3-9 各項稅捐現行稅率表 (續4)

Table 3-9 Current Tax Rates for Taxation (Cont.4)

單位：新臺幣元		四、使用牌照稅 (續1完) Vehicle License Tax (Cont.1 End)		Unit : N.T.\$	
馬達最大馬力 Maximum Horsepower		完全以電能為動力之電動小客車 (每車乘人座位9人以下者) Small Passenger Vehicles Fully Powered by Electricity (Seating 9 or Fewer)			
		自用 Private	營業用 Commercial		
英制馬力(HP)	公制馬力(PS)	全年 Year	全年 Year	每期 Period	
38以下 Under 38	38.6以下 Under 38.6	1,620	900	450	
38.1-56	38.7-56.8	2,160	1,260	630	
56.1-83	56.9-84.2	4,320	2,160	1,080	
83.1-182	84.3-184.7	7,120	3,060	1,530	
182.1-262	184.8-265.9	11,230	6,480	3,240	
262.1-322	266.0-326.8	15,210	9,900	4,950	
322.1-414	326.9-420.2	28,220	16,380	8,190	
414.1-469	420.3-476.0	46,170	24,300	12,150	
469.1-509	476.1-516.6	69,690	33,660	16,830	
509.1以上 Above 509.1	516.7以上 Above 516.7	117,000	44,460	22,230	
英制馬力(HP)	公制馬力(PS)	完全以電能為動力之電動大客車 (每車乘人座位10人以上者) Large Passenger Vehicles Fully Powered by Electricity (Seating 10 or more)		完全以電能為動力 之電動貨車 Trucks Fully Powered by Electricity	
		全年 Year			
138以下 Under 138	140.1以下 Under 140.1	4,500		4,500	
138.1-200	140.2-203	6,300		6,300	
200.1-247	203.1-250.7	8,100		8,100	
247.1-286	250.8-290.3	9,900		9,900	
286.1-336	290.4-341	11,700		11,700	
336.1-361	341.1-366.4	13,500		13,500	
361.1以上 Above 361.1	366.5以上 Above 366.5	15,300		15,300	
英制馬力(HP)	公制馬力(PS)	完全以電能為動力之電動機車 Motorcycles Fully Powered by Electricity			
		全年 Year			
20.19以下 Under 20.19	21.54以下 Under 21.54	-			
20.20-40.03	21.55-42.71	800			
40.04-50.07	42.72-53.43	1,620			
50.08-58.79	53.44-62.73	2,160			
58.80-114.11	62.74-121.76	4,320			
114.12以上 Above 114.12	121.77以上 Above 121.77	7,120			

資料來源：根據本處機稅科提供資料編製。

說明：依據使用牌照稅法第5條第2項，本市完全以電能為動力之電動汽車，自101年1月6日起至114年12月31日止免徵使用牌照稅；完全以電能為動力之電動機車，自107年1月1日起至114年12月31日止免徵使用牌照稅。

表 3-9 各項稅捐現行稅率表 (續5)

Table 3-9 Current Tax Rates for Taxation (Cont.5)

五、契稅 Deed Tax	
課 徵 標 的	稅 率 %
1、買賣契按契價	6
2、典權契按契價	4
3、交換契按契價	2
4、贈與契按契價	6
5、分割契按契價	2
6、占有契按契價	6

資料來源：根據本處財產稅科提供資料編製。

表 3-9 各項稅捐現行稅率表 (續6)

Table 3-9 Current Tax Rates for Taxation (Cont.6)

六、印花稅 Stamp Tax	
課 徵 標 的	稅 率 %
1、銀錢收據 (但兼具營業發票性質之銀錢收據及兼具銀錢收據性質之營業發票不包括在內)	4
收受押標金收據 (營業人、機關、團體或個人書立收到票據所出具載有票據名稱、號碼及金額之收據，免貼用印花稅票)	1
2、買賣動產契據	每件新臺幣12元
3、承攬契據	1
4、典賣、讓售及分割不動產契據	1

資料來源：根據本處機會稅科提供資料編製。

表 3-9 各項稅捐現行稅率表 (續7完)

Table 3-9 Current Tax Rates for Taxation (Cont.7 End)

七、娛樂稅 Amusement Tax	
課 徵 標 的	稅 率 %
1、電影，外國語言片	2.5
電影，本國語言片	1
2、職業性歌唱、舞蹈、馬戲、魔術、技藝表演及夜總會之各種表演	5
(1)票價或收費額在新臺幣1,500元以下者	1
(2)票價或收費額超過新臺幣1,500元，未逾3,000元者	2.5
(3)票價或收費額超過新臺幣3,000元者	5
3、戲劇、音樂演奏、說書及非職業性歌唱、舞蹈等表演	1
4、各種競技比賽及其他提供娛樂設施供人娛樂	2.5
5、舞廳或舞場	25
6、高爾夫球場及其他提供娛樂設施供人娛樂	2.5

資料來源：根據本處機會稅科提供資料編製。

說明：因應嚴重特殊傳染性肺炎疫情影響，自109年12月1日起至111年6月30日止，娛樂稅徵收率全面減半課徵。

表 3-10 查(核)定開徵數、未徵數情形

總計

單位：件；新臺幣千元

會計年度及稅目別 Fiscal Year & Item of Tax		查(核)定開徵數		實徵數		減免註銷數	
		Opening Collection for Assessed (Verified) (1)=(2)+(3)+(4)+(5)+(6)+(7)		Tax Collected (2)		Cancelled (3)	
		件數 Cases	金額 Amount	件數 Cases	金額 Amount	件數 Cases	金額 Amount
民國102年度	FY 2013	3,230,735	71,479,763	3,051,611	66,128,063	25,500	2,144,803
民國103年度	FY 2014	3,248,053	73,613,861	3,075,087	67,177,463	31,784	3,405,738
民國104年度	FY 2015	3,315,255	84,295,269	3,154,605	76,717,105	26,101	4,677,149
民國105年度	FY 2016	3,304,275	82,087,609	3,145,833	75,254,209	26,010	3,599,140
民國106年度	FY 2017	3,345,892	81,475,626	3,174,384	74,906,073	24,980	3,384,879
民國107年度	FY 2018	3,411,614	77,626,702	3,220,806	71,808,283	25,951	2,912,069
民國108年度	FY 2019	3,467,418	80,545,676	3,269,287	74,743,065	26,274	3,210,397
民國109年度	FY 2020	3,743,019	83,088,405	3,535,855	75,912,738	26,165	3,506,359
民國110年度	FY 2021	3,547,937	83,475,672	3,340,357	76,769,699	24,225	2,795,245
民國111年度	FY 2022	3,566,644	83,330,268	3,357,740	76,723,680	24,590	2,863,999
地價稅 Land Value Tax		996,512	30,413,012	936,253	28,499,609	5,082	487,415
土地增值稅 Land Value Increment Tax		62,679	19,883,107	57,537	17,028,958	3,642	1,997,498
房屋稅 House Tax		1,127,951	17,017,387	1,106,989	16,448,000	5,376	39,270
使用牌照稅 Vehicle License Tax		1,129,483	8,100,318	1,047,325	7,382,989	10,122	252,699
契稅 Deed Tax		42,306	1,855,556	39,746	1,758,028	2,027	80,946
印花稅 Stamp Tax		141,316	5,526,733	140,211	5,488,138	-2,413	-2,621
娛樂稅 Amusement Tax		28,256	111,175	22,557	89,550	147	3,419
特別稅 Special Tax Levies		-	-	-	-	-	-
臨時稅 Provisional Tax Levies		-	-	-	-	-	-
罰鍰 Fines		38,141	422,980	7,122	28,408	607	5,372

資料來源：依據本處稅務管理科報表20903-90-01及20903-90-02編製，103年度以前表號為2613-90-11及2613-90-12。

說明：1.本表以開徵始日為統計基礎。

2.總計=本年度+以前年度。

3.查(核)定開徵數係原開徵始日在上年度12月31日以前之查(核)定開徵稅款，未逾徵收期間而仍未徵起者。

Table 3-10 The Management of Opening Collection for Assessed (Verified)
and of Tax Not Collected

Grand Total

Unit : Case : NT\$1,000

逾徵收期間數 Overdue (4)		逾執行期間數 Exceeded Compulsory Execution Period (5)		逾核課期間數 Excess Assessment (6)		未徵數餘額 Balance of Tax Not Collected (7)=(8)+(9)+(10)+(11)+(12)+(13)	
件數 Cases	金額 Amount	件數 Cases	金額 Amount	件數 Cases	金額 Amount	件數 Cases	金額 Amount
13,596	117,944	-	-	308	4,182	139,720	3,084,771
14,123	120,263	-	-	291	10,483	126,768	2,899,915
9,820	101,197	-	-	320	7,997	124,409	2,791,821
795	1,480	-	-	271	3,733	131,366	3,229,048
340	841	214	30,743	246	3,245	145,728	3,149,845
206	205	28	669	249	11,456	164,374	2,894,019
163	113	3	49	238	3,141	171,453	2,588,910
153	275	-	-	249	2,954	180,597	3,666,079
156	333	28	11,371	272	3,715	182,899	3,895,309
134	241	145	33,020	235	3,216	183,800	3,706,112
85	15	34	13,259	190	3,006	54,868	1,409,709
-	-	-	-	-	-	1,500	856,652
15	3	29	18,864	4	14	15,538	511,237
27	56	74	582	40	186	71,895	463,806
-	-	-	-	-	-	533	16,581
-	-	-	-	-	-	3,518	41,215
1	1	-	-	-	-	5,551	18,205
-	-	-	-	-	-	-	-
-	-	-	-	-	-	-	-
6	166	8	317	1	10	30,397	388,706

說明：4.本年度「取得執行憑證數」105年以前件數及金額無法區分為未逾徵收期間或已逾徵收期間惟未逾執行期間。

5.印花稅實徵數未含代售印花稅票稅款。

6.罰鍰實徵數僅財務罰鍰，未含罰金罰鍰。

表 3-10 查(核)定開徵數、未徵數情形 (續1)

總計 (續1)

單位：件；新臺幣千元

會計年度及稅目別 Fiscal Year & Item of Tax		未 徵 數 餘 額					
		繳款書未送達未徵數 Have not Been Served the Payment Notice (8)		未逾限繳日未徵數 Have Not Exceeded the Deadline of Payment (9)		行政救濟未徵數 Aministrative Remedies (10)	
		件數 Cases	金額 Amount	件數 Cases	金額 Amount	件數 Cases	金額 Amount
民國102年度	FY 2013	29,042	731,268	15,172	433,194	302	135,338
民國103年度	FY 2014	28,055	347,556	14,805	734,342	286	153,360
民國104年度	FY 2015	28,947	241,824	16,442	893,265	192	184,848
民國105年度	FY 2016	26,840	382,003	17,109	845,212	301	275,406
民國106年度	FY 2017	29,651	410,760	19,859	678,336	215	397,693
民國107年度	FY 2018	28,215	349,507	18,991	555,752	167	194,539
民國108年度	FY 2019	27,632	291,675	20,470	490,536	68	76,514
民國109年度	FY 2020	31,936	271,963	24,176	1,322,911	65	81,160
民國110年度	FY 2021	29,908	311,927	23,714	1,354,479	47	56,312
民國111年度	FY 2022	32,069	374,750	19,613	1,002,887	110	67,433
地價稅 Land Value Tax		28,119	187,017	7,527	379,586	33	16,018
土地增值稅 Land Value Increment Tax		912	166,918	544	359,091	2	410
房屋稅 House Tax		1,415	8,248	4,124	193,768	71	4,336
使用牌照稅 Vehicle License Tax		1,007	6,823	3,010	13,940	-	-
契稅 Deed Tax		45	1,343	475	14,994	-	-
印花稅 Stamp Tax		234	3,565	3,264	37,487	-	-
娛樂稅 Amusement Tax		240	311	161	288	1	178
特別稅 Special Tax Levies		-	-	-	-	-	-
臨時稅 Provisional Tax Levies		-	-	-	-	-	-
罰鍰 Fines		97	525	508	3,734	3	46,491

Table 3-10 The Management of Opening Collection for Assessed (Verified) and of Tax Not Collected (Cont.1)

Grand Total (Cont.1)

Unit : Case : NT\$1,000

Balance of Tax Not Collected							
分期繳納 未徵數 Pay by Stages (11)		特殊原因未徵數 Special Reason (12)		欠稅數 Tax in Arrears (13)=(14)+...+(20)		送達未逾滯納期欠稅數 Delivery of Notice not yet Exceeded Delinquency Period (14)	
件數 Cases	金額 Amount	件數 Cases	金額 Amount	件數 Cases	金額 Amount	件數 Cases	金額 Amount
-	-	4,744	24,238	90,369	1,760,080	2,051	16,887
-	-	3,944	21,186	79,678	1,643,471	1,975	72,277
-	-	3,306	20,704	75,522	1,451,180	4,574	40,031
46	28,311	2,232	4,211	84,838	1,693,905	4,027	37,125
4	648	1,918	4,182	94,081	1,658,227	5,089	43,663
-	-	2,028	4,582	114,973	1,789,640	3,990	32,124
2	24	2,137	4,938	121,144	1,725,223	2,712	21,677
140	258,356	1,918	4,386	122,362	1,727,303	2,402	23,125
232	407,572	1,859	3,956	127,139	1,761,062	3,430	28,625
348	494,873	1,883	3,756	129,777	1,762,413	2,452	19,968
60	267,747	1,165	2,400	17,964	556,943	337	7,727
1	70	-	-	41	330,162	3	578
216	224,018	331	77	9,381	80,791	840	2,943
17	126	321	924	67,540	441,994	868	6,696
-	-	-	-	13	245	-	-
-	-	-	-	20	164	-	-
54	2,913	32	5	5,063	14,510	78	118
-	-	-	-	-	-	-	-
-	-	-	-	-	-	-	-
-	-	34	351	29,755	337,605	326	1,906

表 3-10 查(核)定開徵數、未徵數情形 (續2)
總計 (續2完)

單位：件；新臺幣千元

會計年度及稅目別 Fiscal Year & Item of Tax		未徵數餘額					
		欠稅數					
		待移送執行		移送執行未結		取得執行憑證數	
		Pending for Compulsory Execution (15)		Pending Case Under Compulsory Execution (16)		Not Yet Exceeded Collection Period (17)	
		件數 Cases	金額 Amount	件數 Cases	金額 Amount	件數 Cases	金額 Amount
民國102年度	FY 2013	3,656	117,762	25,936	1,056,698	58,722	563,693
民國103年度	FY 2014	2,008	40,633	25,516	1,024,274	50,100	496,408
民國104年度	FY 2015	3,028	49,383	23,653	940,953	44,195	416,342
民國105年度	FY 2016	3,181	132,756	28,849	960,623	48,717	555,974
民國106年度	FY 2017	3,367	76,416	33,974	980,924	30,750	276,594
民國107年度	FY 2018	5,185	117,598	45,520	1,037,088	35,079	289,407
民國108年度	FY 2019	4,050	68,489	42,019	955,483	43,967	336,655
民國109年度	FY 2020	2,832	54,968	35,179	885,958	50,973	399,127
民國110年度	FY 2021	3,947	81,537	29,355	792,672	44,277	290,106
民國111年度	FY 2022	2,178	78,923	27,005	610,519	44,710	302,380
地價稅 Land Value Tax		763	71,763	5,306	122,005	5,204	58,109
土地增值稅 Land Value Increment Tax		2	52	16	322,209	7	1,248
房屋稅 House Tax		520	1,520	4,557	35,566	1,497	6,504
使用牌照稅 Vehicle License Tax		740	4,766	12,910	97,399	23,122	139,568
契稅 Deed Tax		4	21	-	-	-	-
印花稅 Stamp Tax		-	-	13	39	-	-
娛樂稅 Amusement Tax		27	26	445	1,372	1,300	2,046
特別稅 Special Tax Levies		-	-	-	-	-	-
臨時稅 Provisional Tax Levies		-	-	-	-	-	-
罰鍰 Fines		122	776	3,758	31,929	13,580	94,905

Table 3-10 The Management of Opening Collection for Assessed (Verified)
and of Tax Not Collected (Cont.2 End)

Grand Total (Cont.2 End)

Unit : Case ; NT\$1,000

Balance of Tax Not Collected					
Tax in Arrears					
Execution Certificate		移送執行結(銷)案		無法執行欠稅數	
已逾徵收期間惟未逾執行期間 Exceeded Collection Period Not Yet Exceeded Compulsory Execution Period (18)		Cases Closed Under Compulsory Execution (19)		Unable to Carry out Compulsory Execution (20)	
件數 Cases	金額 Amount	件數 Cases	金額 Amount	件數 Cases	金額 Amount
5,041	-	4	-	91	653
9,670	-	6	0	73	209
4,158	-	8	105	64	208
7,207	-	10	13	54	207
20,851	280,618	5	5	45	5
25,150	313,392	15	26	34	4
28,350	342,913	3	1	43	6
30,922	364,118	7	2	47	5
46,075	568,116	3	0	52	6
53,351	750,614	22	0	59	8
6,322	297,334	-	-	32	4
13	6,074	-	-	-	-
1,957	34,257	1	0	9	1
29,871	193,563	20	0	9	1
9	224	-	-	-	-
7	124	-	-	-	-
3,213	10,948	-	-	-	-
-	-	-	-	-	-
-	-	-	-	-	-
11,959	208,088	1	0	9	2

表 3-10 查(核)定開徵數、未徵數情形(續3)

一、本年度

單位：件；新臺幣千元

會計年度及稅目別 Fiscal Year & Item of Tax		查(核)定開徵數		實徵數		減免註銷數	
		Opening Collection for Assessed (Verified) (1)=(2)+(3)+(4)+(5)+(6)+(7)		Tax Collected (2)		Cancelled (3)	
		件數 Cases	金額 Amount	件數 Cases	金額 Amount	件數 Cases	金額 Amount
民國102年度	FY 2013	3,061,761	68,463,016	2,974,908	64,981,290	25,022	2,069,634
民國103年度	FY 2014	3,098,137	70,702,817	3,005,973	66,230,222	32,645	3,324,245
民國104年度	FY 2015	3,177,942	81,454,591	3,087,289	75,689,692	26,624	4,651,618
民國105年度	FY 2016	3,169,683	79,294,537	3,077,997	74,121,987	26,016	3,536,979
民國106年度	FY 2017	3,203,560	78,253,380	3,103,387	73,520,588	27,261	3,204,568
民國107年度	FY 2018	3,255,142	74,490,820	3,144,216	70,254,266	29,128	2,956,394
民國108年度	FY 2019	3,290,959	77,650,226	3,185,975	73,496,324	30,090	3,124,809
民國109年度	FY 2020	3,560,699	80,518,005	3,447,140	74,901,291	33,908	3,588,516
民國110年度	FY 2021	3,355,699	79,808,526	3,245,484	75,013,633	34,982	2,939,105
民國111年度	FY 2022	3,370,835	79,444,810	3,266,961	74,803,052	33,701	2,857,885
地價稅 Land Value Tax		940,522	28,835,605	899,720	27,604,341	4,815	471,794
土地增值稅 Land Value Increment Tax		61,431	19,025,353	56,533	16,628,333	3,461	1,889,329
房屋稅 House Tax		1,109,887	16,503,570	1,094,649	16,128,947	5,178	37,566
使用牌照稅 Vehicle License Tax		1,051,955	7,640,596	1,026,810	7,288,546	10,274	252,612
契稅 Deed Tax		41,437	1,825,354	38,982	1,732,245	1,933	76,760
印花稅 Stamp Tax		136,445	5,482,524	125,890	5,321,698	7,113	121,160
娛樂稅 Amusement Tax		22,449	93,646	21,328	87,155	363	3,609
特別稅 Special Tax Levies		-	-	-	-	-	-
臨時稅 Provisional Tax Levies		-	-	-	-	-	-
罰鍰 Fines		6,709	38,161	3,049	11,787	564	5,054

Table 3-10 The Management of Opening Collection for Assessed (Verified)
and of Tax Not Collected (Cont.3)

A. Current Fiscal Year

Unit : Case : NT\$1,000

逾徵收期間數 Overdue (4)		逾執行期間數 Exceeded Compulsory Execution Period (5)		逾核課期間數 Excess Assessment (6)		未徵數餘額 Balance of Tax Not Collected (7)=(8)+(9)+(10)+(11)+(12)+(13)	
件數 Cases	金額 Amount	件數 Cases	金額 Amount	件數 Cases	金額 Amount	件數 Cases	金額 Amount
-	-	-	-	13	58	61,818	1,412,034
-	-	-	-	9	141	59,510	1,148,209
-	-	-	-	7	101	64,022	1,113,179
-	-	-	-	4	30	65,666	1,635,541
-	-	-	-	8	47	72,904	1,528,177
-	-	-	-	6	5	81,792	1,280,155
-	-	-	-	3	14	74,891	1,029,079
-	-	-	-	11	36	79,640	2,028,163
-	-	-	-	10	41	75,223	1,855,747
-	-	-	-	8	80	70,165	1,783,794
-	-	-	-	4	50	35,983	759,420
-	-	-	-	-	-	1,437	507,691
-	-	-	-	1	11	10,059	337,045
-	-	-	-	3	18	14,868	99,420
-	-	-	-	-	-	522	16,349
-	-	-	-	-	-	3,442	39,666
-	-	-	-	-	-	758	2,882
-	-	-	-	-	-	-	-
-	-	-	-	-	-	-	-
-	-	-	-	-	-	3,096	21,320

表 3-10 查(核)定開徵數、未徵數情形(續4)

一、本年度(續1)

單位：件；新臺幣千元

會計年度及稅目別 Fiscal Year & Item of Tax		未 徵 數 餘 額					
		繳款書未送達未徵數		未逾限繳日未徵數		行政救濟未徵數	
		Have not Been Served the Payment Notice (8)		Have Not Exceeded the Deadline of Payment (9)		Aministrative Remedies (10)	
		件數 Cases	金額 Amount	件數 Cases	金額 Amount	件數 Cases	金額 Amount
民國102年度	FY 2013	28,370	668,134	15,015	430,539	96	70,784
民國103年度	FY 2014	27,334	299,768	14,530	499,542	89	115,982
民國104年度	FY 2015	28,309	222,583	16,100	595,051	164	123,635
民國105年度	FY 2016	26,180	360,430	17,003	842,333	189	116,744
民國106年度	FY 2017	28,953	394,475	19,543	660,822	159	240,328
民國107年度	FY 2018	27,639	330,952	18,799	533,119	67	101,141
民國108年度	FY 2019	27,022	271,433	20,397	478,767	55	49,448
民國109年度	FY 2020	31,325	255,973	24,086	1,300,425	53	5,131
民國110年度	FY 2021	29,289	292,619	23,494	1,085,846	42	1,314
民國111年度	FY 2022	31,399	360,643	19,387	950,585	59	13,812
地價稅 Land Value Tax		27,554	178,248	7,354	377,649	31	7,162
土地增值稅 Land Value Increment Tax		892	163,052	540	342,324	2	410
房屋稅 House Tax		1,393	8,203	4,089	160,225	23	4,149
使用牌照稅 Vehicle License Tax		1,003	6,792	2,999	13,896	-	-
契稅 Deed Tax		44	1,337	474	14,992	-	-
印花稅 Stamp Tax		176	2,174	3,264	37,487	-	-
娛樂稅 Amusement Tax		240	311	161	288	1	178
特別稅 Special Tax Levies		-	-	-	-	-	-
臨時稅 Provisional Tax Levies		-	-	-	-	-	-
罰鍰 Fines		97	525	506	3,725	2	1,912

Table 3-10 The Management of Opening Collection for Assessed (Verified)
and of Tax Not Collected (Cont.4)

A. Current Fiscal Year (Cont.1)

Unit : Case : NT\$1,000

Balance of Tax Not Collected							
分期繳納 未徵數		特殊原因未徵數		欠稅數		送達未逾滯納期欠稅數	
Pay by Stages (11)		Special Reason (12)		Tax in Arrears (13)=(14)+...+(20)		Delivery of Notice not yet Exceeded Delinquency Period (14)	
件數 Cases	金額 Amount	件數 Cases	金額 Amount	件數 Cases	金額 Amount	件數 Cases	金額 Amount
-	-	232	124	18,105	242,454	2,021	16,523
-	-	231	230	17,326	232,689	1,909	71,693
-	-	257	105	19,192	171,805	4,480	37,935
46	28,311	178	155	22,070	287,570	3,964	36,760
4	648	211	250	24,034	231,654	5,018	43,173
-	-	202	487	35,085	314,456	3,922	31,394
2	24	295	480	27,120	228,927	2,659	20,803
140	258,356	192	142	23,844	208,136	2,363	22,728
141	263,325	194	184	22,063	212,459	3,355	28,013
164	289,766	202	229	18,954	168,759	2,390	18,929
40	144,942	13	13	991	51,406	283	7,308
-	-	-	-	3	1,904	-	-
89	143,079	115	28	4,350	21,362	839	2,933
11	84	64	157	10,791	78,492	864	6,664
-	-	-	-	4	21	-	-
-	-	-	-	2	4	-	-
24	1,661	7	1	325	443	78	118
-	-	-	-	-	-	-	-
-	-	-	-	-	-	-	-
-	-	3	31	2,488	15,127	326	1,906

表 3-10 查(核)定開徵數、未徵數情形(續5)

一、本年度(續2完)

單位：件；新臺幣千元

會計年度及稅目別 Fiscal Year & Item of Tax		未徵數餘額					
		欠稅數					
		待移送執行		移送執行未結		取得執行憑證數	
		Pending for Compulsory Execution (15)		Pending Case Under Compulsory Execution (16)		Not Yet Exceeded Collection Period (17)	
		件數 Cases	金額 Amount	件數 Cases	金額 Amount	件數 Cases	金額 Amount
民國102年度	FY 2013	3,570	116,703	11,911	104,187	603	
民國103年度	FY 2014	1,904	39,649	12,504	111,676	1,007	
民國104年度	FY 2015	2,900	45,142	11,249	84,569	563	
民國105年度	FY 2016	3,052	131,993	14,143	111,609	910	
民國106年度	FY 2017	3,207	74,005	15,026	110,325	783	4,151
民國107年度	FY 2018	5,051	116,123	24,056	158,322	2,054	8,617
民國108年度	FY 2019	3,884	67,005	19,374	133,998	1,202	7,120
民國109年度	FY 2020	2,703	53,914	17,543	124,229	1,234	7,265
民國110年度	FY 2021	3,706	77,717	13,823	99,483	1,176	7,246
民國111年度	FY 2022	1,948	50,088	13,313	91,488	1,303	8,254
地價稅 Land Value Tax		578	43,138	130	960	-	-
土地增值稅 Land Value Increment Tax		-	-	3	1,904	-	-
房屋稅 House Tax		487	1,429	3,012	16,899	12	101
使用牌照稅 Vehicle License Tax		731	4,700	8,444	62,349	752	4,779
契稅 Deed Tax		4	21	-	-	-	-
印花稅 Stamp Tax		-	-	2	4	-	-
娛樂稅 Amusement Tax		27	26	198	280	22	19
特別稅 Special Tax Levies		-	-	-	-	-	-
臨時稅 Provisional Tax Levies		-	-	-	-	-	-
罰鍰 Fines		121	775	1,524	9,091	517	3,356

表 3-10 查(核)定開徵數、未徵數情形(續6)

二、以前年度

單位：件；新臺幣千元

會計年度及稅目別 Fiscal Year & Item of Tax		查(核)定開徵數		實徵數		減免註銷數	
		Opening Collection for Assessed (Verified) (1)=(2)+(3)+(4)+(5)+(6)+(7)		Tax Collected (2)		Cancelled (3)	
		件數 Cases	金額 Amount	件數 Cases	金額 Amount	件數 Cases	金額 Amount
民國102年度	FY 2013	168,974	3,016,747	76,703	1,146,773	478	75,169
民國103年度	FY 2014	149,916	2,911,044	69,114	947,241	-861	81,493
民國104年度	FY 2015	137,313	2,840,678	67,316	1,027,413	-523	25,530
民國105年度	FY 2016	134,592	2,793,072	67,836	1,132,222	-6	62,161
民國106年度	FY 2017	142,332	3,222,246	70,997	1,385,485	-2,281	180,311
民國107年度	FY 2018	156,472	3,135,881	76,590	1,554,016	-3,177	-44,324
民國108年度	FY 2019	176,459	2,895,449	83,312	1,246,741	-3,816	85,588
民國109年度	FY 2020	182,320	2,570,399	88,715	1,011,448	-7,743	-82,157
民國110年度	FY 2021	192,238	3,667,147	94,873	1,756,067	-10,757	-143,861
民國111年度	FY 2022	195,809	3,885,458	90,779	1,920,629	-9,111	6,114
地價稅 Land Value Tax		55,990	1,577,407	36,533	895,268	267	15,621
土地增值稅 Land Value Increment Tax		1,248	857,754	1,004	400,625	181	108,169
房屋稅 House Tax		18,064	513,817	12,340	319,052	198	1,704
使用牌照稅 Vehicle License Tax		77,528	459,722	20,515	94,443	-152	87
契稅 Deed Tax		869	30,202	764	25,784	94	4,186
印花稅 Stamp Tax		4,871	44,209	14,321	166,440	-9,526	-123,781
娛樂稅 Amusement Tax		5,807	17,529	1,229	2,395	-216	-190
特別稅 Special Tax Levies		-	-	-	-	-	-
臨時稅 Provisional Tax Levies		-	-	-	-	-	-
罰鍰 Fines		31,432	384,819	4,073	16,621	43	319

Table 3-10 The Management of Opening Collection for Assessed (Verified)
and of Tax Not Collected (Cont.6)

B. Previous Fiscal Years

Unit : Case : NT\$1,000

逾徵收期間數 Overdue (4)		逾執行期間數 Exceeded Compulsory Execution Period (5)		逾核課期間數 Excess Assessment (6)		未徵數餘額 Balance of Tax Not Collected (7)=(8)+(9)+(10)+(11)+(12)+(13)	
件數 Cases	金額 Amount	件數 Cases	金額 Amount	件數 Cases	金額 Amount	件數 Cases	金額 Amount
13,596	117,944	-	-	295	4,124	77,902	1,672,737
14,123	120,263	-	-	282	10,341	67,258	1,751,706
9,820	101,197	-	-	313	7,896	60,387	1,678,641
795	1,480	-	-	267	3,703	65,700	1,593,507
340	841	214	30,743	238	3,198	72,824	1,621,669
206	205	28	669	243	11,451	82,582	1,613,864
163	113	3	49	235	3,128	96,562	1,559,831
153	275	-	-	238	2,919	100,957	1,637,915
156	333	28	11,371	262	3,674	107,676	2,039,562
134	241	145	33,020	227	3,136	113,635	1,922,319
85	15	34	13,259	186	2,956	18,885	650,289
-	-	-	-	-	-	63	348,961
15	3	29	18,864	3	3	5,479	174,192
27	56	74	582	37	167	57,027	364,386
-	-	-	-	-	-	11	232
-	-	-	-	-	-	76	1,550
1	1	-	-	-	-	4,793	15,323
-	-	-	-	-	-	-	-
-	-	-	-	-	-	-	-
6	166	8	317	1	10	27,301	367,386

表 3-10 查(核)定開徵數、未徵數情形(續7)

二、以前年度(續1)

單位：件；新臺幣千元

會計年度及稅目別 Fiscal Year & Item of Tax		未徵數餘額					
		繳款書未送達未徵數		未逾限繳日未徵數		行政救濟未徵數	
		Have not Been Served the Payment Notice (8)		Have Not Exceeded the Deadline of Payment (9)		Aministrative Remedies (10)	
		件數 Cases	金額 Amount	件數 Cases	金額 Amount	件數 Cases	金額 Amount
民國102年度	FY 2013	672	63,134	157	2,656	206	64,554
民國103年度	FY 2014	721	47,788	275	234,801	197	37,379
民國104年度	FY 2015	638	19,240	342	298,214	28	61,213
民國105年度	FY 2016	660	21,573	106	2,880	112	158,663
民國106年度	FY 2017	698	16,285	316	17,514	56	157,365
民國107年度	FY 2018	576	18,555	192	22,633	100	93,398
民國108年度	FY 2019	610	20,242	73	11,769	13	27,066
民國109年度	FY 2020	611	15,990	90	22,485	12	76,029
民國110年度	FY 2021	619	19,308	220	268,633	5	54,998
民國111年度	FY 2022	670	14,107	226	52,302	51	53,621
地價稅 Land Value Tax		565	8,769	173	1,936	2	8,856
土地增值稅 Land Value Increment Tax		20	3,866	4	16,768	-	-
房屋稅 House Tax		22	45	35	33,543	48	187
使用牌照稅 Vehicle License Tax		4	31	11	43	-	-
契稅 Deed Tax		1	6	1	2	-	-
印花稅 Stamp Tax		58	1,390	-	-	-	-
娛樂稅 Amusement Tax		-	-	-	-	-	-
特別稅 Special Tax Levies		-	-	-	-	-	-
臨時稅 Provisional Tax Levies		-	-	-	-	-	-
罰鍰 Fines		-	-	2	10	1	44,579

Table 3-10 The Management of Opening Collection for Assessed (Verified)
and of Tax Not Collected (Cont.7)

B. Previous Fiscal Years (Cont.1)

Unit : Case : NT\$1,000

Balance of Tax Not Collected							
分期繳納 未徵數		特殊原因未徵數		欠稅數		送達未逾滯納期欠稅數	
Pay by Stages (11)		Special Reason (12)		Tax in Arrears (13)=(14)+...+(20)		Delivery of Notice not yet Exceeded Delinquency Period (14)	
件數 Cases	金額 Amount	件數 Cases	金額 Amount	件數 Cases	金額 Amount	件數 Cases	金額 Amount
-	-	4,512	24,114	72,264	1,517,626	30	364
-	-	3,713	20,956	62,352	1,410,783	66	584
-	-	3,049	20,599	56,330	1,279,375	94	2,095
-	-	2,054	4,056	62,768	1,406,336	63	365
-	-	1,707	3,933	70,047	1,426,572	71	490
-	-	1,826	4,094	79,888	1,475,184	68	730
-	-	1,842	4,458	94,024	1,496,297	53	874
-	-	1,726	4,244	98,518	1,519,167	39	396
91	144,247	1,665	3,773	105,076	1,548,603	75	612
184	205,108	1,681	3,527	110,823	1,593,654	62	1,040
20	122,805	1,152	2,387	16,973	505,537	54	419
1	70	-	-	38	328,258	3	578
127	80,939	216	49	5,031	59,429	1	11
6	43	257	767	56,749	363,502	4	32
-	-	-	-	9	224	-	-
-	-	-	-	18	159	-	-
30	1,251	25	4	4,738	14,067	-	-
-	-	-	-	-	-	-	-
-	-	-	-	-	-	-	-
-	-	31	320	27,267	322,478	-	-

表 3-10 查(核)定開徵數、未徵數情形(續8完)

二、以前年度(續2完)

單位：件；新臺幣千元

會計年度及稅目別 Fiscal Year & Item of Tax		未徵數餘額					
		欠稅數					
		待移送執行		移送執行未結		取得執行憑證數	
		Pending for Compulsory Execution (15)		Pending Case Under Compulsory Execution (16)		Not Yet Exceeded Collection Period (17)	
		件數 Cases	金額 Amount	件數 Cases	金額 Amount	件數 Cases	金額 Amount
民國102年度	FY 2013	86	1,058	14,025	952,511	58,119	563,693
民國103年度	FY 2014	104	984	13,012	912,598	49,093	496,408
民國104年度	FY 2015	128	4,240	12,404	856,384	43,632	416,342
民國105年度	FY 2016	129	762	14,706	849,014	47,807	555,974
民國106年度	FY 2017	160	2,411	18,948	870,600	29,967	272,443
民國107年度	FY 2018	134	1,475	21,464	878,767	33,025	280,791
民國108年度	FY 2019	166	1,484	22,645	821,485	42,765	329,534
民國109年度	FY 2020	129	1,053	17,636	761,729	49,739	391,862
民國110年度	FY 2021	241	3,820	15,532	693,189	43,101	282,860
民國111年度	FY 2022	230	28,835	13,692	519,031	43,407	294,126
地價稅 Land Value Tax		185	28,625	5,176	121,045	5,204	58,109
土地增值稅 Land Value Increment Tax		2	52	13	320,305	7	1,248
房屋稅 House Tax		33	90	1,545	18,666	1,485	6,403
使用牌照稅 Vehicle License Tax		9	66	4,466	35,050	22,370	134,789
契稅 Deed Tax		-	-	-	-	-	-
印花稅 Stamp Tax		-	-	11	35	-	-
娛樂稅 Amusement Tax		-	-	247	1,092	1,278	2,027
特別稅 Special Tax Levies		-	-	-	-	-	-
臨時稅 Provisional Tax Levies		-	-	-	-	-	-
罰鍰 Fines		1	1	2,234	22,838	13,063	91,549

Table 3-10 The Management of Opening Collection for Assessed (Verified)
and of Tax Not Collected (Cont.8 End)

B. Previous Fiscal Years (Cont.2 End)

Unit : Case ; NT\$1,000

Balance of Tax Not Collected					
Tax in Arrears					
Execution Certificate		移送執行結(銷)案		無法執行欠稅數	
已逾徵收期間惟未逾執行期間 Exceeded Collection Period Not Yet Exceeded Compulsory Execution Period (18)		Cases Closed Under Compulsory Execution (19)		Unable to Carry out Compulsory Execution (20)	
件數 Cases	金額 Amount	件數 Cases	金額 Amount	件數 Cases	金額 Amount
-	-	4	-	91	653
-	-	6	0	71	209
-	-	8	105	64	208
-	-	9	13	54	207
20,851	280,618	5	5	45	5
25,150	313,392	15	26	32	4
28,350	342,913	3	1	42	5
30,922	364,118	7	2	46	5
46,075	568,116	3	0	49	6
53,351	750,614	22	0	59	8
6,322	297,334	-	-	32	4
13	6,074	-	-	-	-
1,957	34,257	1	0	9	1
29,871	193,563	20	0	9	1
9	224	-	-	-	-
7	124	-	-	-	-
3,213	10,948	-	-	-	-
-	-	-	-	-	-
-	-	-	-	-	-
11,959	208,088	1	0	9	2

表 3-11 違章漏稅案件處理及財務罰鍰執行情形

單位：件；新臺幣千元

會計年度及稅目別 Fiscal Year & Item of Tax		受理情形 Cases Accepted			本期審理情形 Interrogated in This Term					
		合計 Total (1)	上期未 結件數 No. of Pending of Last Term (2)	本期受 理件數 No. of Accepted in This Term (3)	依法免 議件數 No. of Not Indictable by Law (4)	依法免 罰件數 No. of Fine Free (5)	依法併 案件數 No. of Consolidated (6)	依法註 銷件數 No. of Cancelled (7)	處罰 Fined	
									件數 No. (8)	金額 Amount (9)
民國101年度	FY 2012	6,042	72	5,970	382	726	-	-	4,890	81,560
民國102年度	FY 2013	5,635	44	5,591	289	387	-	-	4,898	68,455
民國103年度	FY 2014	3,597	61	3,536	221	268	-	-	3,080	49,005
民國104年度	FY 2015	6,958	28	6,930	193	559	-	-	6,087	40,910
民國105年度	FY 2016	9,103	119	8,984	204	1,761	-	-	7,020	43,564
民國106年度	FY 2017	17,677	118	17,559	204	4,732	-	-	12,692	64,583
民國107年度	FY 2018	21,358	49	21,309	1,616	4,296	-	-	15,252	81,174
民國108年度	FY 2019 [◎]	11,916	212	11,704	-	1,251	-	194	10,445	99,323
民國109年度	FY 2020	10,456	26	10,430	16	1,366	-	141	8,898	50,159
民國110年度	FY 2021	9,298	35	9,263	23	1,319	-	57	7,879	48,547
地價稅 Land Value Tax		4	-	4	-	-	-	-	4	68
土地增值稅 Land Value Increment Tax		-	-	-	-	-	-	-	-	-
房屋稅 House Tax		20	1	19	3	-	-	1	16	3,227
使用牌照稅 Vehicle License Tax		9,262	34	9,228	20	1,317	-	56	7,849	42,242
契稅 Deed Tax		-	-	-	-	-	-	-	-	-
印花稅 Stamp Tax		2	-	2	-	-	-	-	2	2,942
娛樂稅 Amusement Tax		10	-	10	-	2	-	-	8	68
特別稅 Special Tax Levies		-	-	-	-	-	-	-	-	-
臨時稅 Provisional Tax Levies		-	-	-	-	-	-	-	-	-

資料來源：依據本處稅務管理科報表20903-90-03編製，103年度以前表號為2613-90-01。

說明：◎108年度公務統計方案修訂，本表原項目「依法免議件數」拆分為「依法免議件數」、「依法併案件數」、「依法註銷件數」，107年度以前依法免議件數含依法併案及依法註銷件數。

Table 3-11 The Management of Tax Evasion Law and Execution Status of Fine

Unit : Case ; NT\$1,000

未結件數 No. of Pending (10)	本期繳納及移送強制執行情形 Fine Paid and Transferred to Administrative Enforcement Agency in This Term						更正註銷案件 Revised or Cancelled	
	合計 Total		自行繳納 Paid Voluntarily		移送執行 Transferred to Execute		件數 No. (17)	金額 Amount (18)
	件數 No. (11)	金額 Amount (12)	件數 No. (13)	金額 Amount (14)	件數 No. (15)	金額 Amount (16)		
44	11,727	178,053	4,092	23,740	7,635	154,313	-3,553	1,865
61	11,152	162,532	3,543	27,326	7,609	135,206	6	33,485
28	7,755	131,268	1,671	11,301	6,084	119,967	1,783	35,519
119	5,805	85,539	796	3,118	5,009	82,421	2,093	57,071
118	7,440	93,590	1,007	1,670	6,433	91,920	15	419
49	6,740	61,607	1,346	1,248	5,394	60,359	11	158
194	16,375	103,070	2,692	1,247	13,683	101,823	5	17
26	15,450	108,709	4,042	17,140	11,408	91,568	287	2,674
35	15,165	128,396	3,464	15,498	11,701	112,898	314	3,098
20	12,837	103,766	2,991	18,423	9,846	85,344	353	2,317
-	4	173	4	173	-	-	-	-
-	-	-	-	-	-	-	-	-
-	15	2,899	14	2,862	1	37	-	-
20	12,808	97,685	2,964	12,385	9,844	85,299	351	2,312
-	-	-	-	-	-	-	-	-
-	2	2,942	2	2,942	-	-	2	6
-	8	68	7	60	1	8	-	-
-	-	-	-	-	-	-	-	-
-	-	-	-	-	-	-	-	-

說明：②108年度因資料產出平台轉換，致上期未結件數不等於107年度未結件數。

③108年度公務統計方案修訂，本表原項目「移送駁回或撤回」拆分為「撤案」、「退案」、「結案」，並依據稅務管理科提供之表報代號WXM510P資料回溯100年度至107年度。

表 3-11 違章漏稅案件處理及財務罰鍰執行情形 (續1完)

單位：件；新臺幣千元

會計年度及稅目別 Fiscal Year & Item of Tax		本期執行情形 Executed in This Term					
		合計		移送繳納		發給執行憑證	
		Total		Fined Paid		Giving Execution Evidence	
		件數 No. (19)	金額 Amount (20)	件數 No. (21)	金額 Amount (22)	件數 No. (23)	金額 Amount (24)
民國101年度	FY 2012	6,560	150,690	1,816	32,995	4,616	114,427
民國102年度	FY 2013	6,996	136,684	1,938	29,024	4,976	105,960
民國103年度	FY 2014	6,881	127,183	1,877	28,647	4,927	97,115
民國104年度	FY 2015	5,540	118,027	1,376	21,416	4,129	95,819
民國105年度	FY 2016	5,360	80,991	1,560	16,011	3,763	64,543
民國106年度	FY 2017	4,971	72,232	1,677	12,953	3,184	58,151
民國107年度	FY 2018	8,260	76,826	3,150	15,947	5,010	60,177
民國108年度	FY 2019	11,405	95,737	4,281	22,114	7,059	72,743
民國109年度	FY 2020	12,013	119,268	4,107	22,625	7,865	96,238
民國110年度	FY 2021	10,573	96,596	2,987	18,102	7,566	78,373
地價稅 Land Value Tax		-	-	-	-	-	-
土地增值稅 Land Value Increment Tax		-	1,429	-	1,429	-	-
房屋稅 House Tax		1	37	1	37	-	-
使用牌照稅 Vehicle License Tax		10,570	94,981	2,986	16,636	7,564	78,224
契稅 Deed Tax		-	-	-	-	-	-
印花稅 Stamp Tax		1	0	-	-	1	0
娛樂稅 Amusement Tax		1	149	-	0	1	149
特別稅 Special Tax Levies		-	-	-	-	-	-
臨時稅 Provisional Tax Levies		-	-	-	-	-	-

表 3-12 各項稅捐稽徵成本統計

單位：新臺幣元

會計年度及稅目別 Fiscal Year & Item of Tax	實徵淨額 (千元) Net Actual Collection (NT\$1,000) (1)	成本總計 Grand Total Cost (2)=(3)+(4)	合計 Total (3)	直接成本 Direct Cost	
				人事費 Personnel Expenses	業務費(『稅捐稽徵業務』業務計畫) Affair Expenses (Sales Plan for Taxation Business)
民國101年度 FY 2012	62,189,138	893,122,419	737,611,087	649,168,890	86,245,674
民國102年度 FY 2013	66,310,719	904,340,532	748,714,945	655,320,157	90,449,214
民國103年度 FY 2014	67,291,124	915,806,028	761,007,477	657,895,945	100,812,463
民國104年度 FY 2015	76,823,364	915,744,460	755,785,803	657,066,421	95,965,105
民國105年度 FY 2016	75,321,811	909,238,030	649,578,524	556,033,907	91,202,658
民國106年度 FY 2017	74,888,860	909,823,616	659,351,947	570,084,120	86,740,199
民國107年度 FY 2018	71,814,731	952,598,068	699,345,739	581,948,515	114,709,567
民國108年度 FY 2019	74,641,092	934,424,003	689,483,886	591,149,588	95,481,869
民國109年度 FY 2020	75,751,447	939,834,879	696,077,436	595,312,104	99,344,314
民國110年度 FY 2021	76,686,228	941,061,958	696,286,274	594,836,846	100,896,042
地價稅 Land Value Tax	27,139,625	263,530,922	194,944,775	166,673,285	28,271,070
土地增值稅 Land Value Increment Tax	18,824,195	191,111,647	141,373,228	120,870,847	20,502,076
房屋稅 House Tax	15,787,280	265,129,789	196,127,524	167,684,507	28,442,594
使用牌照稅 Vehicle License Tax	7,389,903	111,732,596	82,653,245	70,666,617	11,986,450
契稅 Deed Tax	1,989,315	44,015,871	32,560,369	27,838,364	4,721,935
印花稅 Stamp Tax	5,494,866	38,090,658	28,177,243	24,090,892	4,086,290
娛樂稅 Amusement Tax	61,044	27,450,475	20,449,890	17,012,334	2,885,627
特別稅 Special Tax Levies	-	-	-	-	-
臨時稅 Provisional Tax Levies	-	-	-	-	-

資料來源：依據本處會計室報表20903-90-05編製，103年度以前表號為2613-90-05。

說明：房屋稅、娛樂稅實徵淨額含附徵之教育捐金額。

Table 3-12 Cost of Tax Levying

Unit : N.T.\$

獎補助 及損失 Incentives, Subsidies and Losses	合計 Total (4)	間接成本 Indirect Cost				每千元成本 Cost Per NT\$1,000 (5)=(2)/(1)
		人事費 Personnel Expenses	業務費(『一般 行政』業務計 畫) Affair Expenses (General Administrative Business Plan)	設備 及投資費 Equipment and Investment Costs	其他 Others	
2,196,523	155,511,332	96,562,677	42,164,889	16,783,766	—	14.36
2,945,574	155,625,587	96,512,541	40,427,764	18,685,282	—	13.64
2,299,069	154,798,551	96,348,667	40,505,314	17,944,570	—	13.61
2,754,277	159,958,657	98,462,476	39,974,977	21,521,204	—	11.92
2,341,959	259,659,506	203,723,347	37,437,650	18,498,509	—	12.07
2,527,628	250,471,669	194,101,189	38,203,252	18,167,228	—	12.15
2,687,657	253,252,329	195,255,900	39,443,508	18,552,921	—	13.26
2,852,429	244,940,117	188,766,441	40,851,804	15,321,872	—	12.52
1,421,018	243,757,443	187,815,417	37,395,727	18,546,299	—	12.41
553,386	244,775,684	184,604,539	38,893,131	21,278,014	-	12.27
420	68,586,147	51,726,192	10,897,855	5,962,100	-	9.71
305	49,738,419	37,511,643	7,903,084	4,323,692	-	10.15
423	69,002,265	52,040,019	10,963,974	5,998,272	-	16.79
178	29,079,351	21,931,019	4,620,504	2,527,828	-	15.12
70	11,455,502	8,639,492	1,820,199	995,811	-	22.13
61	9,913,415	7,476,484	1,575,171	861,760	-	6.93
551,929	7,000,585	5,279,690	1,112,344	608,551	-	449.68
-	-	-	-	-	-	-
-	-	-	-	-	-	-

表 3-13 各項稅捐滯納案件移送執行情形

單位：新臺幣元

會計年度及稅目別 Fiscal Year & Item of Tax		移送執行數①		執行徵起數 (1)		掣發債權憑證數 (2)	
		Executed cases		Executive Levied Tax		Giving Executive Evidence	
		件數 Cases	金額 Amount	件數 Cases	金額 Amount	件數 Cases	金額 Amount
民國101年度	FY 2012	55,501	546,330,038	26,548	438,195,809	25,761	262,966,626
民國102年度	FY 2013	46,641	420,820,836	26,114	331,664,615	23,141	176,463,048
民國103年度	FY 2014	44,654	411,498,960	25,496	288,609,636	20,152	162,299,899
民國104年度	FY 2015	43,075	428,150,709	26,151	300,982,249	17,003	180,861,988
民國105年度	FY 2016	48,613	683,536,545	29,212	333,979,945	15,495	298,700,331
民國106年度	FY 2017	46,480	573,372,660	29,353	377,759,399	12,038	100,871,148
民國107年度	FY 2018	55,559	553,553,848	31,219	373,480,986	15,863	118,765,416
民國108年度	FY 2019	54,086	546,744,827	36,038	501,920,898	19,387	136,430,206
民國109年度	FY 2020	57,235	514,622,155	37,893	362,907,585	21,346	181,109,186
民國110年度	FY 2021	47,943	445,448,030	30,673	317,707,189	20,748	228,751,795
地價稅 Land Value Tax		11,267	132,226,784	8,035	99,653,407	3,226	68,428,094
土地增值稅 Land Value Increment Tax		6	4,438,099	8	1,826,684	5	2,829,683
房屋稅 House Tax		7,412	53,507,947	6,301	54,891,744	1,228	28,960,342
使用牌照稅 Vehicle License Tax		27,193	195,422,462	15,506	121,046,160	14,938	97,835,901
契稅 Deed Tax		2	2,328	1	923	-	-
印花稅 Stamp Tax		9	32,714	2	4,259	-	-
娛樂稅 Amusement Tax		2,054	3,727,405	820	1,281,160	1,351	2,563,906
罰鍰② Fine		-	56,090,291	-	39,002,852	-	28,133,869

資料來源：依據本處稅務管理科報表20903-90-07、20903-90-08編製，103年度以前表號為2613-90-02、2613-90-03。

說明：①包括以前年度移送未執行結轉數。

②罰鍰係指本稅以外之短估金、滯(怠)報金、滯納金及加計利息等之合計數，為附加稅，故不計件數。

Table 3-13 The Status of Delayed Case Transferred to Execution

Unit : N.T.S

撤退結案數 ^③ (3) Numbers of the withdrawn/rejected/closed case		稅捐處清理數 ^③ (4)=(1)+(2)+(3) Numbers of the clean-up cases by the Revenue Service Office		移送尚未執行數 Unexecuted Cases	
件數 Cases	金額 Amount	件數 Cases	金額 Amount	件數 Cases	金額 Amount
1,017	14,761,965	53,326	715,924,400	42,845	1,395,183,086
520	6,656,743	49,775	514,784,406	4,307	151,801,244
318	3,398,005	45,966	454,307,540	36,989	1,234,841,497
221	6,775,138	43,375	488,619,375	35,932	1,162,575,765
249	5,579,121	44,956	638,259,397	38,910	1,171,977,797
236	4,888,263	41,627	483,518,810	42,884	1,240,273,298
165	1,774,790	47,247	494,021,192	50,929	1,290,357,391
166	2,875,626	55,591	641,226,730	48,882	1,190,038,398
200	2,239,513	59,439	546,256,284	46,410	1,159,684,845
119	6,211,217	51,540	552,670,201	42,484	1,041,931,845
31	529,914	11,292	168,611,415	8,701	310,227,324
2	3,911,100	15	8,567,467	24	321,836,732
18	632,924	7,547	84,485,010	5,491	72,920,915
66	323,604	30,510	219,205,665	26,308	184,823,951
-	-	1	923	3	113,623
-	-	2	4,259	20	177,721
2	754	2,173	3,845,820	1,937	4,142,894
-	812,921	-	67,949,642	-	147,688,685

說明：③配合102年公務統計方案修訂，將96年3月5日前移送強制執行案件，其執行期間業已屆滿5年不再執行之案件定義為「結案」，本表原項目名稱「撤退案數」自102起納入前述「結案」數並修為「撤退結案數」；亦一併將「稅捐處結案數」修為「稅捐處清理數」。

表 3-14 本處各項稅捐稽徵工作流程

(一)地 價 稅

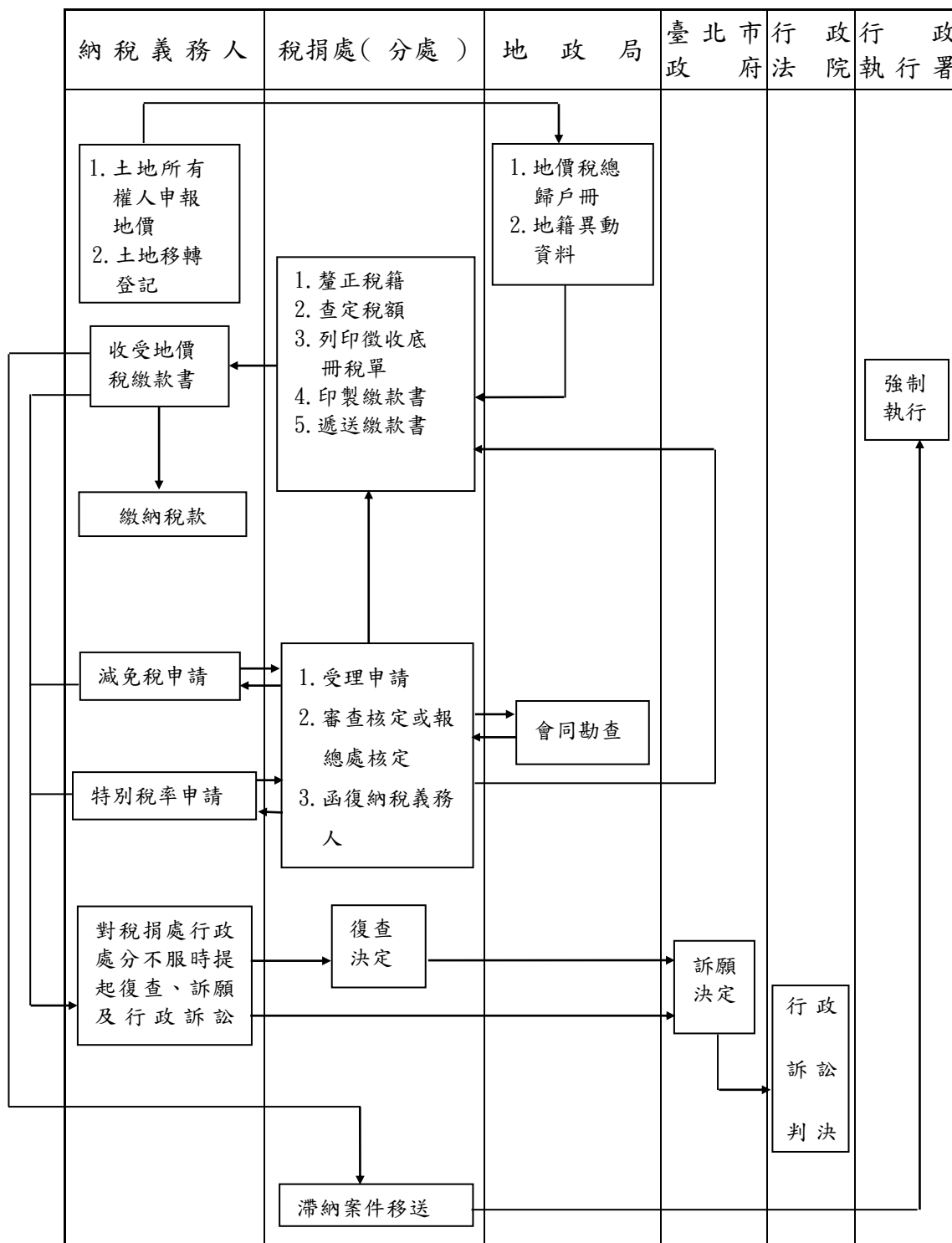

資料來源：依據本處財產稅科、機會稅科及稅務管理科資料編製。

表 3-14 本處各項稅捐稽徵工作流程 (續 1)
(二)土地增值稅



表 3-14 本處各項稅捐稽徵工作流程 (續 2)

(三)房 屋 稅



表 3-14 本處各項稅捐稽徵工作流程圖 (續 3)
(四)使用牌照稅

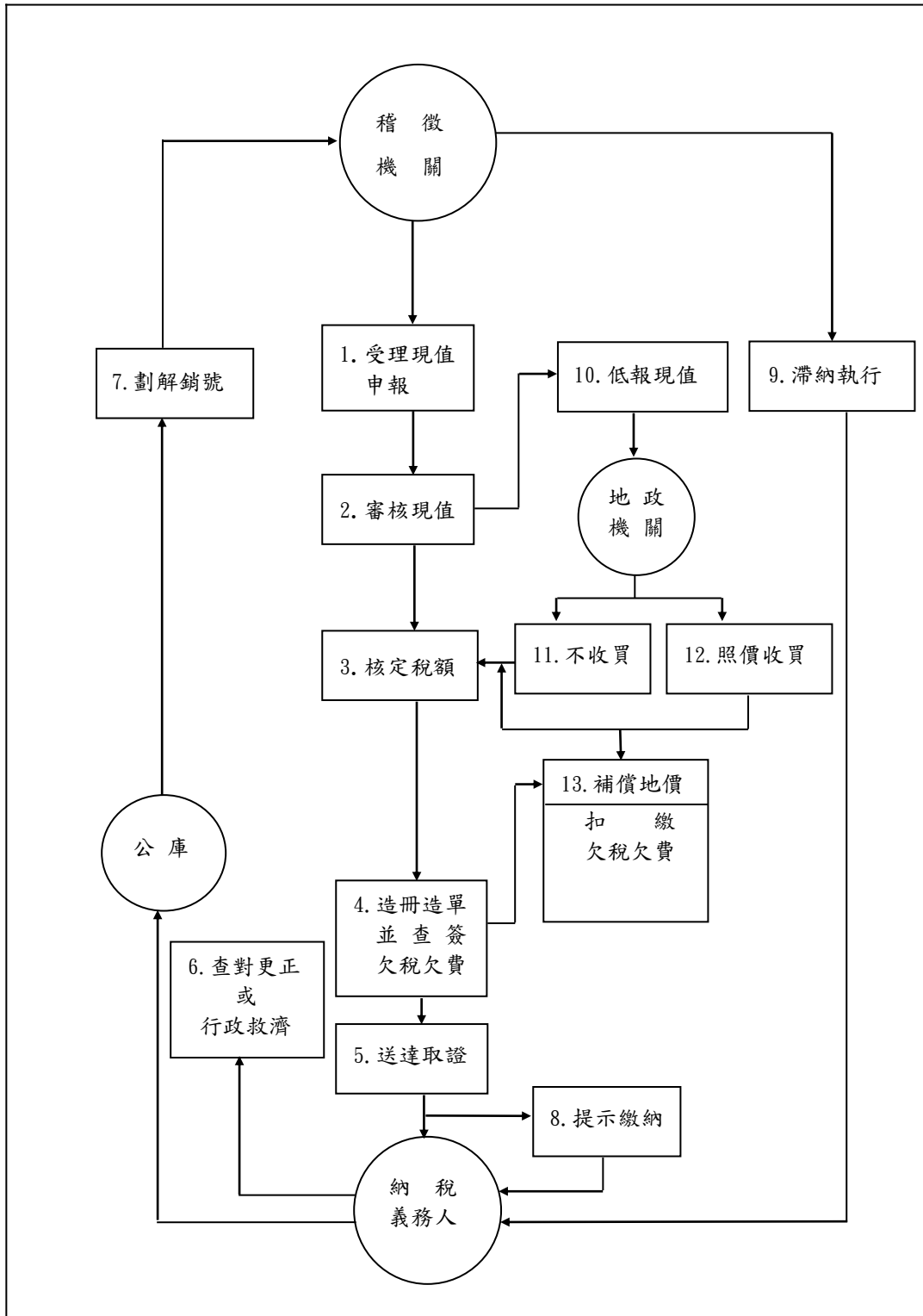

表 3-14 本處各項稅捐稽徵工作流程圖 (續 4)

(五)契 稅

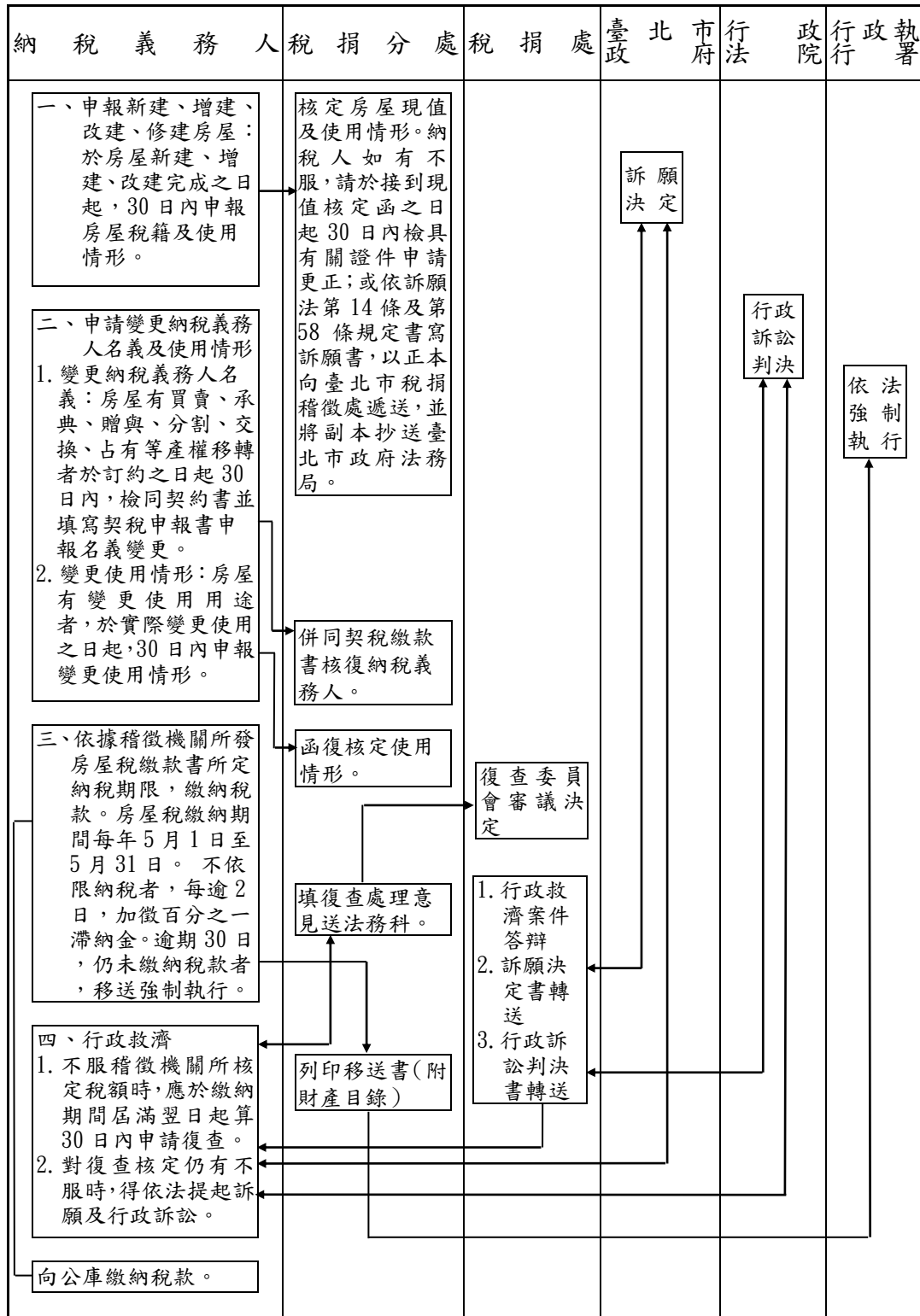

表 3-14 本處各項稅捐稽徵工作流程圖 (續 5)
(六)印 花 稅

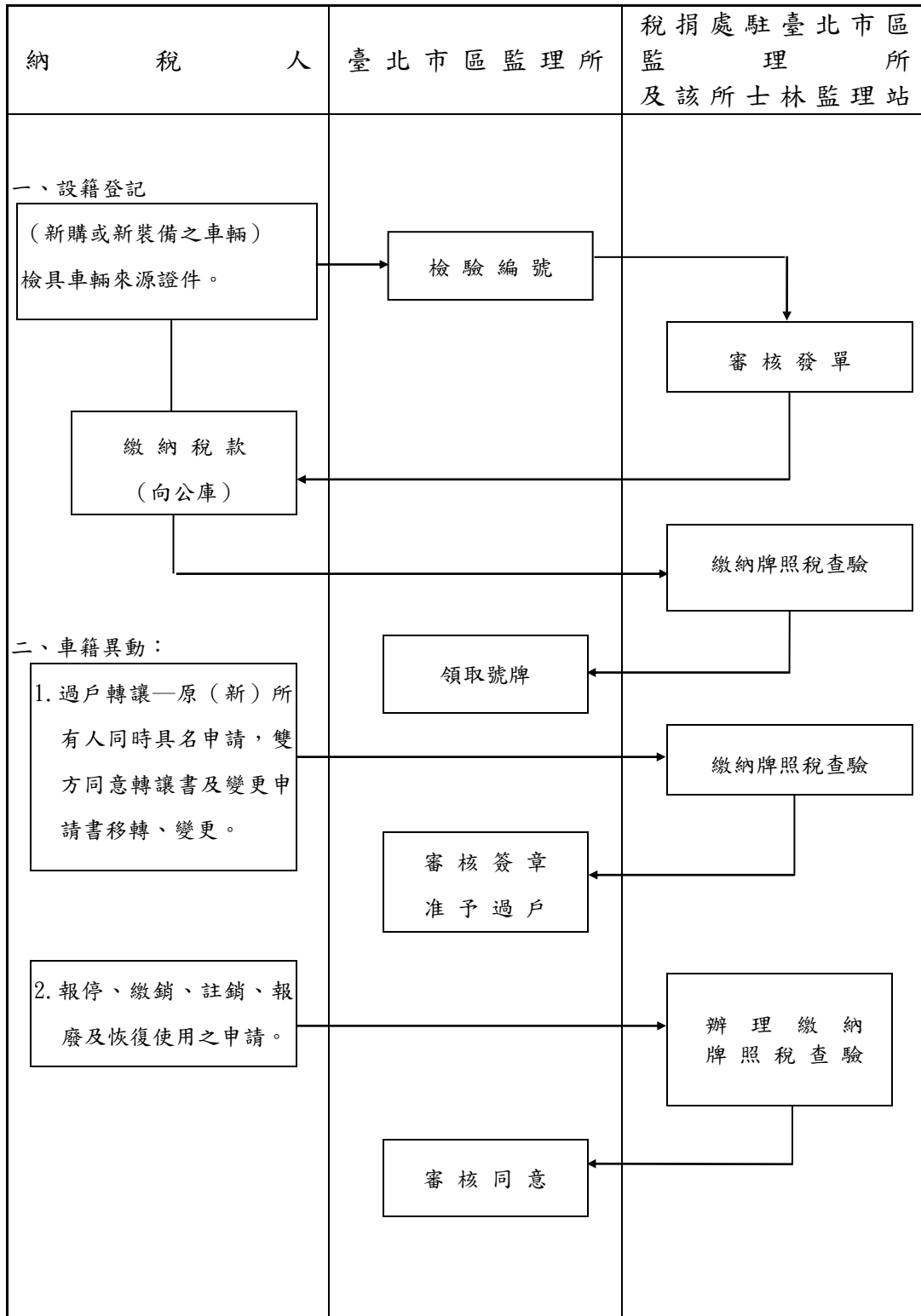

表 3-14 本處各項稅捐稽徵工作流程圖 (續 6)
(七) 娛樂稅

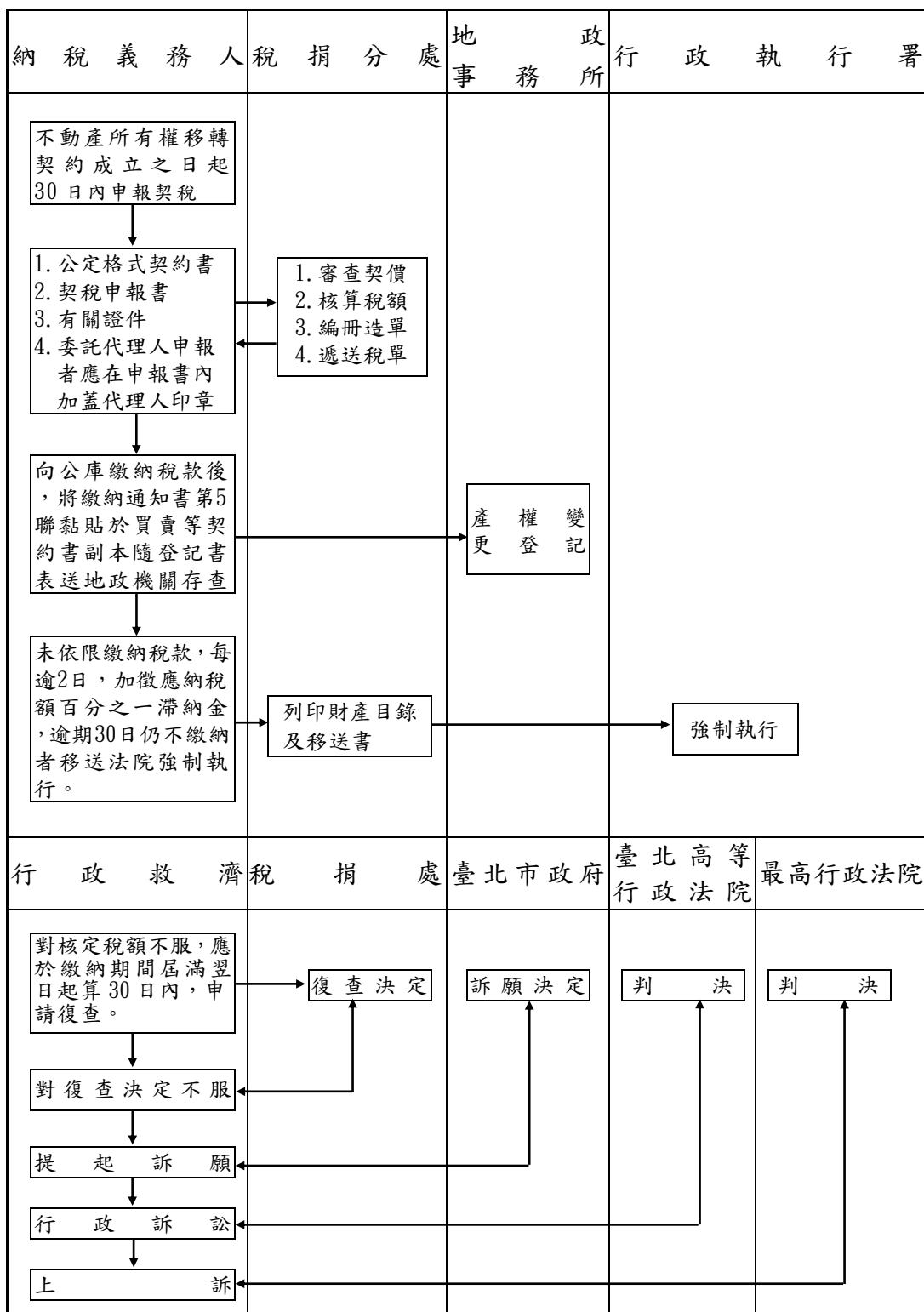

表 3-14 本處各項稅捐稽徵工作流程圖 (續 7 完)

(八) 支票退稅

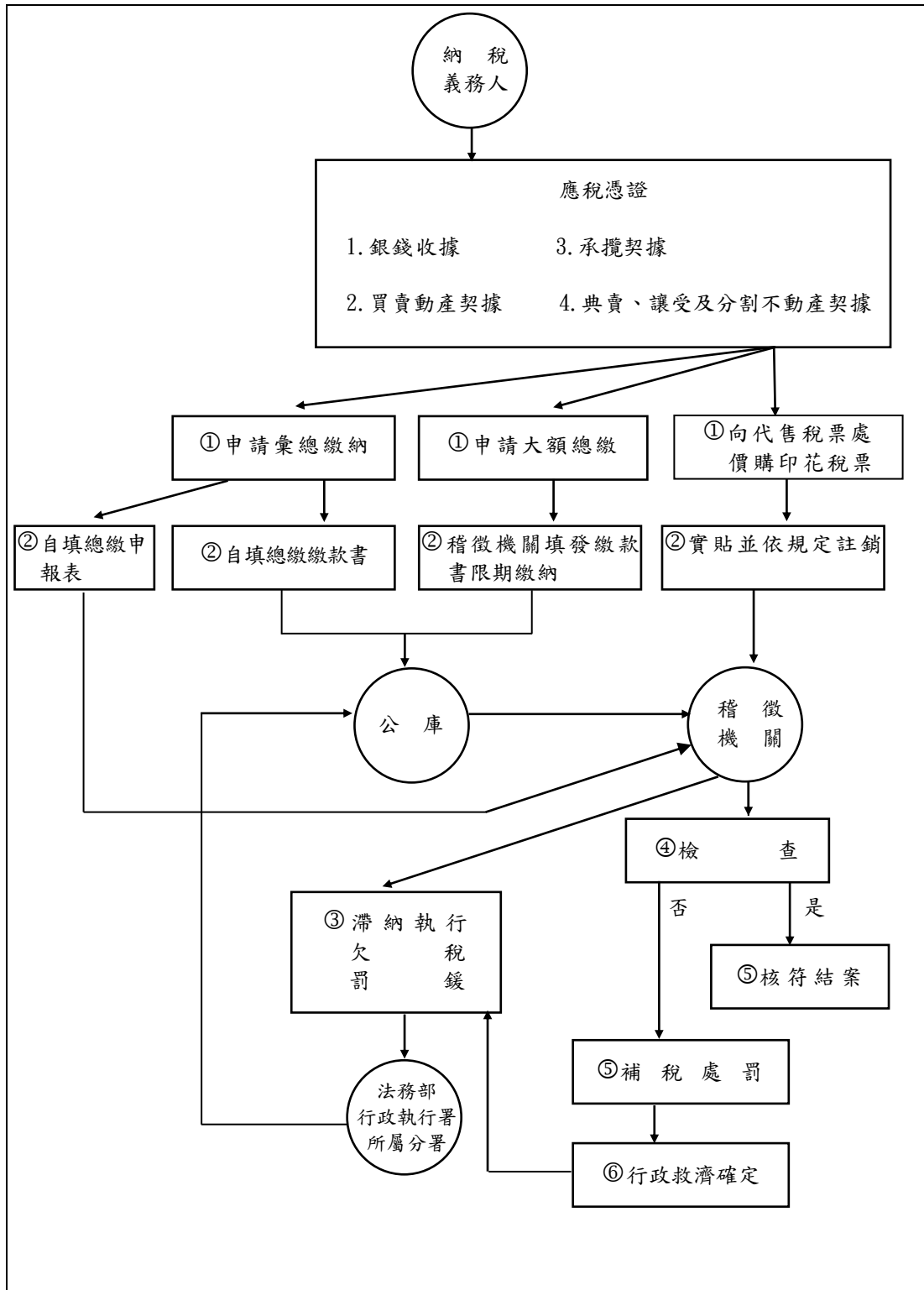

本 頁 空 白

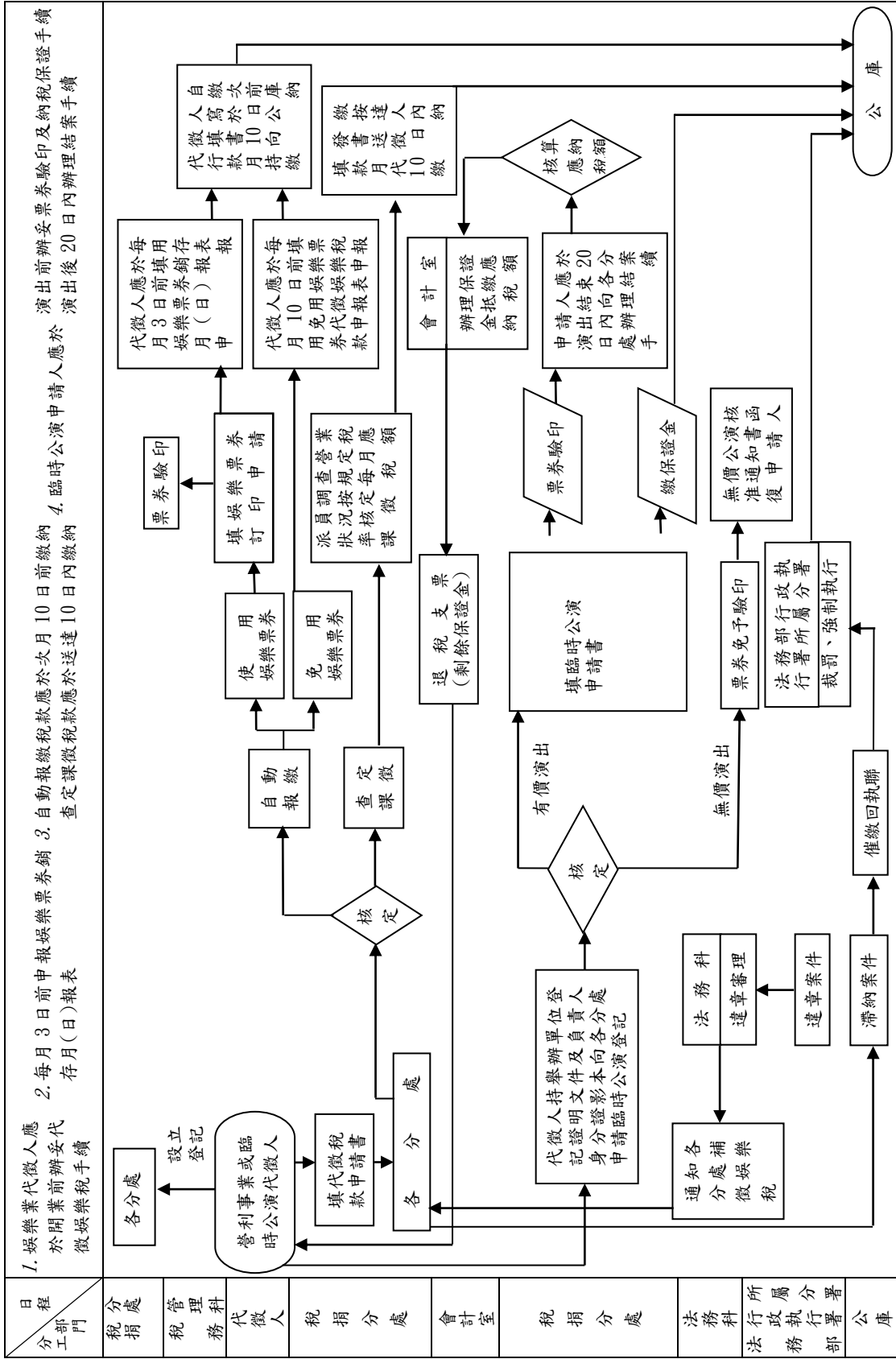
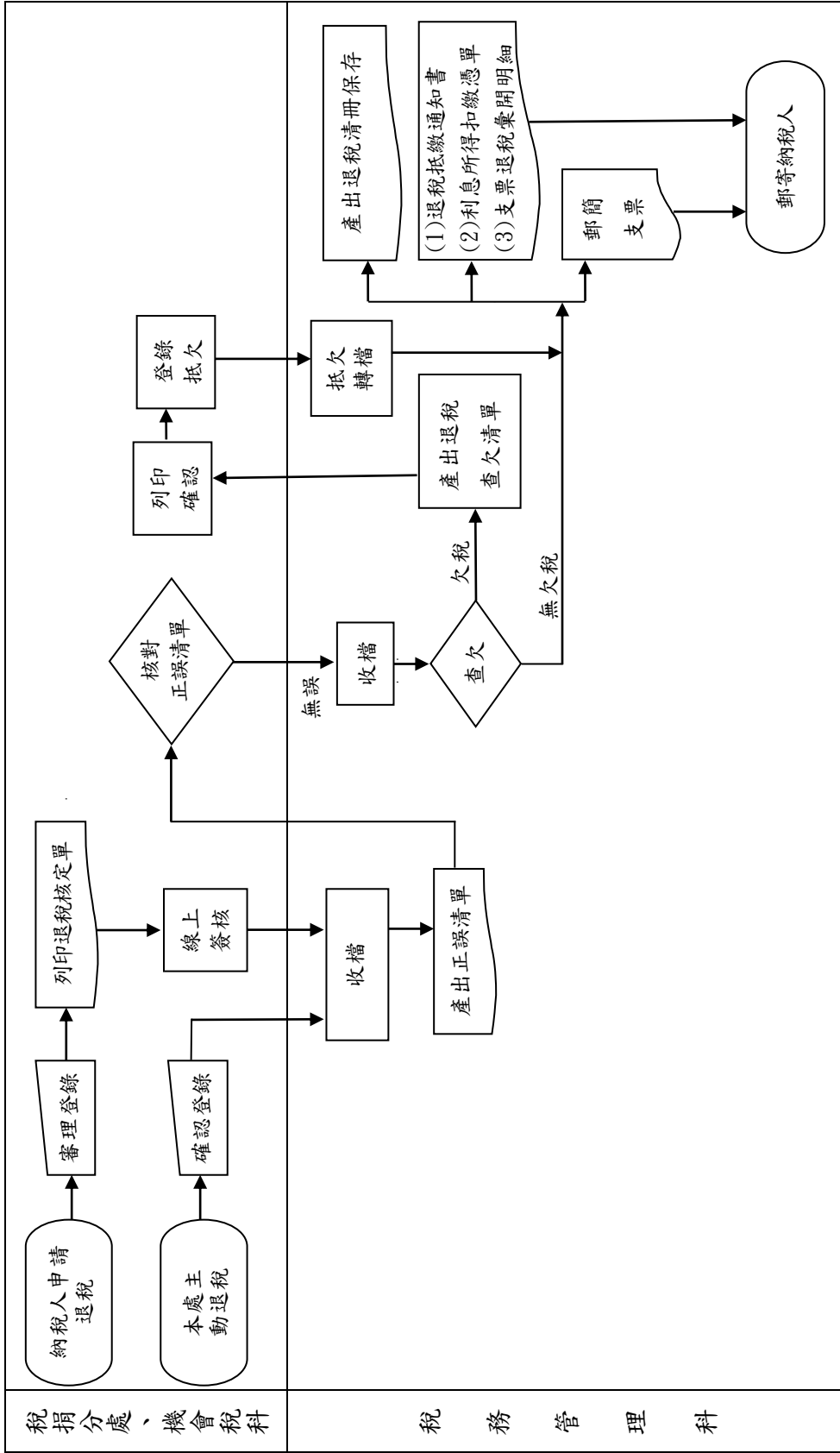
肆、行政組織

IV . Administrative Organization

一、沿革

民國 34 年全省實施統一稽徵制度，臺北市設第一、第二稅務稽徵所管轄本市稅捐稽徵業務，民國 36 年 1 月合併成立臺北市稅捐稽徵處，下設 6 課及城中、中山、延平、萬華、古亭、松山等分處，掌理國、省、地方稅捐稽徵事宜，在系統上隸屬於臺北市政府而受臺灣省政府財政廳指揮監督。

民國 56 年 7 月臺北市改制為直轄市，財政部同時成立臺北市國稅局（102 年更名為財政部臺北國稅局）負責國稅之徵收，本處負責直轄市稅捐稽徵，並同時增設建成分處。民國 57 年 7 月，將市郊景美、木柵、南港、內湖及陽明山管理局之士林、北投等 6 鄉鎮正式劃入為臺北市管轄，除士林、北投另成立為陽明山管理局稅捐稽徵處外，景美、木柵 2 區成立景美分處，南港、內湖 2 區成立南港分處，隸屬於本處。民國 60 年 7 月，因大安區發展迅速，為加強便民服務，由古亭分處撥出成立大安分處。民國 63 年 1 月，原陽明山管理局稅捐稽徵處改隸本處，改設為士林分處。民國 75 年 1 月建成分處併入延平分處，士林分處劃出成立北投分處。民國 77 年 6 月增設內湖及大同 2 個分處。

民國 80 年 7 月，配合臺北市行政區調整為 12 區，本處按行政區域及業務情況設置 13 個分處，分別為中正（城中、古亭合併）、中北、中南（中山分出）、北投、萬華、信義（松山分出）、大安、松山、南港、文山（景美更名）、士林、內湖、大同（延平併入）等分處，就近為市民提供最便捷的納稅服務。

民國 88 年營業稅改制為國稅，仍由本處代徵，10 月為落實組織精簡，提升組織效能，實施組織重整並彈性調整各分處內部架構，業務量較大之大安、中南、中北、松山 4 個分處改設 5 個股，業務量較小之北投、內湖、南港、文山 4 個分處改設 3 個股，其餘大同、中正、信義、萬華、士林等 5 分處仍設 4 個股，並將娛樂稅、印花稅稽徵業務改由分處辦理。

民國 92 年 1 月營業稅移撥由財政部臺北市國稅局稽徵。本處負責房屋稅、地價稅、土地增值稅、契稅、使用牌照稅、娛樂稅、印花稅等地方稅及工程受益費之稽徵。同時重新訂定組織架構，將總處調整為 5 科 5 室，分處仍維持不變，除大安分處設置 4 個股外，其餘分處設置 3 個股。為因應業務需要增設第 2 位副處長職位，於 94 年 1 月正式派任。

民國 95 年 1 月為擴增服務據點，使用牌照稅業務比照其他稅目，將稽徵作業之執行改由分處辦理，人員配合移撥分處。松山分處因牌照稅業務量及員額配置

較多，專設 1 股辦理該項業務，改置為 4 個股，至民國 100 年 9 月為配合使用牌照稅稽徵業務回歸機會稅科管理，復調整為 3 個股。民國 104 年士林分處因業務量及員額配置增加，改置 4 個股。民國 105 年 12 月 12 日配合南門市場改建工程，中正分處遷移至總處。

臺北市政府於民國 102 年辦理本處人員評鑑作業，為應本市 12 個行政區及配合 108 年「使用牌照稅資料整理及登錄作業採購案」委外業務收回自辦，本處進行組織員額調整，自民國 108 年 1 月 2 日起中南及中北分處合併，於中北分處位址改設中山分處，置 4 個股；文山分處及內湖分處因業務量增加，改置 4 個股。

臺北市稅捐稽徵處暨所屬各分處稽徵區域圖

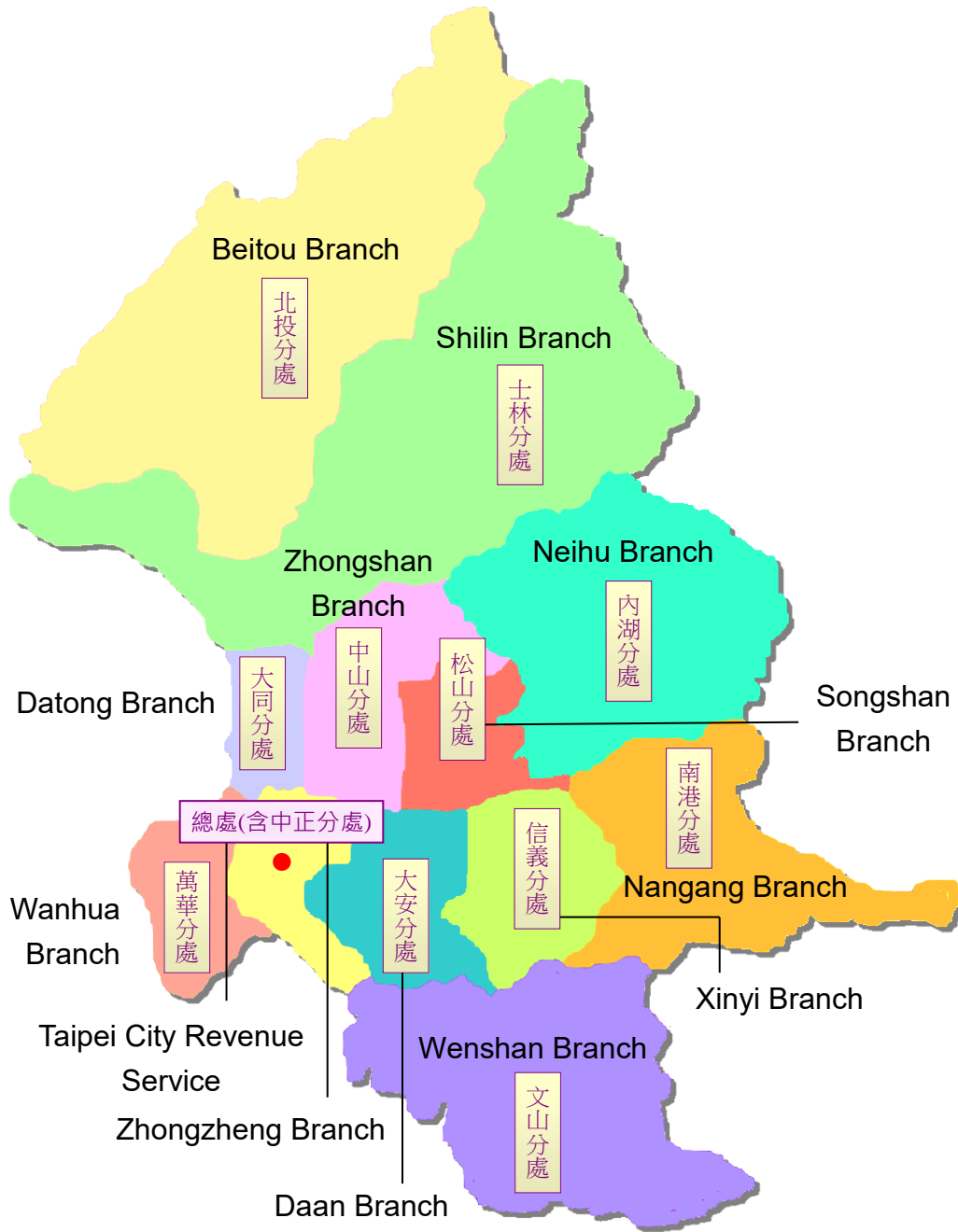

二、組織

本處組織：

依據臺北市政府 93 年 7 月 30 日府法三字第 09312725300 號令核定「臺北市稅捐稽徵處組織規程」，本處隸屬於臺北市政府財政局，置處長 1 人，綜理處務，並置副處長 2 人襄理處務，下設 5 科 5 室及 12 個分處掌理各項地方稅捐稽徵業務。(詳表 4-1)

表 4-1 組織概況

中華民國110年12月底

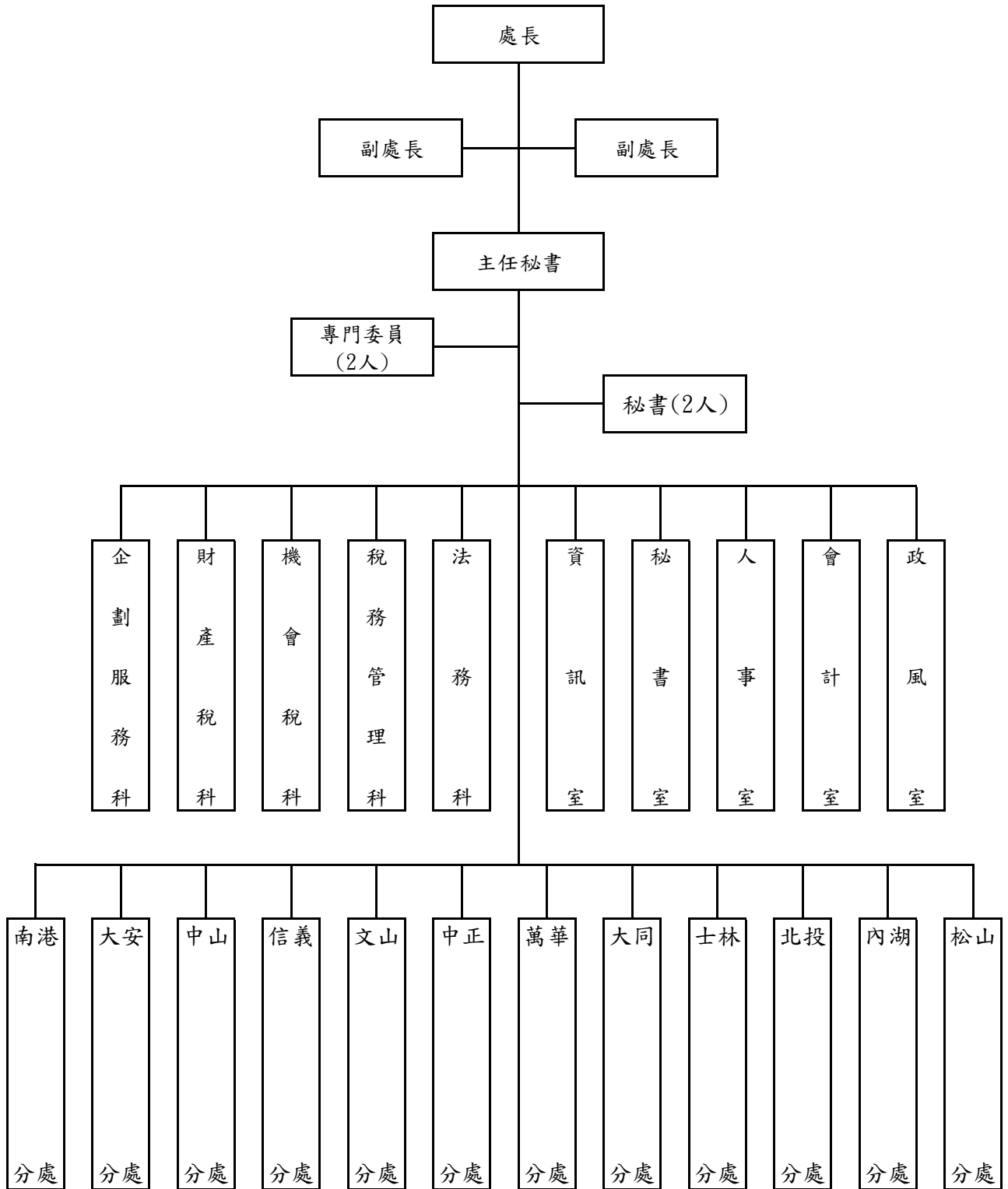

資料來源：根據本處人事室提供資料分析。

Table 4-1 Organization of Headquarter and Branches

End of 2021



表 4-2 現有員額配置

單位：人

年底 End of Year		合計 Total	處長 Director	副處長 Deputy Director	主任秘書 Chief Secretary	專門委員 Senior Specialist
一、預算員額(不含職工、駐衛警察及臨時人員)						
民國101年底	End of 2012	785	1	2	1	2
民國102年底	End of 2013	785	1	2	1	1
民國103年底	End of 2014	785	1	2	1	1
民國104年底	End of 2015	785	1	2	1	1
民國105年底	End of 2016	785	1	2	1	1
民國106年底	End of 2017	785	1	2	1	2
民國107年底	End of 2018	785	1	2	1	2
民國108年底	End of 2019	784	1	2	1	2
民國109年底	End of 2020	784	1	2	1	2
民國110年底	End of 2021	784	1	2	1	2
二、現有員額						
民國101年底	End of 2012	733	1	2	1	1
民國102年底	End of 2013	743	1	2	1	1
民國103年底	End of 2014	750	1	2	1	1
民國104年底	End of 2015	732	1	2	1	1
民國105年底	End of 2016	740	1	2	1	2
民國106年底	End of 2017	731	1	2	1	2
民國107年底	End of 2018	724	1	2	1	1
民國108年底	End of 2019	725	1	2	1	2
民國109年底	End of 2020	730	1	2	1	2
民國110年底	End of 2021	692	1	2	1	2
處本部	Director Office	9	1	2	1	2
企劃服務科	Construction Planning & Service Section	14	-	-	-	-
財產稅科	Property Tax Section	22	-	-	-	-
機會稅科	Opportunity Tax Section	20	-	-	-	-
稅務管理科	Enforcement and Refund Section	22	-	-	-	-
法務科	Legal Affairs Section	14	-	-	-	-
資訊室	Information Management Section	23	-	-	-	-
秘書室	Secretariat Office	31	-	-	-	-
會計室	Accounting Office	18	-	-	-	-
人事室	Personnel Office	15	-	-	-	-
政風室	Civil Service Ethics Office	8	-	-	-	-
松山分處	Songshan Branch	36	-	-	-	-
內湖分處	Neihu Branch	41	-	-	-	-
北投分處	Beitou Branch	43	-	-	-	-
士林分處	Shilin Branch	50	-	-	-	-
大同分處	Datong Branch	32	-	-	-	-
萬華分處	Wanhua Branch	38	-	-	-	-
中正分處	Zhongzheng Branch	35	-	-	-	-
文山分處	Wenshan Branch	38	-	-	-	-
信義分處	Xinyi Branch	39	-	-	-	-
中山分處	Zhongshan Branch	59	-	-	-	-
大安分處	Daan Branch	53	-	-	-	-
南港分處	Nangang Branch	32	-	-	-	-

資料來源：根據本處人事室提供資料編製。

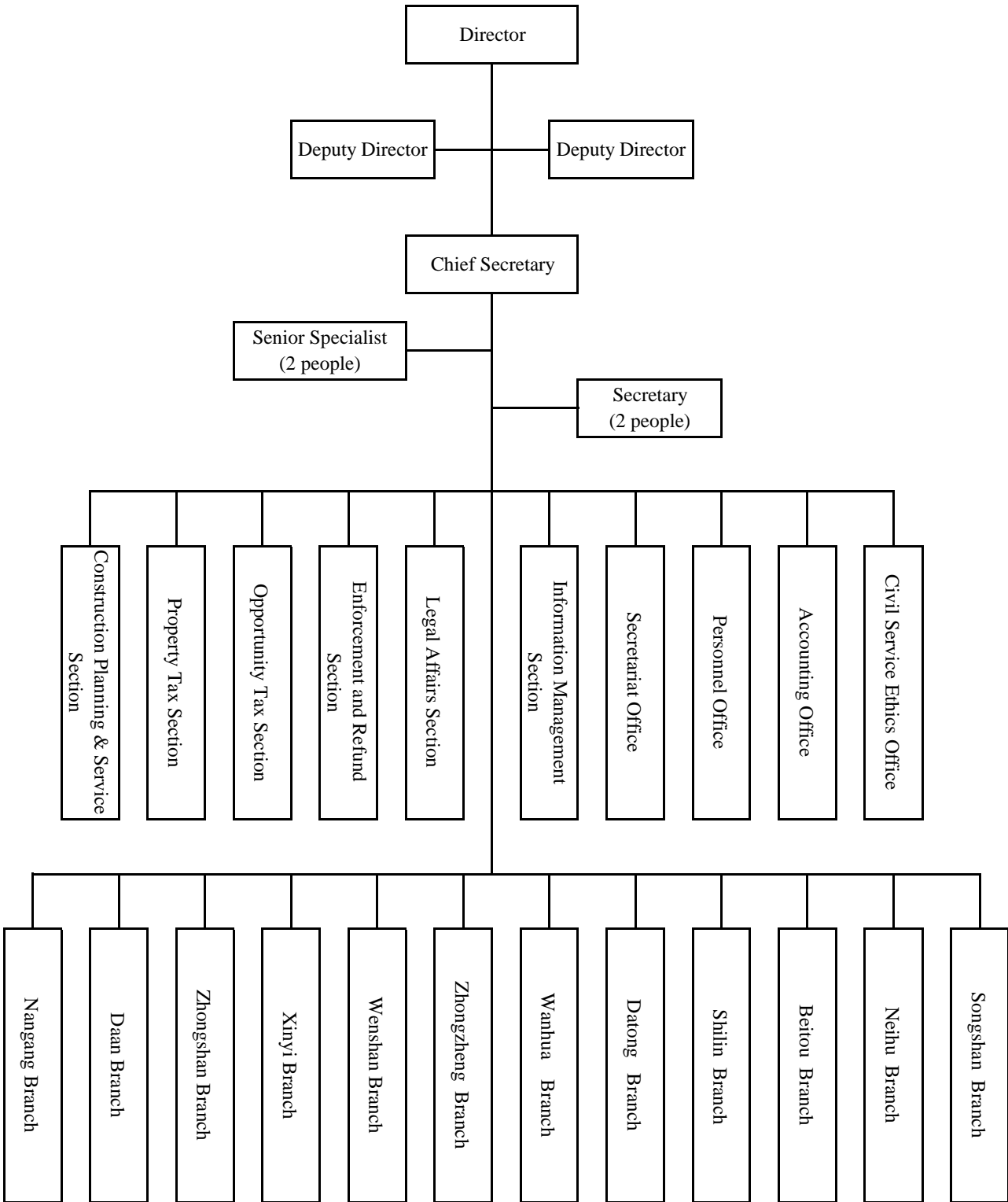
Table 4-2 Allocation of the Personnel

							Unit : Person
科長	分處主任	主任	秘書	督導	審核員	專員	
Section Chief	Manager, Branch	Chief	Secretary	Inspector	Revenue Assessor	Specialist	
1. Estimated Amount							
5	13	5	1	3	18	3	
5	13	5	3	2	18	3	
5	13	5	3	2	18	3	
5	13	5	3	1	19	3	
5	13	5	3	1	19	3	
5	13	5	2	1	19	3	
5	13	5	2	1	19	3	
5	12	5	2	1	19	3	
5	12	5	2	1	19	3	
5	12	5	2	1	19	3	
2. Actual Amount							
5	12	5	3	2	18	3	
5	13	4	3	2	18	3	
5	13	5	3	1	19	3	
5	13	5	3	1	19	3	
5	13	5	2	1	19	3	
5	13	5	2	1	19	3	
5	13	5	2	1	19	3	
5	12	5	2	1	19	3	
5	12	5	2	1	18	3	
5	12	5	2	1	19	3	
-	-	-	2	-	-	-	
1	-	-	-	-	1	-	
1	-	-	-	-	2	-	
1	-	-	-	-	1	-	
1	-	-	-	1	-	-	
1	-	-	-	-	1	-	
-	-	1	-	-	-	-	
-	-	1	-	-	-	-	1
-	-	1	-	-	-	-	1
-	-	1	-	-	-	-	1
-	-	1	-	-	-	-	1
-	1	-	-	-	1	-	-
-	1	-	-	-	1	-	-
-	1	-	-	-	1	-	-
-	1	-	-	-	1	-	-
-	1	-	-	-	1	-	-
-	1	-	-	-	1	-	-
-	1	-	-	-	2	-	-
-	1	-	-	-	2	-	-
-	1	-	-	-	1	-	-

表 4-2 現有員額配置 (續1完)

單位：人

年底 End of Year	股長 Subsection Chief	分析師 System Analyst	設計師 System Designer	管理師 System Coordinator	助理設計師 Assistant Systems Designer
一、預算員額(不含職工、駐衛警察及臨時人員)					
民國101年底 End of 2012	70	2	14	4	6
民國102年底 End of 2013	70	2	14	4	5
民國103年底 End of 2014	70	2	14	4	5
民國104年底 End of 2015	70	2	14	4	5
民國105年底 End of 2016	70	2	14	4	5
民國106年底 End of 2017	70	2	14	4	4
民國107年底 End of 2018	70	2	14	4	4
民國108年底 End of 2019	70	2	14	4	4
民國109年底 End of 2020	70	2	14	4	4
民國110年底 End of 2021	70	2	14	4	4
二、現有員額					
民國101年底 End of 2012	70	2	13	4	5
民國102年底 End of 2013	69	1	13	4	5
民國103年底 End of 2014	69	2	13	4	4
民國104年底 End of 2015	70	2	13	4	4
民國105年底 End of 2016	70	2	13	4	3
民國106年底 End of 2017	69	2	14	4	2
民國107年底 End of 2018	70	2	11	4	4
民國108年底 End of 2019	70	2	13	4	4
民國109年底 End of 2020	70	2	13	4	4
民國110年底 End of 2021	70	2	11	3	3
處本部 Director Office	-	-	-	-	-
企劃服務科 Construction Planning & Service Section	3	-	-	-	-
財產稅科 Property Tax Section	3	-	-	-	-
機會稅科 Opportunity Tax Section	2	-	-	-	-
稅務管理科 Enforcement and Refund Section	3	-	-	-	-
法務科 Legal Affairs Section	2	-	-	-	-
資訊室 Information Management Section	3	2	11	3	3
秘書室 Secretariat Office	4	-	-	-	-
會計室 Accounting Office	4	-	-	-	-
人事室 Personnel Office	3	-	-	-	-
政風室 Civil Service Ethics Office	2	-	-	-	-
松山分處 Songsshan Branch	3	-	-	-	-
內湖分處 Neihu Branch	4	-	-	-	-
北投分處 Beitou Branch	3	-	-	-	-
士林分處 Shilin Branch	4	-	-	-	-
大同分處 Datong Branch	3	-	-	-	-
萬華分處 Wanhua Branch	3	-	-	-	-
中正分處 Zhongzheng Branch	3	-	-	-	-
文山分處 Wenshan Branch	4	-	-	-	-
信義分處 Xinyi Branch	3	-	-	-	-
中山分處 Zhongshan Branch	4	-	-	-	-
大安分處 Daan Branch	4	-	-	-	-
南港分處 Nangang Branch	3	-	-	-	-

資料來源：根據本處人事室提供資料編製。

Table 4-2 Allocation of the Personnel (Cont.1 End)

							Unit : Person
助理管理師 Assistant Systems Coordinator	稅務員 Revenue Officer	助理稅務員 Revenue Assistant	科員 Officer	助理員 Assistant	辦事員 Clerk	書記 Associate Clerk	
1. Estimated Amount							
1	344	163	28	2	20	85	
1	344	163	28	2	20	85	
1	344	163	28	2	20	85	
1	344	163	28	2	20	85	
1	345	164	28	2	20	83	
1	346	165	28	2	20	82	
1	346	165	28	2	20	83	
1	346	165	28	2	20	84	
1	346	165	28	2	20	85	
1	346	165	28	2	20	85	
2. Actual Amount							
1	314	154	27	2	20	68	
1	315	157	28	1	20	76	
1	328	151	27	1	22	74	
1	318	146	28	2	19	71	
1	327	145	26	2	20	73	
1	323	144	27	2	20	69	
1	320	142	27	2	19	69	
1	319	149	28	2	19	61	
-	317	143	27	2	20	76	
-	290	138	25	2	20	75	
-	-	1	-	-	-	-	
-	7	1	-	-	-	1	
-	14	1	-	-	-	1	
-	5	6	-	-	1	4	
-	7	6	-	-	-	4	
-	8	1	-	-	-	1	
-	-	-	-	-	-	-	
-	-	-	5	-	5	15	
-	-	-	10	-	1	1	
-	-	-	7	2	-	1	
-	-	-	3	-	1	1	
-	16	10	-	-	1	4	
-	22	7	-	-	1	5	
-	22	10	-	-	1	5	
-	27	13	-	-	1	3	
-	15	7	-	-	1	4	
-	18	9	-	-	1	5	
-	17	9	-	-	1	3	
-	21	9	-	-	1	1	
-	18	10	-	-	1	5	
-	34	14	-	-	1	3	
-	26	15	-	-	1	4	
-	13	9	-	-	1	4	

表 4-3 現有人員人事資料統計

單位：人

年底及人事種類別 End of Year & Classification		合計 Total	官等 Official Rank			雇員 Contract Employee
			簡任 第10-14職等 Highest Appointee (10-14 Grade)	薦任 第6-9職等 Higher Appointee (6-9 Grade)	委任 第1-5職等 Appointee (1-5 Grade)	
民國101年底	End of 2012	733	3	361	366	3
民國102年底	End of 2013	743	3	370	367	3
民國103年底	End of 2014	750	3	395	349	3
民國104年底	End of 2015	732	3	389	337	3
民國105年底	End of 2016	740	3	403	332	2
民國106年底	End of 2017	731	3	418	308	2
民國107年底	End of 2018	724	3	410	310	1
民國108年底	End of 2019	725	3	421	301	-
民國109年底	End of 2020	730	3	414	313	-
民國110年底	End of 2021	692	3	413	276	-
		一、性 別 Sex				
男	Male	154	1	86	67	-
女	Female	538	2	327	209	-
		二、年 齡 Age				
19歲以下	Under 19 Years Old	-	-	-	-	-
20-24歲	20-24 Years Old	17	-	11	6	-
25-29歲	25-29 Years Old	80	-	39	41	-
30-34歲	30-34 Years Old	94	-	43	51	-
35-39歲	35-39 Years Old	94	-	51	43	-
40-44歲	40-44 Years Old	87	-	49	38	-
45-49歲	45-49 Years Old	81	-	49	32	-
50-54歲	50-54 Years Old	119	1	89	29	-
55-59歲	55-59 Years Old	78	1	56	21	-
60-64歲	60-64 Years Old	38	-	25	13	-
65歲以上	Above 65 Years Old	4	1	1	2	-

資料來源：根據本處人事室(WEBHR系統)提供資料編製。

說明：「中等學校」包括國中、高中及高職，「其他考試」包括初等考試及升等考試。

Table 4-3 Personnel Statistics

		Unit : Person				
人事種類別 Classification		合計 Total	官等 Official Rank			雇員 Contract Employee
			簡任 第10-14職等 Highest Appointee (10-14 Grade)	薦任 第6-9職等 Higher Appointee (6-9 Grade)	委任 第1-5職等 Appointee (1-5 Grade)	
三、人員區分 Division of Responsibilities						
稅務人員	Revenue Officer	556	3	359	194	-
行政人員	General Officer	72	-	10	62	-
資訊人員	Information Officer	23	-	14	9	-
主計人員	Accounting Officer	18	-	15	3	-
人事人員	Personnel Officer	15	-	10	5	-
政風人員	Civil Service Ethics Officer	8	-	5	3	-
四、學歷 Education						
研究所以上	Master	109	2	85	22	-
大學	Colleger	469	1	268	200	-
專科	Junior Colleger	93	-	56	37	-
中等學校	High School	20	-	4	16	-
其他	Others	1	-	-	1	-
五、考試 Examination						
高等考試	Advanced Exam	187	1	186	-	-
普通考試	Ordinary Exam	61	-	-	61	-
特種考試	Special Exam	250	-	100	150	-
其他考試	Other Civil Service Exam	193	2	127	64	-
依其他法令進用	By other Laws	1	-	-	1	-
六、年資 Seniority						
5年以下	Less than 5 Years	209	-	94	115	-
6-9年	6-9 Years	114	-	56	58	-
10-14年	10-14 Years	98	-	54	44	-
15-19年	15-19 Years	60	-	40	20	-
20-24年	20-24 Years	62	-	45	17	-
25-29年	25-29 Years	103	1	86	16	-
30年以上	More than 30 Years	46	2	38	6	-

表 4-4 歲出預決算數①②

單位：新臺幣元

會計年度及科目別 Fiscal Year & Classification		合計 Total					預算 金額 Amount
		預算 Budget		決算 Final Account		決算 占預算% FA/B Rate	
		金額 Amount	%	金額 Amount	%		
民國101年度	FY 2012	926,239,026	100.00	898,931,066	100.00	97.05	-
民國102年度	FY 2013	937,691,092	100.00	916,073,419	100.00	97.69	2,340,900
民國103年度	FY 2014	928,468,874	100.00	918,028,505	100.00	98.88	-
民國104年度	FY 2015	974,283,556	100.00	949,010,297	100.00	97.41	-
民國105年度	FY 2016	924,717,371	100.00	910,775,252	100.00	98.49	-
民國106年度	FY 2017	923,301,505	100.00	909,997,555	100.00	98.56	-
民國107年度	FY 2018	1,005,175,664	100.00	992,359,020	100.00	98.72	19,959,000
民國108年度	FY 2019	983,278,000	100.00	955,037,035	100.00	97.13	7,900,000
民國109年度	FY 2020	1,054,941,000	100.00	1,029,892,526	100.00	97.63	3,852,000
民國110年度	FY 2021	955,769,473	100.00	943,315,982	100.00	98.70	-
一般行政		824,469,000	86.26	818,334,516	86.75	99.26	-
行政管理		824,469,000	86.26	818,334,516	86.75	99.26	-
稅捐稽徵業務		112,070,473	11.73	106,181,736	11.26	94.75	-
財產稅稽徵		24,656,000	2.58	24,286,815	2.57	98.50	-
機會稅稽徵		20,927,473	2.19	19,029,359	2.02	90.93	-
稅務管理		26,407,000	2.76	23,644,924	2.51	89.54	-
違章及行政救濟		560,000	0.06	206,292	0.02	36.84	-
電子資料處理		39,520,000	4.13	39,014,346	4.14	98.72	-
一般建築及設備		19,230,000	2.01	18,799,730	1.99	97.76	-
土地購置		100,000	0.01	-	-	-	-
營建工程		10,877,000	1.14	10,587,915	1.12	97.34	-
交通及運輸設備		-	-	-	-	--	-
其他設備		8,253,000	0.86	8,211,815	0.87	99.50	-

資料來源：依據本處會計室決算書編製。

說明：①本表不包括統籌科目。

Table 4-4 The Budget and Final Accounts of Annual Expenditure

Unit : N.T.\$

中央負擔 Central Government Subsidy				直轄市/市/縣負擔 Municipality/City/County Government Burden				
Budget	決算 Final Account		決算 占預算% FA/B Rate	預算 Budget		決算 Final Account		決算 占預算% FA/B Rate
%	金額 Amount	%		金額 Amount	%	金額 Amount	%	
-	-	-	-	926,239,026	100.00	898,931,066	100.00	97.05
100.00	2,024,754	100.00	86.49	935,350,192	100.00	914,048,665	100.00	97.72
-	-	-	-	928,468,874	100.00	918,028,505	100.00	98.88
-	-	-	-	974,283,556	100.00	949,010,297	100.00	97.41
-	-	-	-	924,717,371	100.00	910,775,252	100.00	98.49
-	-	-	-	923,301,505	100.00	909,997,555	100.00	98.56
100.00	19,951,318	100.00	99.96	985,216,664	100.00	972,407,702	100.00	98.70
100.00	7,900,000	100.00	100.00	975,378,000	100.00	947,137,035	100.00	97.10
100.00	3,851,500	100.00	99.99	1,051,089,000	100.00	1,026,041,026	100.00	97.62
-	-	-	--	955,769,473	100.00	943,315,982	100.00	98.70
-	-	-	--	824,469,000	86.26	818,334,516	86.75	99.26
-	-	-	--	824,469,000	86.26	818,334,516	86.75	99.26
-	-	-	--	112,070,473	11.73	106,181,736	11.26	94.75
-	-	-	--	24,656,000	2.58	24,286,815	2.57	98.50
-	-	-	--	20,927,473	2.19	19,029,359	2.02	90.93
-	-	-	--	26,407,000	2.76	23,644,924	2.51	89.54
-	-	-	--	560,000	0.06	206,292	0.02	36.84
-	-	-	--	39,520,000	4.13	39,014,346	4.14	98.72
-	-	-	--	19,230,000	2.01	18,799,730	1.99	97.76
-	-	-	--	100,000	0.01	-	-	-
-	-	-	--	10,877,000	1.14	10,587,915	1.12	97.34
-	-	-	--	-	-	-	-	--
-	-	-	--	8,253,000	0.86	8,211,815	0.87	99.50

說 明：◎110年度決算數尚未經審計部臺北市審計處審定。

中華民國 110 年度
臺北市稅捐統計年報

出版機關：臺北市稅捐稽徵處

發行人：倪永祖

編輯：臺北市稅捐稽徵處會計室

地址：臺北市中正區北平東路 7 之 2 號

電話：(02)23949211 分機 341

網址：www.tpctax.gov.taipei

創刊日期：中華民國 42 年 2 月

出版日期：中華民國 111 年 5 月

出刊頻率：年刊

本刊登載於本處網站

依法納稅是義務

合法節稅是權利

主動退稅是責任

