

C型鋪面鋪設平面圖

A1 (1:20) A3 (1:40) Unit:cm

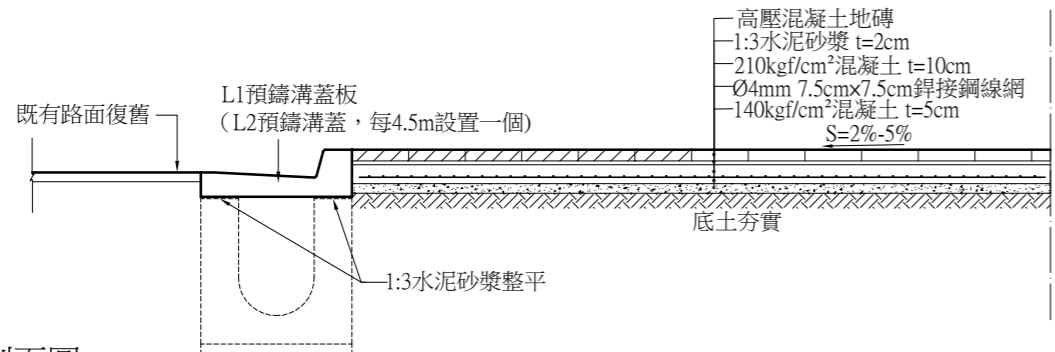
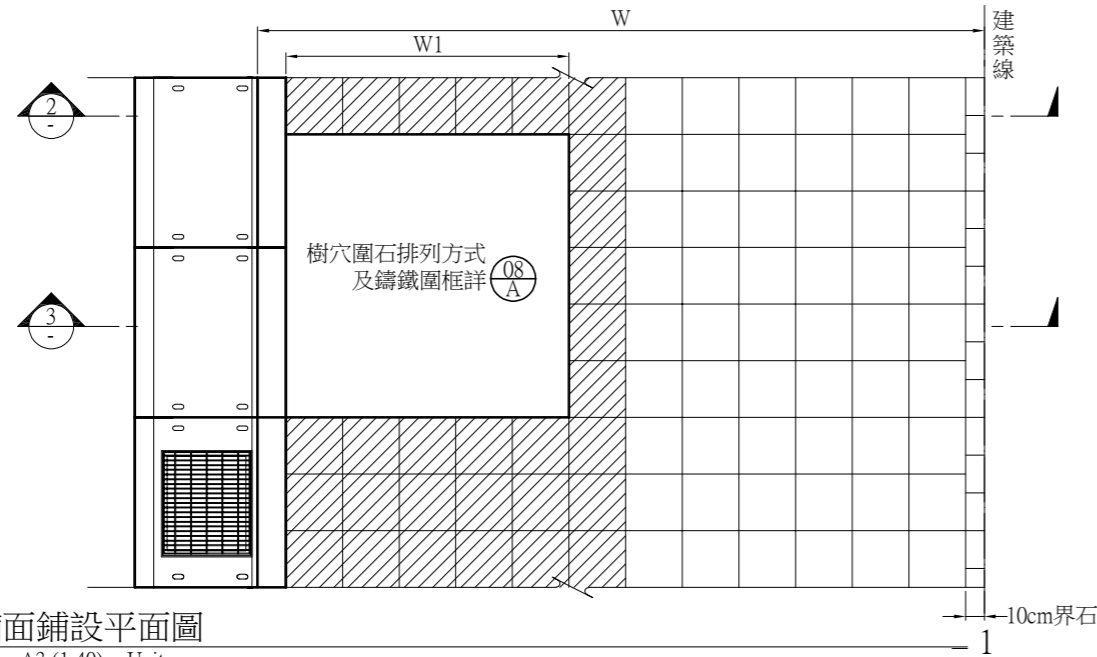

剖面圖

A1 (1:20) A3 (1:40) Unit:cm

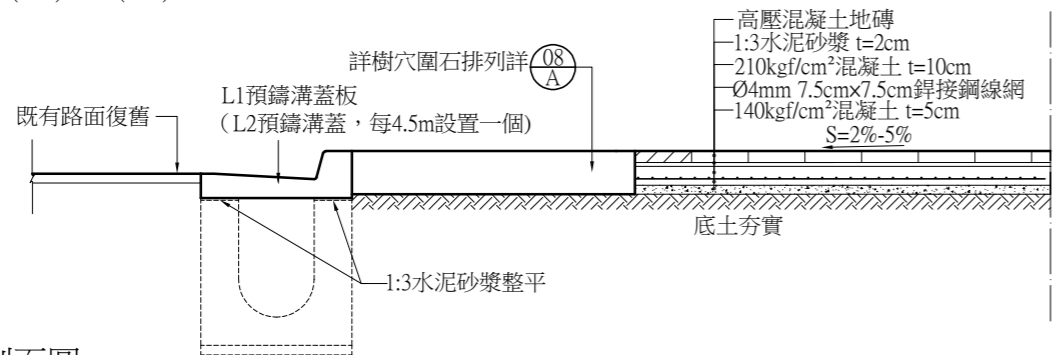

剖面圖

A1 (1:20) A3 (1:40) Unit:cm

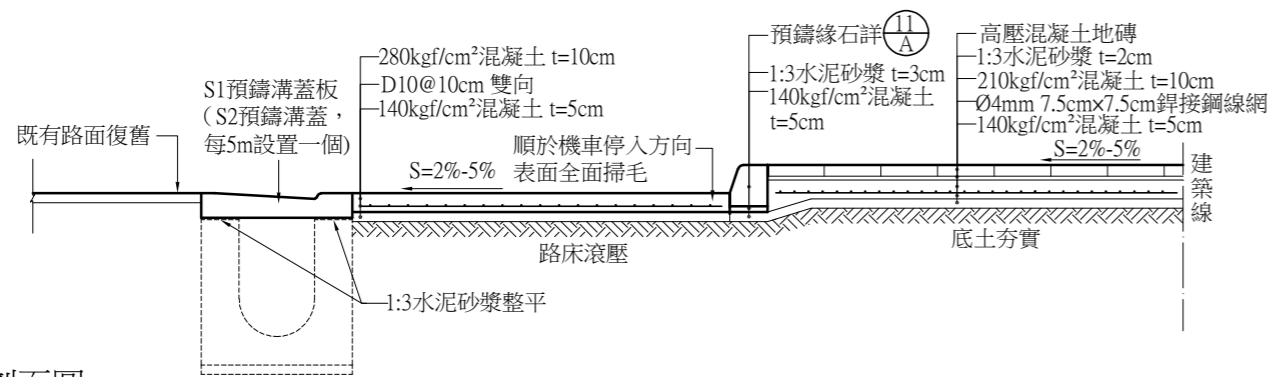

剖面圖

A1 (1:20) A3 (1:40) Unit:cm

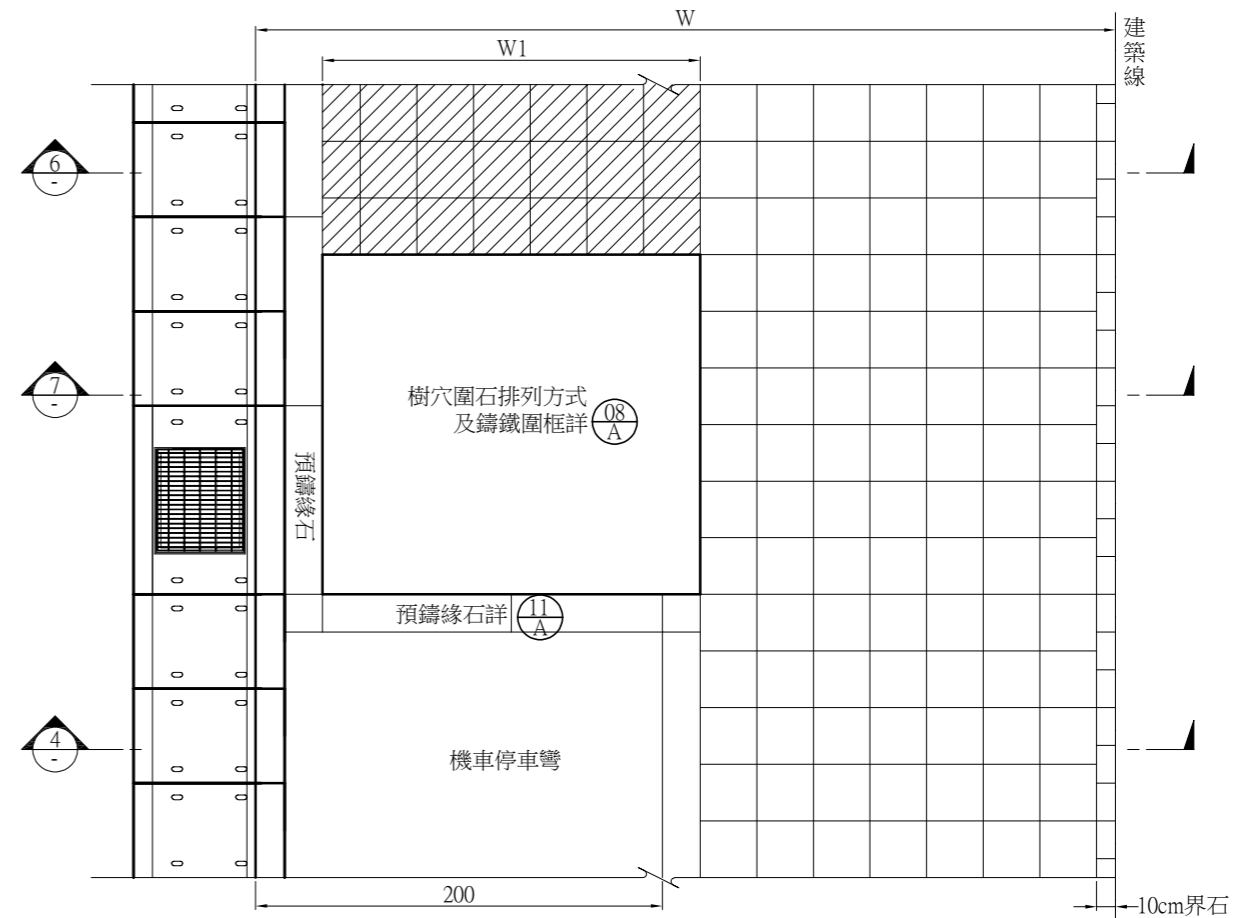

D型鋪面鋪設平面圖

A1 (1:20) A3 (1:40) Unit:cm

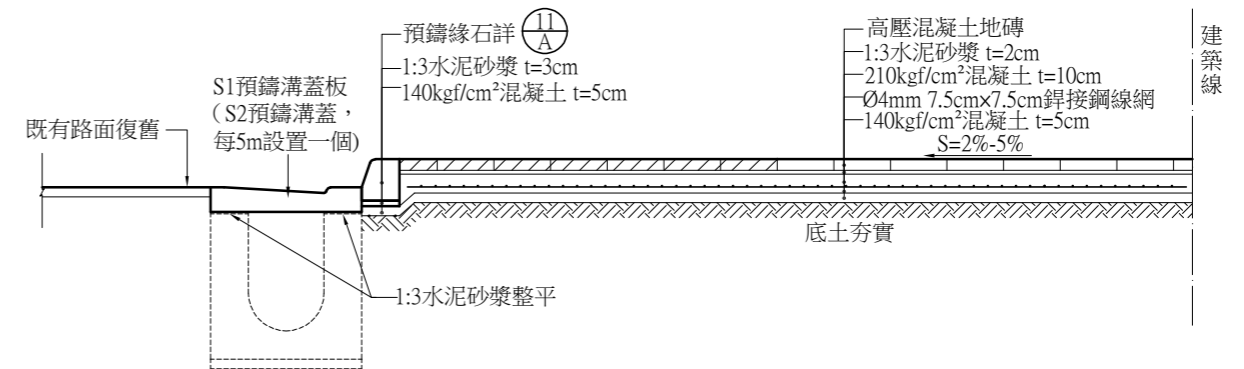

剖面圖

A1 (1:20) A3 (1:40) Unit:cm

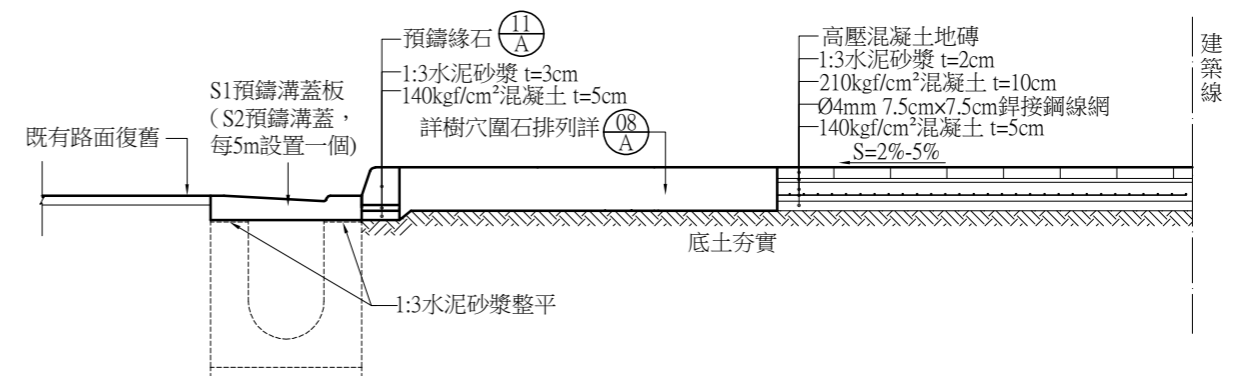

剖面圖

A1 (1:20) A3 (1:40) Unit:cm